

UDI_0073-815-005 Remote control, advanced

How to install the advanced remote-control option

APPLICABLE TO:

Precision i5

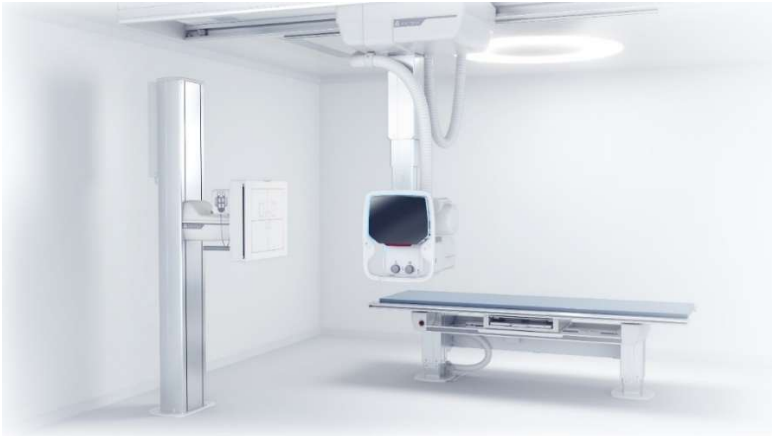

Kit p/n : 0073-815-005



TOOLS NEEDED:



Standard Service tools.

Cable ties

Service laptop.

RS-232 Service cable *p/n*
1100-810-201.

PROTECTIVE MEASURES:

CAUTION!

Printed circuit boards contain electrostatic highly sensitive components requiring particular care in their handling. Ground before making contact and place only on a conductive surface.

CAUTION!

Remaining energy may exist when the equipment is switched off. Always wait at least 15 seconds before working on the system.

ACTION STEPS:

1. Test the system to confirm that it is fully functional.
2. Place the OTC in a good working position where it can be easily accessed. Moving the tube head downwards in Z direction will help to relieve tension from the elastic cable cord and make it easier to remove the ceiling covers.

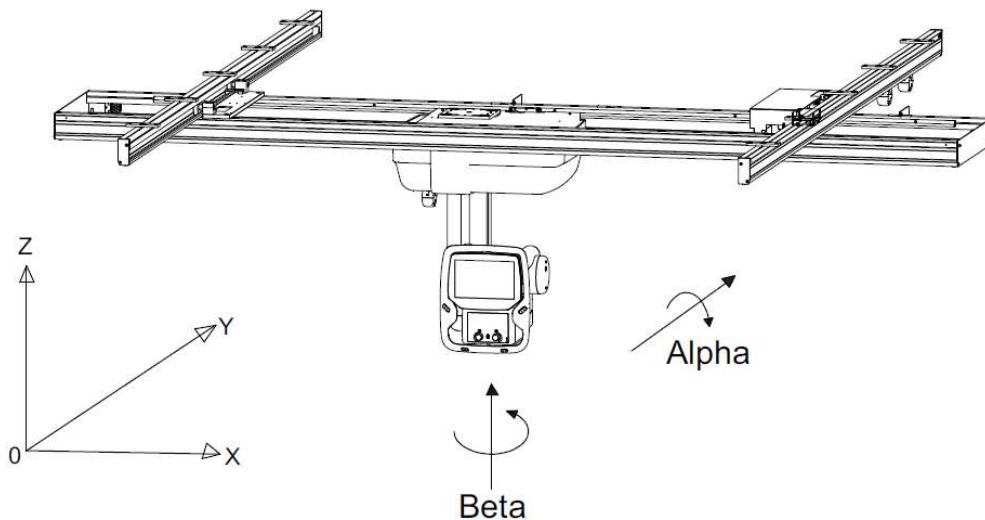

3. Turn the system OFF from the generator mini console.



4. Release and remove the two screws for the larger right-hand cover of the ceiling wagon.



5. Remove the cover.

6. Release and remove the five screws for the smaller left-hand cover of the ceiling wagon.



7. Mark the position of the cable holder.



8. Release and remove the two Torx T20 screws for the cable holder and hang down the cable.



9. Secure the elastic lifting cord and untie the knot. Pull the cord through the cable holder and the hole in the left-hand cover. Secure the elastic lifting cord temporarily with a knot.

10. Remove the cover.



11. Release the screw holding electrical plate 1.1 and fold down the plate on its hinges.
NOTE! Support the electrical plate during this step to prevent it from falling.



12. The receiver for the remote control is mounted on the left side of the ceiling wagon.



13. Release the two screws enough to slide on the receiver bracket, p/n 0073-007-208 from the upgrade kit.

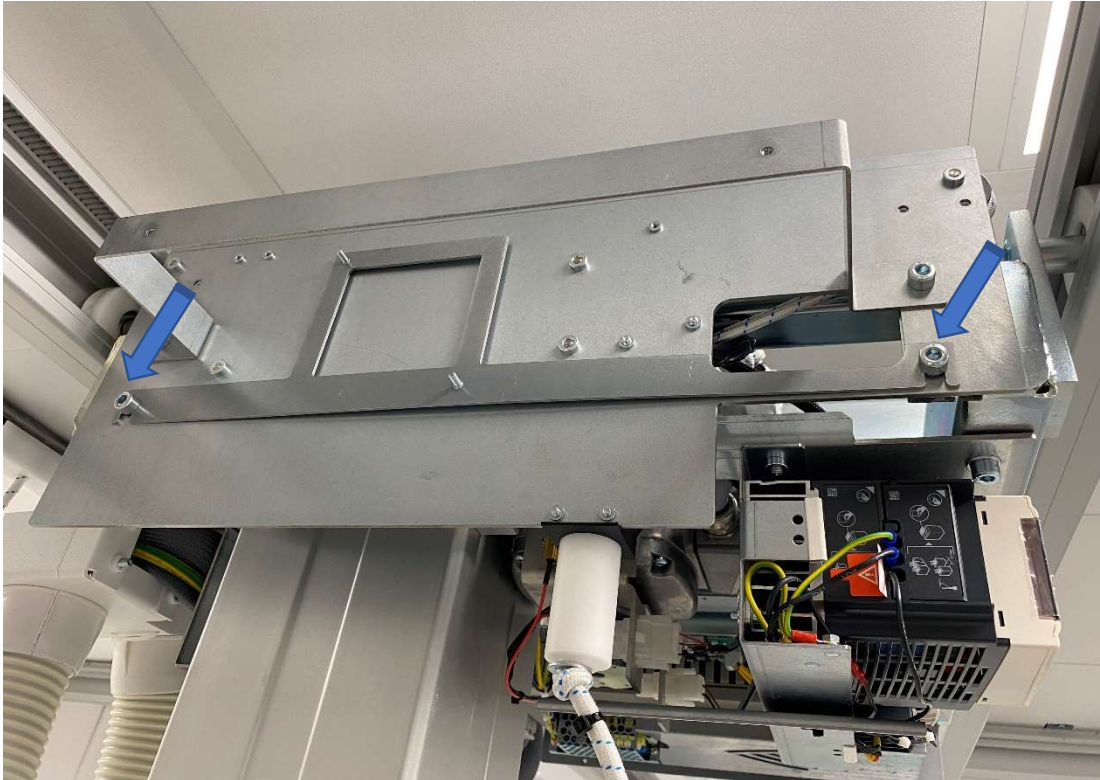

14. Tighten the screws.

15. Position the receiver unit and mount it with washers and nuts from the upgrade kit.



16. Position cable p/n 0073-750-085 from the upgrade kit. It has been pre-wired from factory. See drawing *0072-UBD-112 OTC 2 Remote advanced* for reference.
17. Rout the cable towards electrical plate 1.1 and connect it. See drawing *0072-UBD-112 OTC 2 Remote advanced* for reference.

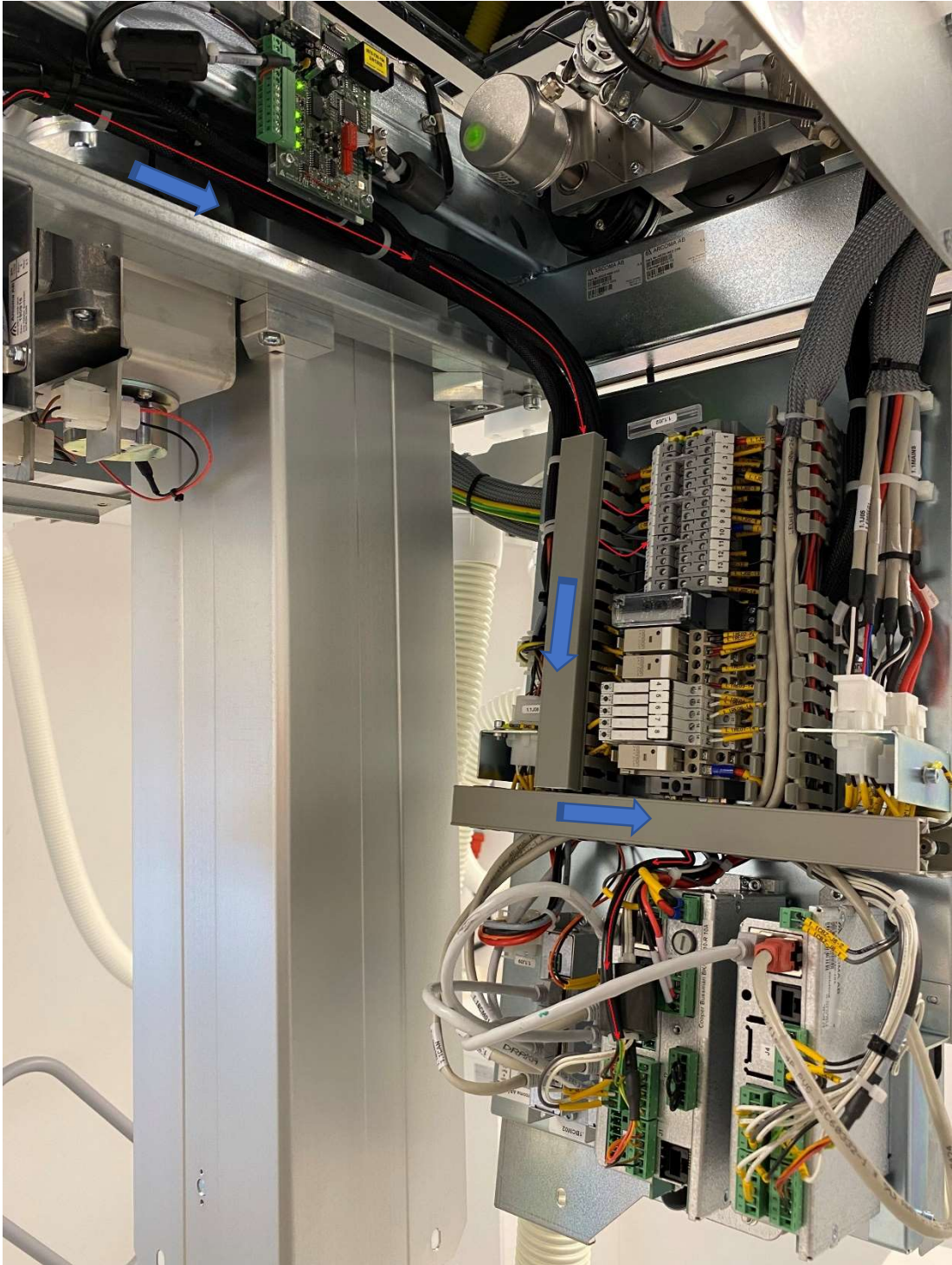

18. The upgrade actions are now done, and the system can be restored.

19. Fold up electrical plate 1.1 on its hinges. Secure the plate with the screw.

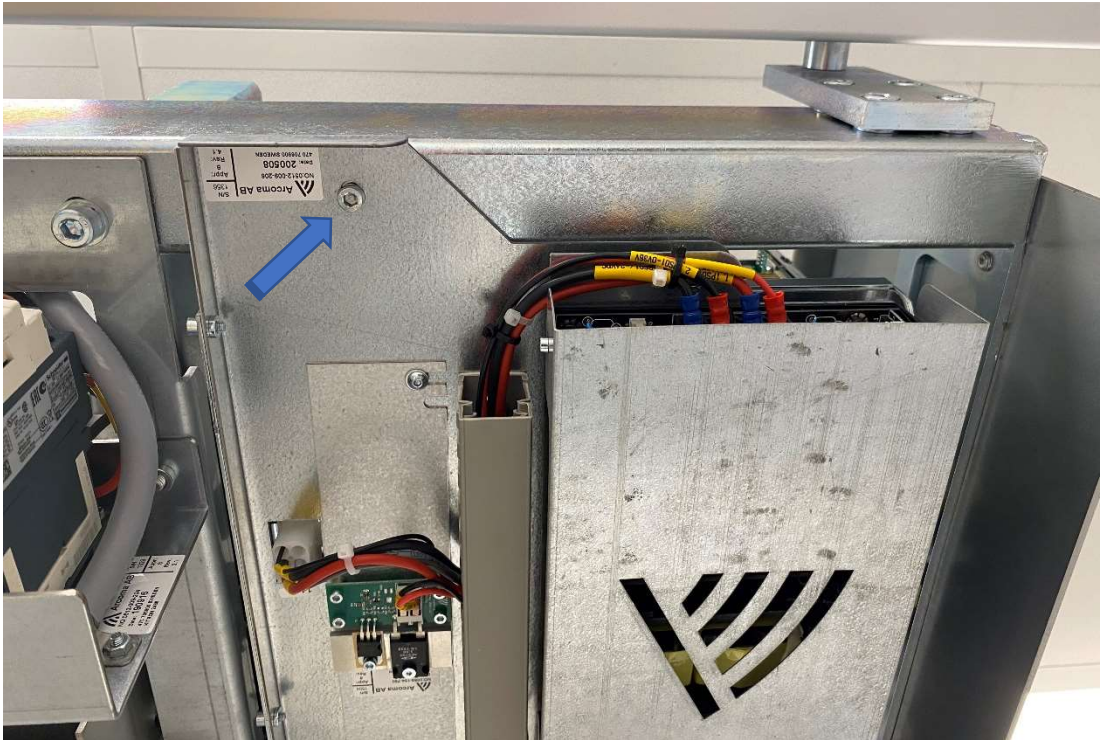

20. Re-mount the left-hand cover of the ceiling wagon using the five screws.



21. Hang the cable back up and reattach the two Torx T20 screws for the cable holder.



22. Re-mount the right-hand cover of the ceiling wagon using the two screws.



23. The remote-control transmitter has been paired with the receiver from factory. Batteries are also inserted. The remote control is ready to use.



24. Turn the system ON from the generator mini console.



25. Confirm that the system runs on a software version where the advanced remote-control option is available.

NOTE! Software version must be at least version 5.7.
Recommended version is 1.1 (5.9) or later.

See software upgrade instructions (UDI) or the tutorial video on our partner portal for more information on how to upgrade software.

26. Test the system and confirm that it works as expected.

Pairing

1. Open the receiver and locate the function buttons on the right side of the box.

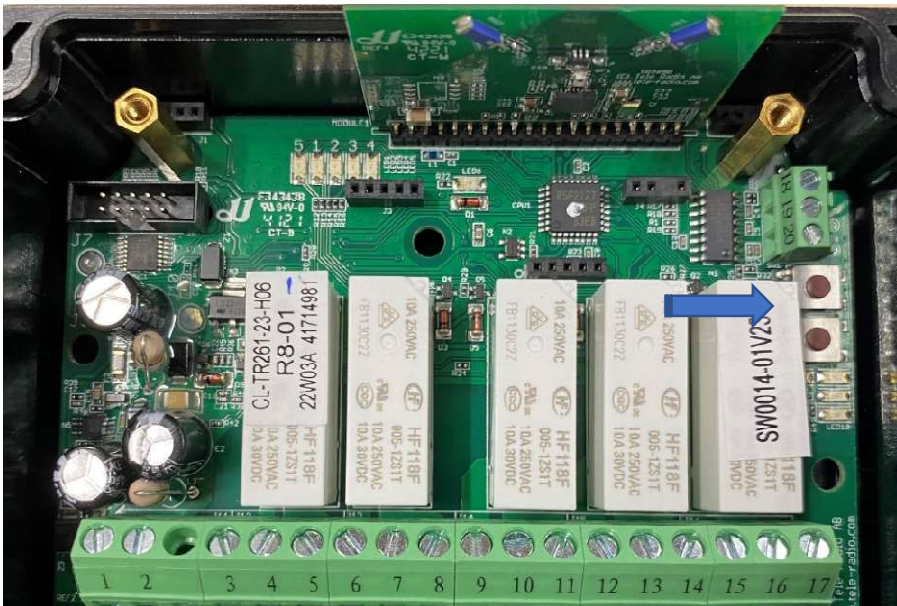

2. Press and release function button F.
LED7 is turned ON.
3. Press and release function button S.
LED's 1-5 turns ON.
4. Before the LED's turn OFF, simultaneously press buttons 3 and 4 and keep them pressed until receiver LED's starts to flash. Tx1 is now paired with the receiver.

5. Repeat step 2-3
6. Before the LED's turn OFF, simultaneously press buttons 10 and 11 and keep them pressed until receiver LED's starts to flash. Tx2 is now paired with the receiver.

Replace batteries.

Battery replacement is recommended during annual maintenance.

Remove the rubber plugs and release the four screws on the transmitters back cover.

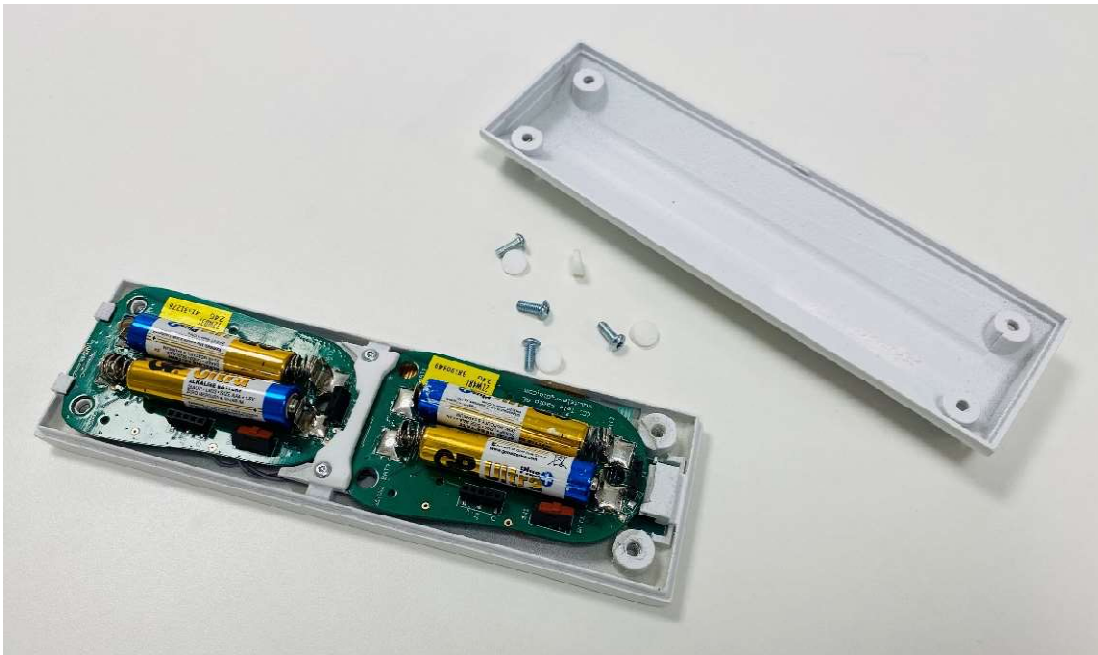

27. Turn both transmitter sections OFF.

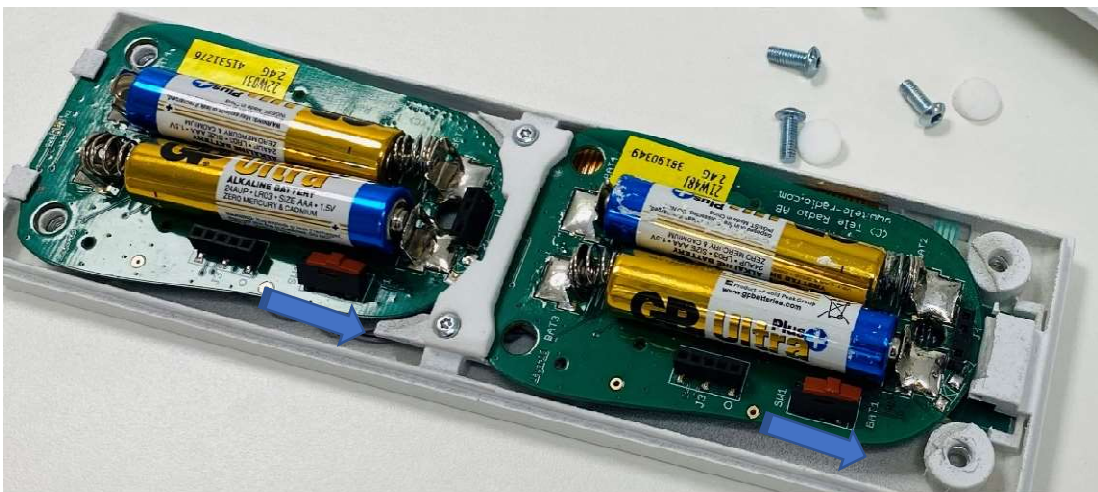

28. Replace the 4 x 1,5V AAA batteries.
29. Turn both transmitter sections back ON.
30. Mount the back cover.

END OF DOCUMENT