

# OMNERA<sup>®</sup> 500A

Auto-Positioning Digital Radiographic System

## Operator's Manual



Technical Publication: 1000-095-071-EN Rev. 2.1

**Canon**

CANON MEDICAL SYSTEMS USA, INC.

### **Disclaimer**

The standard warranty is void if the system has been intentionally modified, or damaged by accident, abuse or misuse. Additionally, this warranty is void if untrained personnel service the OMNERA® 500A equipment.

Lost profits, downtime, goodwill, damage to or replacement of property, and any costs of repairing the OMNERA® 500A resulting from a breach of warranty are not the responsibility of Canon Medical Systems

Specifications are subject to change without notice. Not responsible for typographical errors.

### **Notices**

No part of this publication may be reproduced, transmitted, transcribed, stored in a retrieval system or translated into any language or computer language, in any form or by any means, electronic, mechanical, magnetic, optical, chemical, manual or otherwise, without the prior written permission of Canon Medical Systems

**Note:** Photos and drawings used in this guide may be slightly different from the actual system.



Dispose of electronic equipment in accordance with local, state, and federal regulations.

THIS DOCUMENT CONTAINS PROPRIETARY INFORMATION AND SUCH INFORMATION  
MAY NOT BE DISCLOSED TO OTHERS FOR ANY PURPOSE NOR USED FOR  
MANUFACTURING PURPOSES WITHOUT WRITTEN PERMISSION FROM CANON  
MEDICAL SYSTEMS.

### **Trademarks**

OMNERA® is a registered trademarks of Canon Medical Systems

All third-party brand names, product names, or logos appearing in this manual are the trademarks or registered trademarks of their respective owners.

Canon® is a registered trademark of Canon, Inc. and may also be a registered trademark or a trademark in other countries.

	<b>Rev</b>	<b>Date</b>
New release	1.1	2020-09
<b>1.2 Identification Labels</b> updated Updated <b>6 Cleaning and Disinfection</b> to Added warning from <b>6 Cleaning and Disinfection</b> to <b>2.2 Precautions, Safety</b> Added <b>8 Complying Standards</b> Added AEC Accuracy in table Output Parameter and Loading Factor in <b>9.3 Radiographic Specification</b> Added <b>9.4 Collimator</b> Added <b>9.5 X-ray Tube</b>	2.1	2021-06





<b>1</b>	<b>Introduction .....</b>	<b>1</b>
1.1	Document Information .....	1
1.1.1	<i>System Documentation</i> .....	1
1.1.2	<i>Stylistic Conventions</i> .....	1
1.1.3	<i>Document Producer</i> .....	1
1.1.4	<i>Copyright © 2021 Arcoma Corporation All Rights Reserved.</i> .....	1
1.1.5	<i>Text Emphasis</i> .....	2
1.2	Identification Labels .....	3
1.3	System Description .....	6
1.3.1	<i>General</i> .....	6
1.3.2	<i>Intended Use</i> .....	6
1.3.3	<i>Configuration</i> .....	6
1.3.4	<i>System Overview</i> .....	7
1.3.5	<i>Overhead Tube Crane, Overview</i> .....	8
1.3.6	<i>Table Overview</i> .....	9
1.3.7	<i>Wallstand Overview.</i> .....	10
<b>2</b>	<b>Safety .....</b>	<b>11</b>
2.1	Compliance .....	11
2.2	Precautions, Safety .....	12
2.3	Qualifications of Personnel .....	15
2.3.1	<i>Operating Personnel</i> .....	15
2.3.2	<i>Service Personnel</i> .....	15
2.4	Service and Maintenance .....	16
2.5	Installation and Repair .....	17
2.6	Safety and Warning Symbols .....	18
2.7	Safety and Warning Labels on the Equipment .....	19
2.8	Applied Parts .....	20
2.9	Essential Performance and Basic Safety .....	21
2.10	Emergency Stop .....	22
2.11	Radiation and X-Ray Tube .....	23
2.11.1	<i>Radiation Protection</i> .....	24
2.12	Mechanical Safety .....	29
2.12.1	<i>General</i> .....	29
2.12.2	<i>Overhead Tube Crane</i> .....	30
2.12.3	<i>Cabinet</i> .....	31
2.12.4	<i>Table</i> .....	32
2.12.5	<i>Wallstand</i> .....	38
2.13	Safety Functions .....	40
2.13.1	<i>Table Safety Zone and Overhead Tube Crane</i> .....	40
2.13.2	<i>Wallstand Safety Zone</i> .....	40
2.13.3	<i>Collision Detection</i> .....	40
2.13.4	<i>Dead Man's Grip</i> .....	41
2.14	Electromagnetic Compatibility (EMC) .....	42
<b>3</b>	<b>User Interface .....</b>	<b>45</b>
3.1	Overhead Tube Crane .....	45
3.1.1	<i>Direction of Movement</i> .....	45
3.1.2	<i>Sound Signal</i> .....	45
3.1.3	<i>System Display Overview</i> .....	46
3.2	Automatic Collimator Control .....	47
3.2.1	<i>Automatic Collimator</i> .....	47
3.3	Display User Interface .....	51
3.3.1	<i>Patient Information</i> .....	52
3.3.2	<i>Position Information</i> .....	52

# Contents

---

3.3.3	Adjustment of Generator Parameters (kV, mA, ms, mAs, Density).....	53
3.3.4	Settings.....	54
3.3.5	System Mode.....	61
3.3.6	Hospital method book.....	66
3.3.7	Selection of Technique Mode .....	67
3.3.8	Patient Size .....	69
3.3.9	Collimator Centering.....	70
3.3.10	Servo State Mode .....	71
3.3.11	Grid Status .....	72
3.3.12	Light Indication.....	74
3.4	Exposure .....	75
3.4.1	Exposure Hand Control .....	75
3.4.2	Exposure Index.....	75
3.4.3	Deviation Index.....	75
3.5	Image System .....	76
3.6	Remote Control (option) .....	77
3.7	Servo Button .....	79
3.7.1	External Servo Button Module.....	79
3.7.2	Indication Light.....	79
3.7.3	DAP .....	79
3.8	Table Control elements.....	80
3.8.1	Directions of Movement .....	80
3.8.2	Power Indication .....	80
3.8.3	Foot Control, Table X/Y/Z (option) .....	80
3.8.4	Foot Control, Wireless (option) .....	81
3.8.5	XY Foot Control, Strip Type (Option) .....	82
3.8.6	Table Hand Control .....	83
3.8.7	Moving Table Top.....	84
3.8.8	Vertical Travel Safety (option).....	84
3.8.9	Attach/Remove Accessories .....	85
3.8.10	Motorized Imaging Unit Movement .....	86
3.9	Wallstand Control Elements.....	87
3.9.1	Wallstand Controls.....	87
<b>4</b>	<b>Operating the System.....</b>	<b>91</b>
4.1	Turn On The System .....	91
4.2	Turn Off The System .....	93
4.3	Perform Examination .....	95
4.3.1	Select Patient .....	95
4.3.2	Start Examination.....	96
4.3.3	Position The System .....	97
4.3.4	Adjust Position And Collimator For Chosen Examination And Patient.....	97
4.3.5	Exposure.....	98
4.3.6	Review Image.....	99
4.3.7	Change Work Space .....	100
4.3.8	Basic Exposure Error Handling.....	101
4.4	Movement Short-Cut Zones.....	102
4.4.1	Wallstand Short-Cut Zone.....	102
4.4.2	Table Short-Cut Zone .....	102
4.5	Transport Interval Zone .....	103
4.6	Manual Mode .....	104
4.6.1	Activation of Manual Mode.....	104
4.7	Free Examination Procedures.....	106
4.7.1	Free Mode.....	106
4.7.2	Auto Position Mode .....	106

# Contents

4.8	X-ray Table Examination Procedures.....	108
4.8.1	<i>Table Flexible Mode</i> .....	108
4.8.2	<i>Film Tracking Mode</i> .....	109
4.8.3	<i>Pendulum Mode</i> .....	110
4.8.4	<i>Stitching Table Mode (Option)</i> .....	111
4.9	Wallstand Examination Procedures.....	113
4.9.1	<i>Wall Flexible Modes</i> .....	113
4.9.2	<i>NoWait Configuration</i> .....	115
4.9.3	<i>Stitching Wallstand Mode (option)</i> .....	116
4.9.4	<i>AEC Technique Setup</i> .....	117
4.10	Detector, Wallstand.....	118
4.10.1	<i>14x17 inches Detector, Wallstand</i> .....	119
4.10.2	<i>17x17 inches Detector, Wallstand</i> .....	123
4.11	Portable detector, table .....	125
4.11.1	<i>Set the detector</i> .....	125
4.11.2	<i>Change Between Portrait and Landscape</i> .....	127
4.11.3	<i>Remove detector</i> .....	128
4.11.4	<i>Exchange Grid</i> .....	129
<b>5</b>	<b>Error Handling .....</b>	<b>131</b>
5.1	Fault Handling .....	131
5.1.1	<i>Notifications</i> .....	131
5.2	Diagnostic.....	133
<b>6</b>	<b>Cleaning and Disinfection .....</b>	<b>135</b>
6.1	General.....	135
6.1.1	<i>Cleaning and Disinfection Permitted with System Switched ON</i> .....	135
6.2	Cleaning .....	136
6.3	Disinfection .....	137
6.4	Maneuver Handle and Display .....	138
<b>7</b>	<b>Function And Safety Checks.....</b>	<b>139</b>
7.1	AEC Functional Check .....	139
7.2	Monthly Checks.....	140
7.2.1	<i>General</i> .....	140
7.2.2	<i>Overhead Tube Crane</i> .....	140
7.2.3	<i>Table</i> .....	140
7.2.4	<i>Wallstand</i> .....	140
<b>8</b>	<b>Complying Standards .....</b>	<b>141</b>
<b>9</b>	<b>Technical specification.....</b>	<b>143</b>
9.1	Power requirements.....	143
9.2	Power line requirements .....	144
9.3	Radiographic Specification .....	145
9.4	Collimator.....	147
9.5	X-ray Tube .....	148
9.6	Environmental Requirements.....	149
9.7	Ceiling Suspended X-Ray Tube Support.....	150
9.7.1	<i>General</i> .....	150
9.7.2	<i>Configuration</i> .....	150
9.7.3	<i>Weight</i> .....	150
9.7.4	<i>Electrical Characteristics</i> .....	150

# Contents

---

- 9.7.5      *Classification* ..... 150
- 9.7.6      *Speed* ..... 151
- 9.8        Cabinet ..... 152
- 9.9        Table..... 153
- 9.9.1      *Column* ..... 153
- 9.9.2      *Table Top*..... 153
- 9.9.3      *Weight*..... 153
- 9.9.4      *Electrical Characteristics* ..... 153
- 9.9.5      *Attenuation Equivalent*..... 153
- 9.10      Wallstand ..... 154
  
- 10 Waste Disposal ..... 155**
  
- 11 Accessories ..... 157**
- 11.1      General..... 157
- 11.1.1     *General Accessories* ..... 157
- 11.1.2     *Table* ..... 157
- 11.1.3     *Wallstand* ..... 158
- 11.1.4     *Detector* ..... 158
- 11.1.5     *Grid*..... 158
  
- 12 Appendix A..... 159**
- 12.1      Glossary ..... 159
  
- 13 Appendix B..... 163**
- 13.1      Monthly Checklist..... 163
- 13.1.1     *Overhead Tube Crane* ..... 163
- 13.1.2     *Remark* ..... 165
- 13.2      Annual Checks ..... 166

# 1 Introduction

## 1.1 Document Information

- It is important to keep this document for the life of the equipment, and pass the document on to any subsequent holder or user of the equipment.
- The original version of this manual is written in English.
- Training is provided by or via Canon Medical Systems. Training material consists of the Operator's Manual and the Installation and service manual.

### 1.1.1 System Documentation

The following documentation is available for the system:

- Omnera 500A System installation and service manual
- Omnera 500A System operation manual
- Omnera 500A System planning guide
- Image system service manual
- Image system user manual
- Detector user's manual

### 1.1.2 Stylistic Conventions

All warning label texts are shown in *italic* style in this manual.

All references are shown in *italic* style in this manual.

### 1.1.3 Document Producer

This document has been produced by:

Arcoma AB  
Annavägen 1  
S-352 46 VÄXJÖ,  
Sweden

[www.arcoma.se](http://www.arcoma.se)

### 1.1.4 Copyright © 2021 Arcoma Corporation All Rights Reserved

The reproduction, transmission or use of this document or its content is not permitted without express written authority. Offered will be liable for damages. All rights, including rights created by patent grant or registration of a utility model or design, are reserved.

# Introduction

## Document Information

---

### 1.1.5 Text Emphasis



#### **WARNING!**

---

*All texts labelled with “WARNING” call attention to potential risk to health or life.*

---

#### **CAUTION!**

---

*All texts labelled with “CAUTION” contain information about dangerous situations and measures to avoid risk.*

---

#### **Note!**

---

*All texts labelled with “NOTE” contain additional information regarding the work step, and is provided for a better understanding or as a warning about unnecessary and avoidable difficulties.*

---

### 1.2 Identification Labels

The figure shows the location of the identification labels on the equipment.

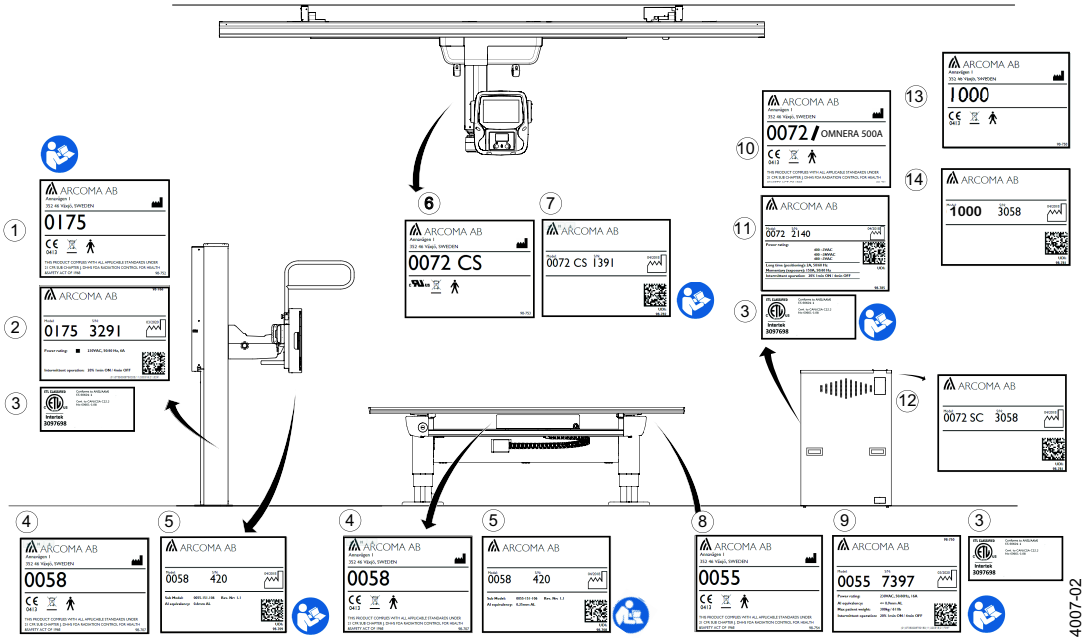

Fig. 1-1 Location of identification labels

Label 13 and label 14 apply for US market only.

4007-02

# Introduction

## Identification Labels

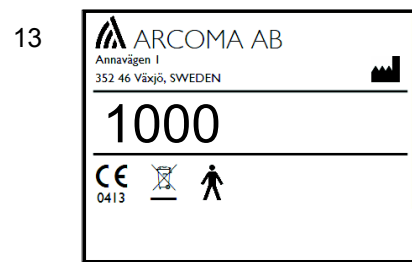
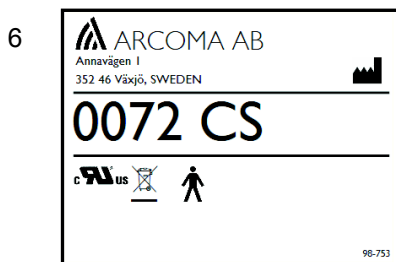
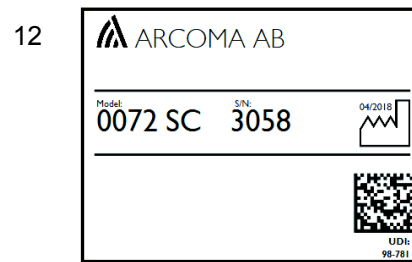
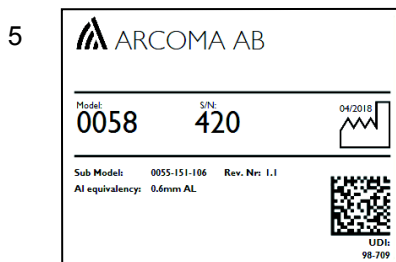
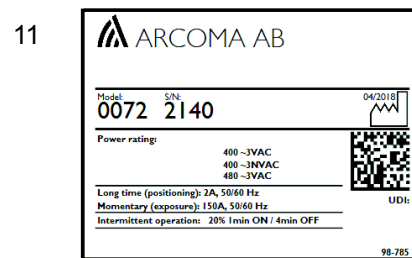
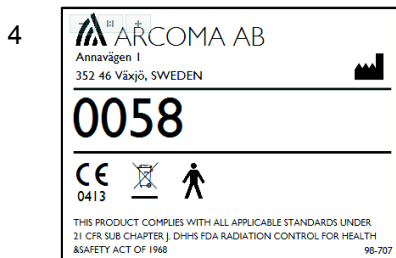
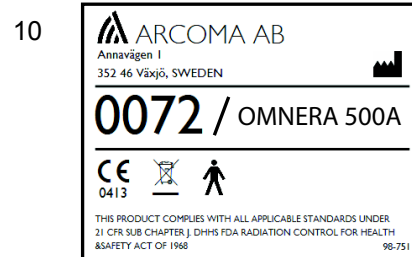
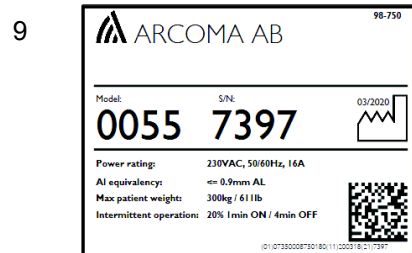
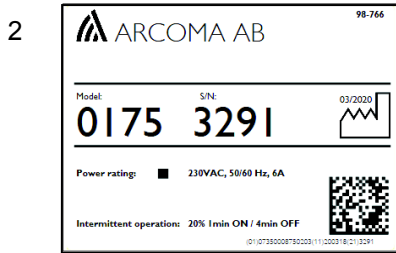
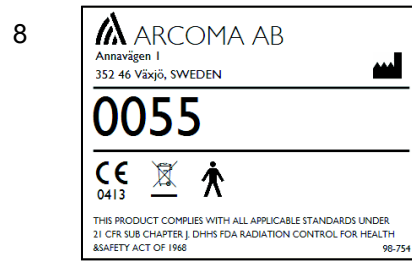
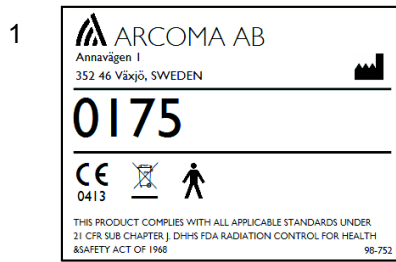

US only

4041



# Introduction

## Identification Labels

---

7



14

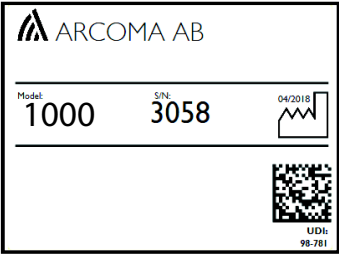

US only

### 1.3 System Description

#### 1.3.1 General

Omnera 500A includes:

- Overhead tube crane (OTC) with x-ray tube and collimator
- Table
- Wallstand
- System cabinet with a high voltage generator
- Image Acquisition system
- Flat panel detectors

#### 1.3.2 Intended Use

The system is a stationary X-ray system intended for obtaining radiographic images of various portions of the human body in a clinical environment.

The system is not intended for mammography.

#### 1.3.3 Configuration

The basic system consists of system Cabinet (including generator), Image acquisition system, Flat panel detectors, and Overhead tube crane. The basic system can be equipped with one of the following three configurations:

- Table and Wallstand
- Wallstand
- Table

##### 1.3.3.1 Table Models and Designs

The table is prepared for different types of detectors, fixed or portable in different sizes.

##### 1.3.3.2 Wallstand Models and Designs

The wallstand has different options:

- Tilttable detector holder wagon.
- Motorized Z movement
- Prepared for different types of detectors; fixed or portable in different sizes.
- The detector holder for the portable detector is available for either left-hand or right-hand loading.

### 1.3.4 System Overview

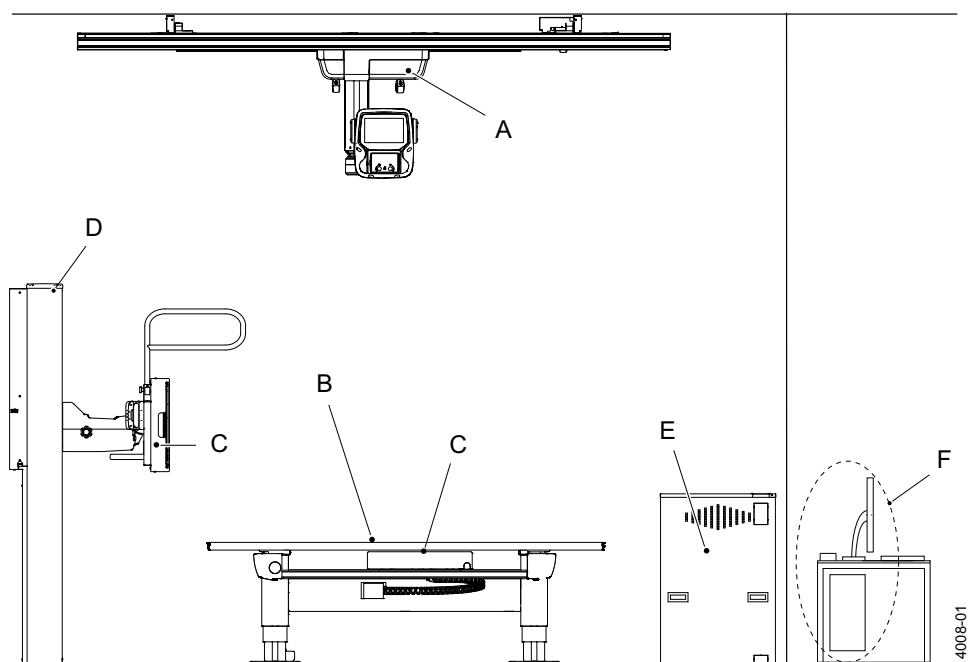

Fig. 1-2 System Overview

A Overhead tube crane  
B Table  
C Detector holder

D Wallstand  
E System cabinet  
F Computer and monitor

# Introduction

## System Description

---

### 1.3.5 Overhead Tube Crane, Overview

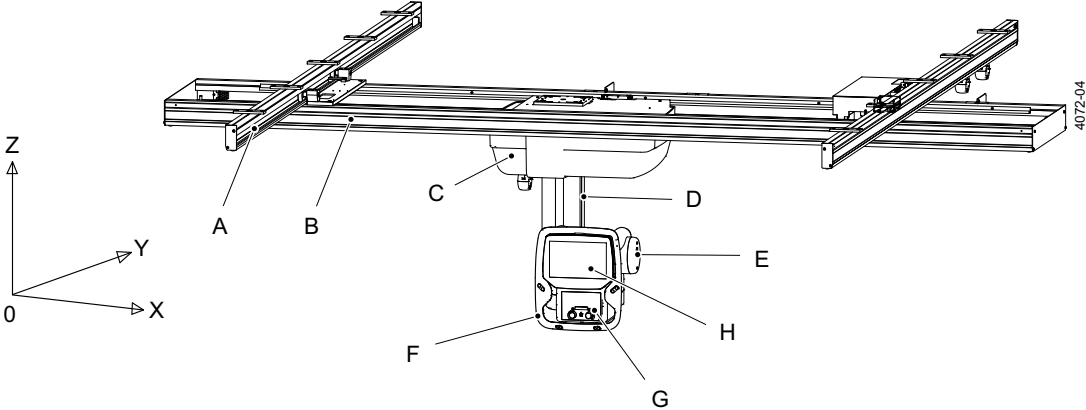

Fig. 1-3 Overhead Tube Crane

- A Ceiling rail Y
- B Traverse X
- C Ceiling wagon
- D Column (Z)
- E X-ray tube
- F Maneuver handle
- G Collimator
- H Display

### 1.3.6 Table Overview

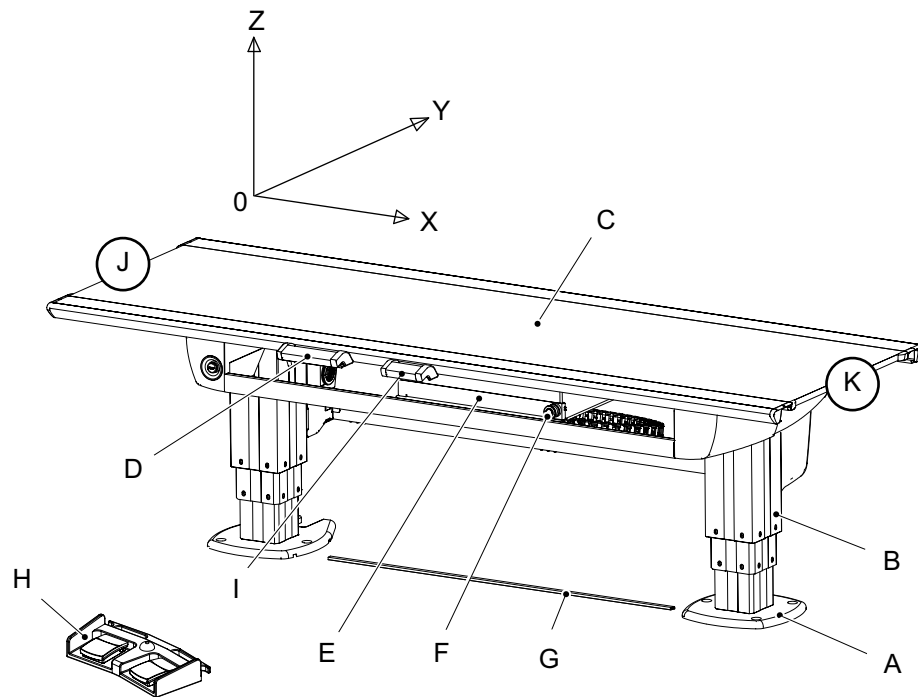

Fig. 1-4 Table overview

- |   |   |   |  |
|---|---|---|--|
| A | Foot plate  | G | XY foot control strip type (Option)        |
| B | Column  | H | Foot control table top (X/Y/Z)<br>(Option) |
| C | Table top   | I | Collimator hand control (option)           |
| D | Table hand control (X/Y/Z, Ceiling<br>tube pendulum movement) | J | Head end                                   |
| E | Detector holder   | K | Foot end                                   |
| F | Brake release for detector holder                             |   |  |

# Introduction

## System Description

---

### 1.3.7 Wallstand Overview

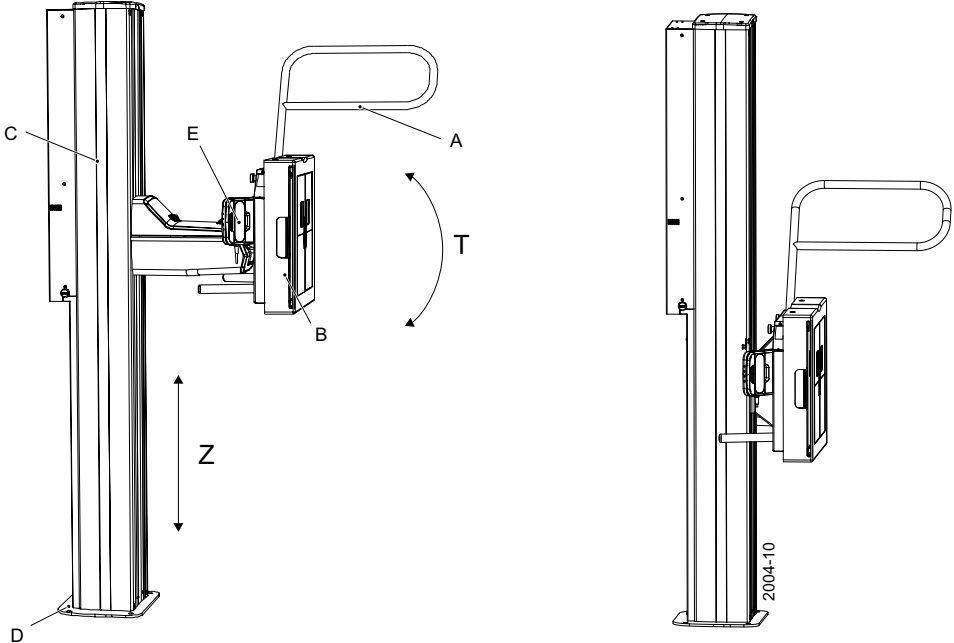

Fig. 1-5 Wallstand overview

Wallstand with tilt option

With non-tilt detector (standard)

T= Tilt

- A. Lateral armrest
- B. Detector holder
- C. Column
- D. Foot plate

- E. Hand control  
(Collimator and movement adjustments)

## 2 Safety

### 2.1 Compliance

External equipment intended for connection to signal input, signal output or other connectors shall comply with the relevant product standard e.g. IEC 60950–1 for IT equipment and the IEC 60601–series for medical electrical equipment.

In addition, all such combinations – systems – shall comply with the safety requirements stated in the general standard IEC 60601–1, edition 3.1, clause 16. Any equipment not complying with the leakage current requirements in IEC 60601–1 shall be kept outside the patient environment, i.e. at least 1.5 m from the patient support.

Any person who connects external equipment to signal input, signal output or other connectors has formed a system and is therefore responsible for the system to comply with the requirements.

If in doubt, contact qualified medical technician or your local representative.

If external equipment is connected, an isolation device is needed to isolate the equipment located outside the patient environment from the equipment located inside the patient environment. In particular such a separation device is required when a network connection is made. The requirements on the separation device is defined in IEC 60601–1, edition 3.1, clause 16.

# Safety

## Precautions, Safety

---

### 2.2 Precautions, Safety



#### **WARNING!**

*No modification of this equipment is allowed.*

---



#### **WARNING!**

*The equipment is intended for use in radiographic examinations under the guidance of trained health care professionals. Operating personnel must be familiar with the equipment and the instructions given in this manual before using the equipment.*

---



#### **WARNING!**

*Safety devices must not be removed or modified. Any modification or removal will immediately impair the safety.*

---



#### **WARNING!**

*All motorized movements shall be supervised by trained personnel.*

---



#### **WARNING!**

*Only medical-approved products shall be in the X-ray room.*

*Risk of electric shock to patient or user.*

- *No non-medical electrical devices shall be used in the x-ray room.*
  - *Note that the monitor and the PC for the Image system, are non-medical approved products.*
- 



#### **WARNING!**

*Risk of electrical hazard or damage to the system*

- *Before cleaning or disinfection, switch off the system to prevent electric shocks, for exceptions see 6.1.1 Cleaning and Disinfection Permitted with System Switched ON.*
  - *Do not spray or pour cleaning liquid on any part of the system.*  
*Use a lint-free cloth moistened with a moderate amount of liquid to avoid that cleaning liquids seep into the openings of the system, e.g., air openings, gaps between covers.*
  - *Do not restart the system if cleaning liquids have leaked in.*
-



**CAUTION!**

**Do not use any flammable or explosive gases near the device.**

---

**CAUTION!**

**Before using this device, read the manuals supplied with the devices in order to understand functions, operation, and performance. Follow the manuals for correct procedures.**

---

**CAUTION!**

**Before using the device again after a longer period of time, check the correct operation of the system.**

---

**CAUTION!**

**The system is provided with air intakes and outlets to prevent the equipment from overheating. Do not block these air intakes and outlets.**

---

**CAUTION!**

**Handle loose objects with care, so they will not fall down on patient or at the surrounding articles.**

---

**CAUTION!**

**When using this device, be sure to observe the installation environment requirements regarding temperature, humidity, and power rating conditions, or restriction of use near a device generating strong magnetic or electromagnetic waves.**

---

**CAUTION!**

**The installation environment and location, device configuration, network, power supply, and other conditions are optimized for this device. If you want to change any condition, contact your nearest service representative. Otherwise, the functions and performance of this device may be impaired.**

---

**CAUTION!**

**No objects shall be positioned within the working area. If necessary, they must be removable.**

---

# Safety

## Precautions, Safety

---

**CAUTION!**

---

**Do not put liquids, or foreign objects such as pins and clips into the equipment.**

**Otherwise, fires, electric shocks, or malfunctions may result.**

**Turn OFF the power source breaker immediately and unplug the equipment if any foreign objects have fallen into the equipment. Contact your nearest service representative.**

**Never disassemble the device.**

---

**CAUTION!**

---

**The display must not be used for diagnostic purposes.**

---

**CAUTION!**

---

**When references are made to a sub-manual, always make sure to read the Safety Chapter, Warnings and Cautions carefully in both the System Manual and the sub-manuals.**

---

**CAUTION!**

---

**Federal law restricts this device to be sold by or on the order of a physician. (US market only.)**

---

**Note!**

---

**Radio interference standard Federal Communications Commission (FCC) Part 15 Class B applies to this equipment.**

---

**Note!**

---

**The equipment may only be used as intended.**

---

## 2.3 Qualifications of Personnel

### **CAUTION!**

---

*This equipment is intended for use in radiographic examinations under the guidance of trained health care professionals.*

---

### 2.3.1 Operating Personnel



### **WARNING!**

---

*Failure to follow the instructions given in this Manual could result in serious injury to the service person, patient and operator.*

---

Before using the system it is required that the operating personnel is thoroughly familiar with the system and its operating instructions, in particular:

- Safety
- Function and Safety Checks

### **Note!**

---

*It is the responsibility of the owner to ensure that the system is operated only by trained radiologist, service technicians or product specialists.*

---

### 2.3.2 Service Personnel



### **WARNING!**

---

*Before working with service and maintenance, always turn off the power and make sure to lock it, so it cannot be mistakenly turned on.*

---

The equipment shall be serviced only by service technicians who:

- are completely familiar with the System
- have read and understood *Operator's Manual* and *Installation and Service Manual*.
- know how to remove power to the unit in case of an emergency
- are trained in the use of equipment and procedures of this type.

### **Note!**

---

*It is the responsibility of the owner to ensure that the technicians have the correct training and knowledge to perform service and maintenance.*

---

# Safety

## Service and Maintenance

---

### 2.4 Service and Maintenance



#### **WARNING!**

---

*Risk of electrical shock.*

*If covers are removed, live parts are exposed.*

---



#### **WARNING!**

---

*When service or maintenance is to be performed, the service technician shall lock the equipment from all energy sources.*

*There are live parts for some time after having switched off the mains.*

*Always wait at least 15 seconds before working on the System.*

---



#### **WARNING!**

---

*The equipment must not be serviced or maintained while in use with the patient.*

- *Risk for personal injury.*

*Service and maintenance shall only be performed when no patient is present.*

---

The equipment must be checked according to the **7 Function And Safety Checks** to maintain reliability and serviceability, and to ensure the safety of the patients, the operator, and third parties.

If national rules or regulations specify more frequent checks and/or maintenance, such regulations must be observed.

## 2.5 Installation and Repair



**WARNING!**

---

*To avoid risk of electric shock, this equipment must only be connected to a supply mains with protective earth.*

---

**CAUTION!**

---

*Only service technicians are allowed to open the covers.*

---

**CAUTION!**

---

*Do not remove, disassemble, change, modify, repair, or add any part.*

---

**CAUTION!**

---

*When installing this equipment in a different location, contact the manufacturer or the designated dealer.*

---

**Note!**

---

*For exchange of the collimator light field lamp, see the Collimator manual.*

---

Modifications of, or additions to, the system must be made in accordance with the legal regulations and generally accepted engineering standards.

The manufacturer cannot assume responsibility for the safety features and for the reliability and performance of the equipment, if:

- installation of equipment expansions or modification are not approved by the manufacturer.
- installation of equipment expansions or modification are not carried out by persons authorized by the manufacturer.
- components are not replaced by original spare parts in case of a malfunction.
- the electrical installation of the room concerned does not meet the requirements or the corresponding national regulations.
- the system is not used in accordance with the operating instructions.













# Safety

## Safety and Warning Symbols

---

### 2.6 Safety and Warning Symbols

The following symbols are used for the system.

	Attention consult accompanying documents.
	To signify a general warning. This symbol is used in various places throughout the Manual where special precaution shall be observed.
	Type B applied part.
	Protective earth terminal.
	Earth terminal.
N	Connection point for the neutral conductor on permanently installed equipment.
	Squeezing hazard.
	This symbol indicates compliance of the equipment with Directive 93/42/EEC.
	Separate collection for electrical and electronic equipment.
	Manufacturer
	Date of manufacture
	To indicate the emission or the imminent emission of X-radiation.
	Marking on the emergency stop button. Activation of the actuator interrupts all mechanical movements and prohibits exposures.

### 2.7 Safety and Warning Labels on the Equipment

The figure shows the location of the safety and warning labels.

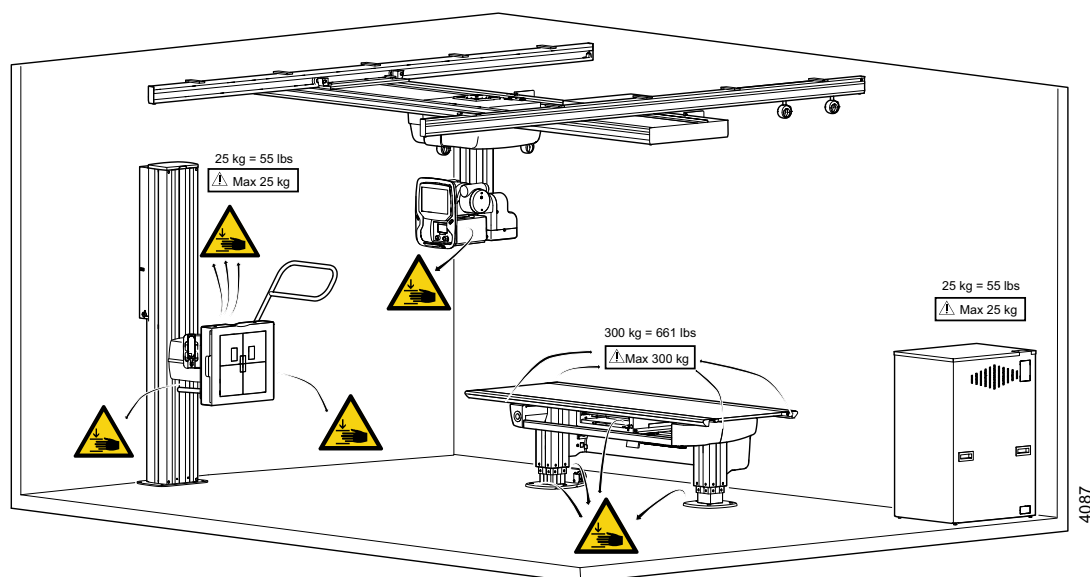

Fig. 2-1 Locations of safety and warning labels

# Safety

## Applied Parts

---

### 2.8 Applied Parts

Applied parts are intended for the patient to touch.

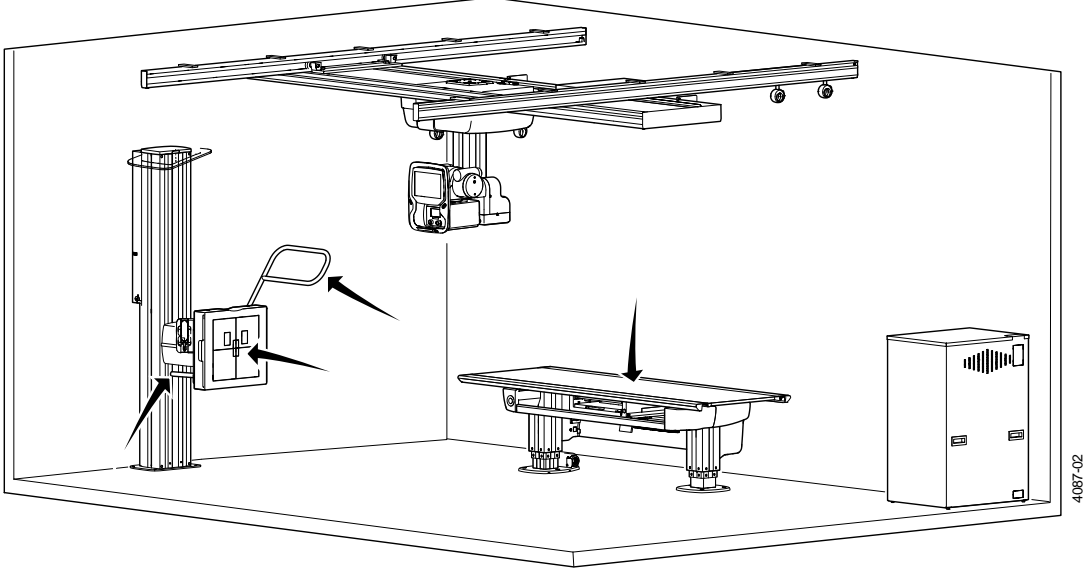

Fig. 2-2 Applied parts, System



### 2.9 Essential Performance and Basic Safety

The essential performance of the system is defined in the particular standard 60601-2-54, clause 201.4

- Accuracy of LOADING FACTORS
- Reproducibility of the RADIATION output
- AUTOMATIC CONTROL SYSTEM
- Imaging performance

These Essential Performances summarize together the functions necessary to obtain the Radiographic Image.

The equipment shall maintain basic safety while performing normal operations. The following degradations associated with basic safety shall not be allowed:

- Initiation of an unintended **non user initiated** motorized movement.
- Initiation and performing a **non user initiated** x-ray exposure.
- A **non user initiated** change of any loading parameter.

The equipment may exhibit temporally functional degradation of performance that does not affect essential performance or basic safety. Examples of such temporally functional degradation "degradation can be:

- Error or warning messages warning for a state that does not affect essential performance or basic safety.
- The system can prevent a **user initiated** xray exposure to start if an error is detected that can affect essential performance or basic safety.
- A termination of a **user generated** motorized movement.

# Safety

## Emergency Stop

---

### 2.10 Emergency Stop

*Note!*

*It is recommended to train the operator regularly in the use of the emergency stop function so the operator feels confident in using it.*

---

The System has six internal emergency stops; one connected to the overhead tube crane and one on the servo button, one on each side of the table (at the head end) and two on the wallstand.

Pressing one of the emergency stop buttons immediately cuts the power to all motorized movements. The emergency stop is also connected to the generator. The emergency stop prevents a new exposure and terminates an ongoing exposure.

A system message is displayed on the overhead tube crane display when the button is activated.

To reset the emergency stop position, turn the emergency stop button clockwise. The button is released and the system is ready for use again.

When the emergency stop is activated, lift the overhead tube crane up and push or pull sideways to change the position of the tube/collimator manually.

There are additional external emergency stops as option.

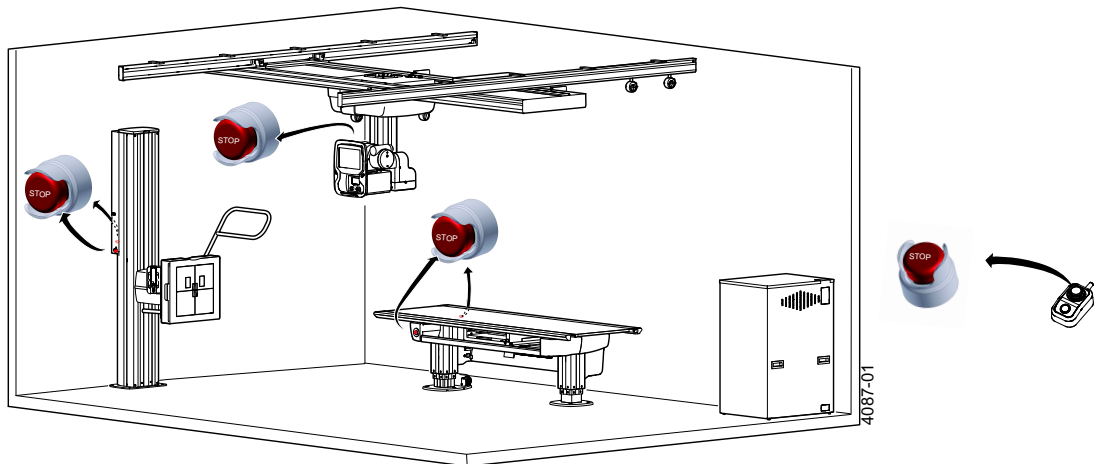

Fig. 2-3 Emergency stop buttons

## 2.11 Radiation and X-Ray Tube



**WARNING!**

*The patients, the operators and third parties must be protected against unnecessary X-ray radiation according to the local regulations.*

---



**WARNING!**

*The surfaces on the collimator and the X-ray tube can be warm.  
The X-ray tube may be up to 85 °C, the collimator will not reach 60 °C.*

---



**WARNING!**

*Verify that correct collimator filter is used during exposure.*

---

**CAUTION!**

*To minimize the X-ray dose, keep the distance between the focal spot and patient as large as possible.*

*The beam size should be as small as possible.*

---

**Note!**

*Audio and visual communication must be possible between the operator and the patient when exposure is performed.*

---

**Note!**

*The X-ray beam should not be outside the boundaries of the detector holder.*

---

# Safety

## Radiation and X-Ray Tube

---

### 2.11.1 Radiation Protection

Because of the ionizing nature of x-ray radiation, precautions have to be taken to minimize the harmful effects to patients and operators/staff during exposures. The aim is to achieve dose levels “as low as reasonable achievable”. National regulatory dose limitation requirements have to be followed.

Following four main factors control the amount (dose) of radiation received from a source:

Patient and operator dose:

**Loading factors:** Reducing the loading factors reduces the effective dose proportionally. Lower values will give more noise in the image.

**Distance:** Increasing the distance reduces dose levels according to the inverse square law.

**Beam size:** Keep the beam size as small as possible.

**Shielding:** Whenever possible/necessary protective shielding should be used to limit dose levels.

#### 2.11.1.1 Protection Against Primary Radiation (Patient)

Following measures should to be taken to limit patient dose.

- Observe national dose limit regulations.
- Exposure parameters (time/mA) should be set as low as possible with an acceptable image noise level.
- Set focus to skin distance as large as possible.
- Always collimate the exposure field to the area of interest. This will both decrease the dose level and improve the image quality (less scattered radiation).
- If possible/necessary use protective shielding.

#### 2.11.1.2 Protection Against Secondary Radiation

As the patient is the most significant source of scattered radiation during an x-ray exam, the staff and/or operator will unavoidable be exposed to ionizing radiation when inside the x-ray room during an exposure. Radiation doses from scattered radiation can be significantly high. The following safety measures should be taken to minimize scattered radiation to the staff.

- Increase the distance to the central beam to reduce dose levels according to the inverse square law.
- Use protective clothing, e.g. lead apron.
- Set the exposure parameters (time/mA) as low as possible.
- Use high kV and low mA to produce less scatter.
- Collimate the exposure field to the area of interest.
- Add collimator filter to reduce the scatter.
- Compression of patient.

### Profile of Stray Radiation For Table

The diagram below, **Fig. 2-4**, shows the dependency of the scattered radiation on the distance from the central beam, height above the floor and kV potential. The decrease of the scattered radiation is expressed in percent of the central beam exposure rate (100%). The diagram also shows the decrease of scattered radiation when using protective clothing, also this expressed in percent of the central beam dose rate.

**Fig. 2-4**, shows that a higher kV increases the scattered radiation slightly. The diagram also shows that the best way to minimize the effect of the scattered radiation is an increased distance to the patient and by using a lead apron.

Central beam exposure parameters used:

KVP: 70, 100, 120 kV

Tube current: 100 mA

Exposure time: 100 ms

Field size: 43x43 cm

Film-Focus distance: 1 m

Patient simulation: 150 mm PMMA

Filter: 0 mm

Central beam dose rate measured on top of PMMA (750 mm from focus).

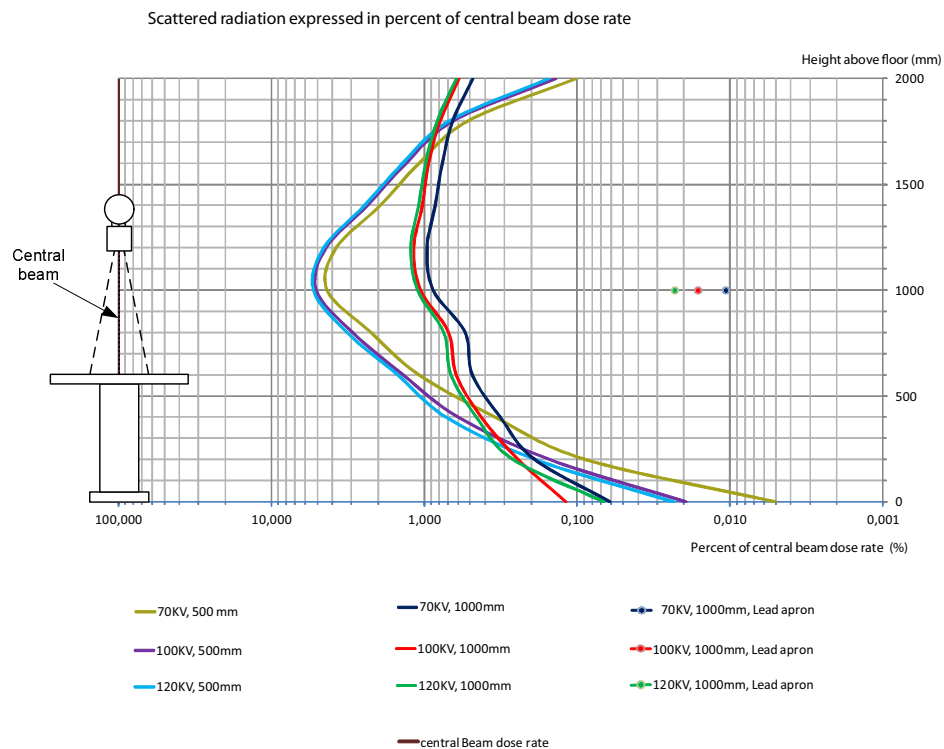
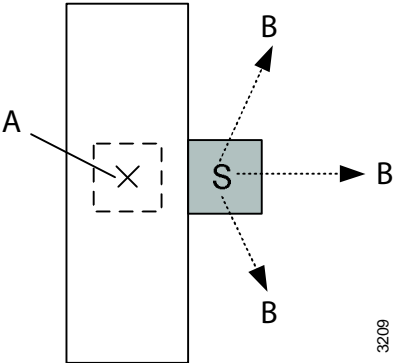

**Fig. 2-4** Scattered radiation rate expressed in percent of central beam dose rate, with and without shielding

# Safety

## Radiation and X-Ray Tube

---



**Fig. 2-5** shows a top view of the table and the zone of occupancy, where the arrows B show the direction of decreasing scatter radiation levels.

*Fig. 2-5 S = Significant zone of occupancy*

- A Central beam*
- B Decreasing*

### Profile of Stray Radiation For Wallstand

The diagram below, **Fig. 2-6**, shows the dependency of the scattered radiation on the distance from the central beam, height above the floor and kV potential. The decrease of the scattered radiation is expressed in percent of the central beam exposure rate (100%). The diagram also shows the decrease of scattered radiation when using protective clothing, also this expressed in percent of the central beam dose rate.

**Fig. 2-6** shows that a higher kV increases the scattered radiation slightly. The diagram also shows that the best way to minimize the effect of the scattered radiation is with an increased distance to the patient and by using a lead apron.

Central beam exposure parameters:

KVP: 70, 100, 120 kV

Tube current: 100 mA

Exposure time: 100 ms

Field size: 40x40 cm

Film-Focus distance: 1,5 m

Patient simulation: 150 mm PMMA

Filter: 0 mm

Central beam dose rate measured on top of PMMA (1250 mm from focus)

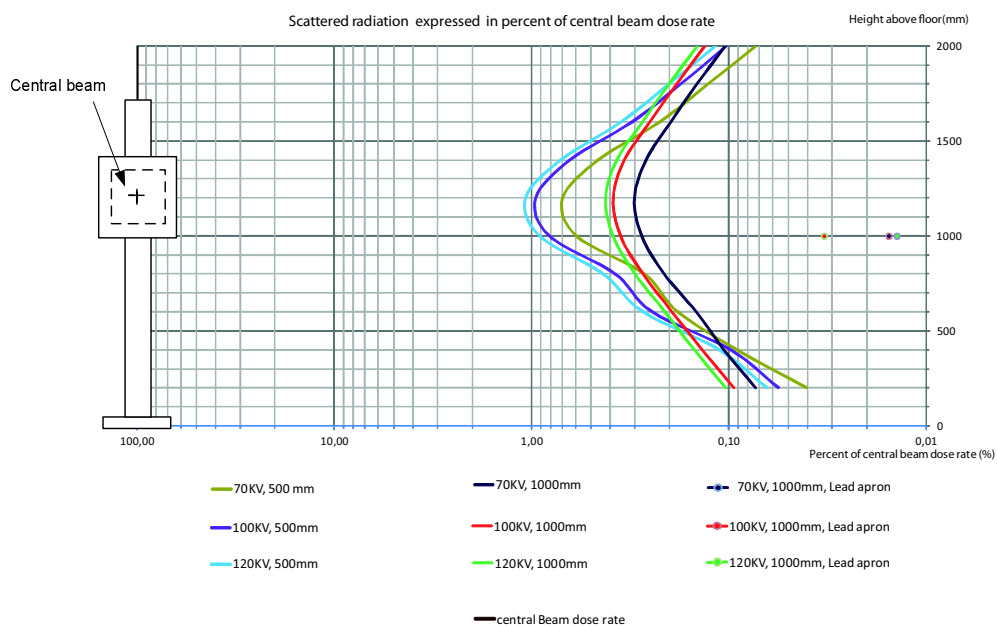

**Fig. 2-6** Scattered radiation rate expressed in percent of central beam dose rate, with and without shielding

# Safety

## Radiation and X-Ray Tube

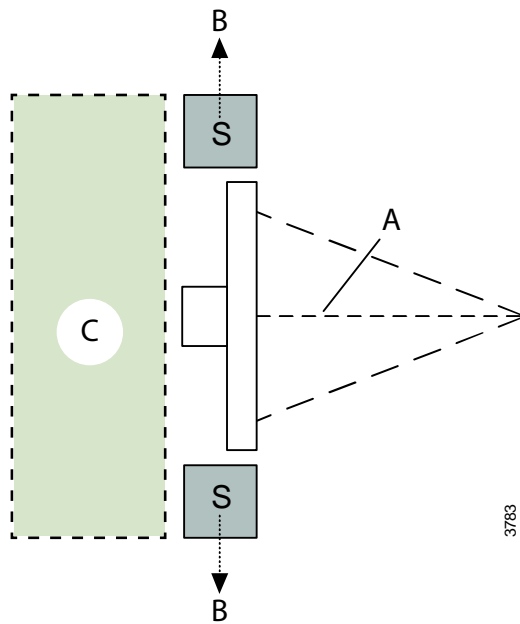

**Fig. 2-7** shows a top view of the wallstand and the zone of occupancy, where the arrows **B** show the direction of decreasing scatter radiation levels.

*Fig. 2-7 S = Significant zone of occupancy*

*A Central beam*

*B Decreasing*

*C Residual radiation area*

### 2.11.1.3 Protection Against Residual Radiation

The remaining part of the X-ray beam after having passed the plane of the image reception area (detector and detector holder) can be significantly high. Never stand behind the wallstand during an exposure, see **Fig. 2-7**.



## 2.12 Mechanical Safety

### 2.12.1 General



**WARNING!**

*All motorized movements shall be supervised by trained personnel.*

---



**WARNING!**

*Tracking shall be supervised by trained personnel.*

---



**WARNING!**

*Wheelchair patients shall always be placed outside the working area, when operating any motorized movement.*

---

**Note!**

*Surrounding equipment is not subject of the collision warning.*

---

It is the operator's duty, before any movements are activated, to ensure that any danger to the patient and/or third person is prevented.

### 2.12.2 Overhead Tube Crane



#### **WARNING!**

*Squeezing hazard between the wallstand and the table.*

*The operator should be beside the patient for support to avoid any risk of injury when handling the overhead tube crane.*

---



#### **WARNING!**

*Squeezing hazard can occur between column segments and beta rotational assembly interface.*

---



#### **WARNING!**

*Squeezing hazard can occur between the column and the plastic corner around the alpha movement.*

---



#### **WARNING!**

*Squeezing hazard can occur between support arm and high tension cable inlet to the tube.*

---

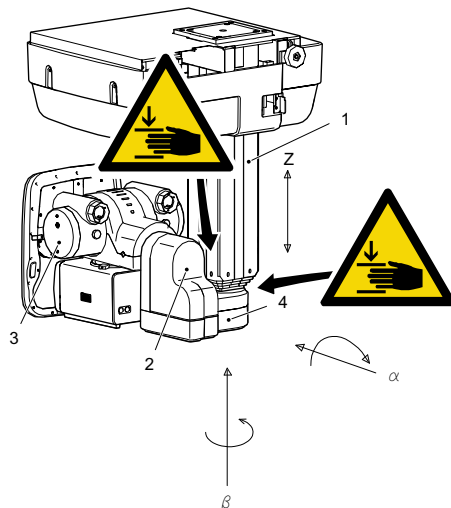

Possible squeezing hazard areas and placement of warning label:

Squeezing hazard can occur between the:

- Column (1) and the column bottom plate (4) when the column is moving upward (Z-direction).
- Cover (2) and the column (Z) when the X-ray tube (3) is moving in beta ( $\beta$ ) direction.

1. Column (Z)
2. Cover
3. X-ray tube
4. Column bottom plate

Fig. 2-8 Overhead tube crane, mechanical safety

**2.12.3 Cabinet**

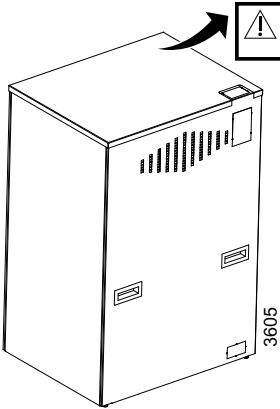

⚠ Max 25kg/ 55 lbs

Cabinet, mechanical safety  
Max 25 kg/ 55 lbs

*Fig. 2-9 Placement of warning and safety label.*

### 2.12.4 Table



#### **WARNING!**

---

**Squeezing hazard can occur between the:**

- **table top (1) and the top of the imaging unit (4); when the table top (1) is in the outer position (Y-direction) or moving in a longitudinal direction (X-direction).**
  - **table top (1) and the imaging unit rail (6); when the table top (1) is in the outer position (Y-direction).**
  - **imaging unit (4) and the cover (5); when the imaging unit is moving in a longitudinal direction (X-direction).**
  - **column (7) and the footplate (8); when the column (7) is moving downwards (Z-direction).**
  - **cover (2) and the column cover foot (3); when the column (7) is moving downwards (Z-direction).**
- 

Possible squeezing hazard areas and placement of warning labels:

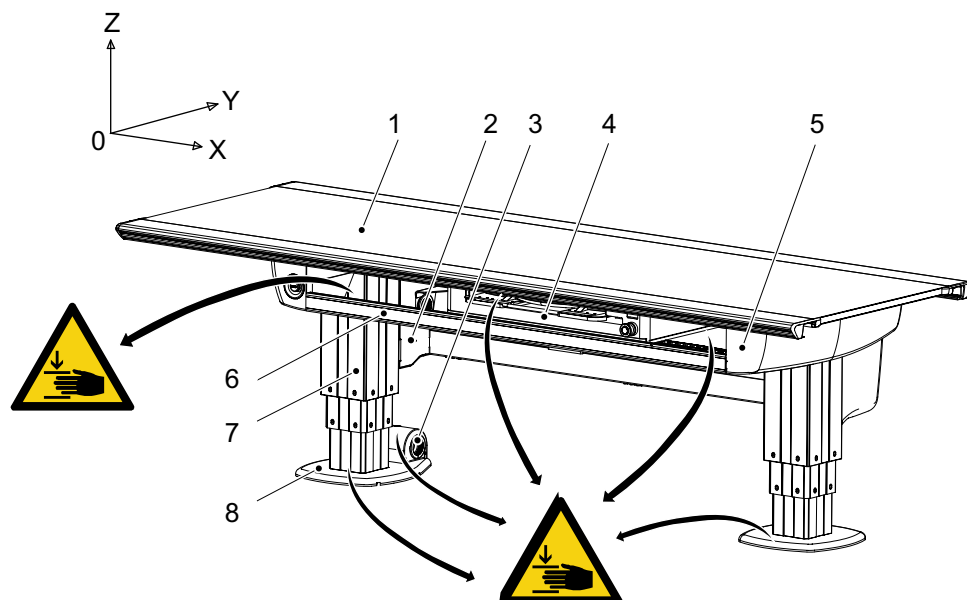

Fig. 2-10 Squeeze hazard

- |                      |                      |
|----------------------|----------------------|
| 1. Table top (X/Y/Z) | 5. Cover             |
| 2. Cover             | 6. Imaging unit rail |
| 3. Column cover foot | 7. Column (Z)        |
| 4. Imaging unit (X)  | 8. Footplate         |

**2.12.4.1 Safety Issues When Positioning a Patient**



**WARNING!**

*Be aware of unwanted motion when releasing the brakes.*

---



**WARNING!**

*Risk of injury during transfer of the patient between the hospital bed and the table.  
The hospital bed shall be placed in direct contact with and at the same height as the table.  
The table top shall be locked.*

---



**WARNING!**

*Risk of squeezing hazards.  
The patients shall always have their extremities placed over the table top.*

---

**Note!**

*Do not lean against the floating table top.*

---



**WARNING!**

*Wheelchair patients shall always be placed outside the working area, when operating any motorized movement.*

---

# Safety

## Mechanical Safety

---

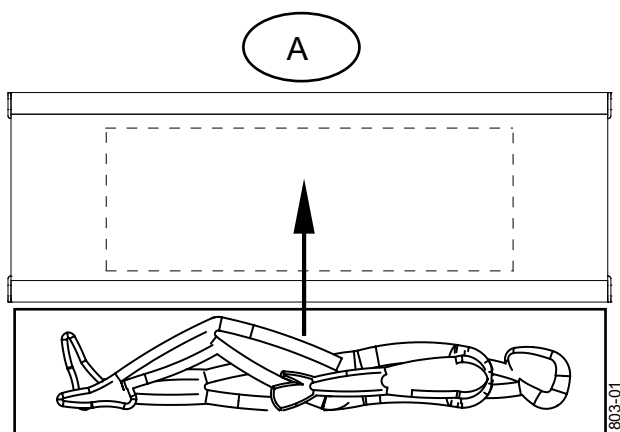

*Fig. 2-11 Transfer patient to table by operator A*

Lock and center the table top when transferring the patient to the table.

The hospital bed shall always be placed in direct contact and in the same height as the table.

To reduce the lateral forces on the table the operator should be placed on the opposite longitudinal side of the patient and the hospital bed. The operator (**A**) should drag the mattress with the patient from the hospital bed to the table.

### Patient Weight Restrictions

The following figures show the maximum load at different positions of the table.

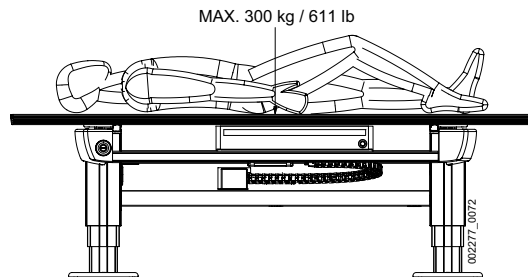

Fig. 2-12 Table top centered

Table top centered over the table frame

- Maximum load of a patient lying or sitting
  - 300 kg, see Fig. 2-12.

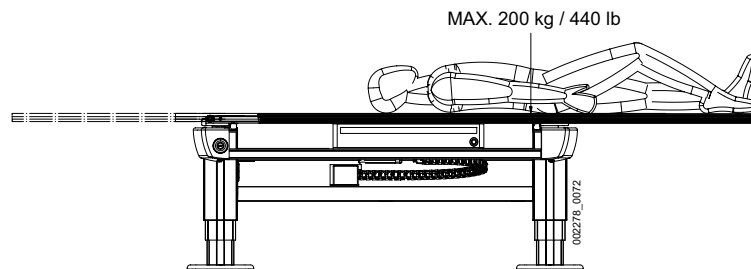

Fig. 2-13 Table top outside table frame

Table top positioned outside the table frame

- Maximum load of a patient lying on the table top:
  - 200 kg, see Fig. 2-13.
- Maximum load of at patient sitting on the table top:
  - 150 kg.

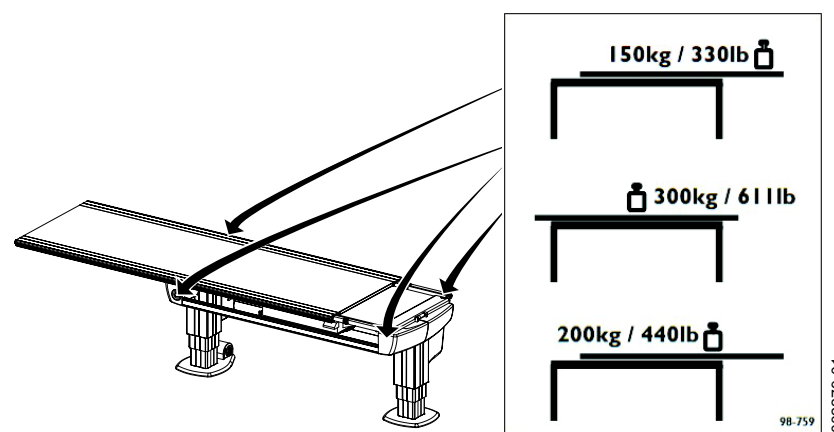

Fig. 2-14 Maximum patient weight label

The table frame is marked on the upper side with the maximum weight when positioning in outer positions, see Fig. 2-14.

# Safety

## Mechanical Safety

---

### 2.12.4.2 Working Area, Table



#### **WARNING!**

---

***Risk of squeezing hazard.***

***Patients shall be outside the working area or placed on the table, when operating any motorized movement.***

---



#### **WARNING!**

---

***Risk of squeezing hazard.***

***All obstacles placed within the working area, must be moveable for easy patient release.***

---

#### **CAUTION!**

---

***To avoid any injuries to patient, user or damage to system, peripherals should always be placed outside the working area.***

---

The working area comprises the table top including the stroke length of the table top in the X- and Y-direction. The measurements in the figure show the length of stroke in the X- and Y-direction. The dimensions have some tolerances and can differ from the manufacturer's.



**Two Column Table**

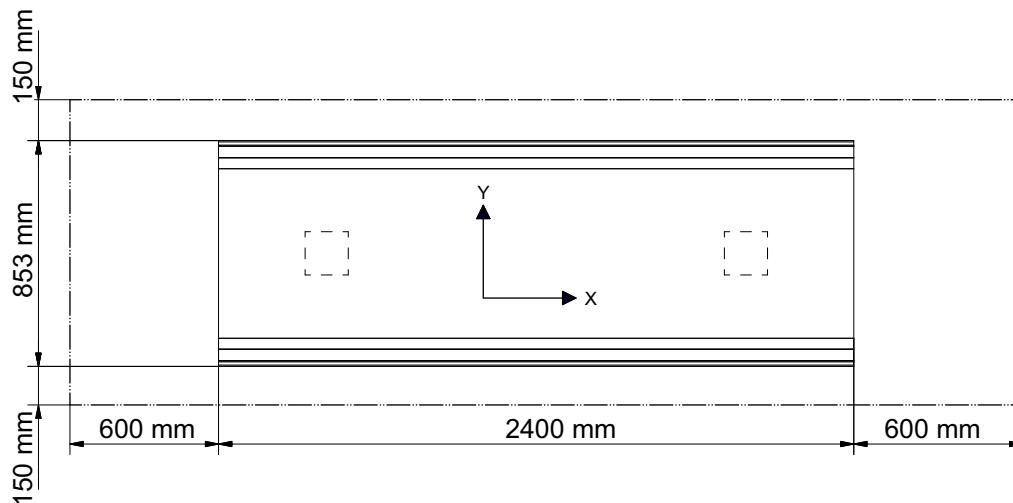

*Fig. 2-15 Table top stroke length*

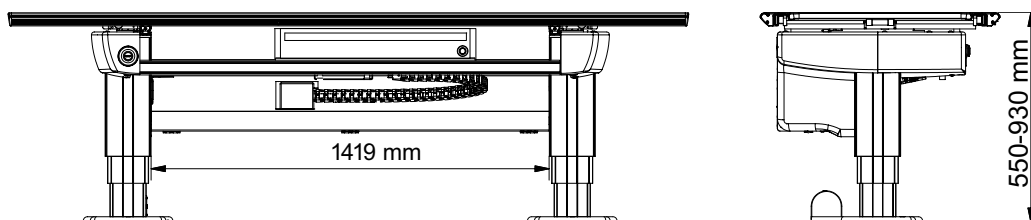

*Fig. 2-16 Working area underneath table*

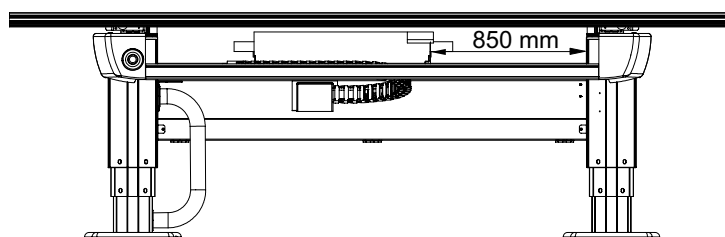

*Fig. 2-17 Detector movement*

The detector movement is up to 850 mm, depending on detector type.

# Safety

## Mechanical Safety

---

### 2.12.5 Wallstand

#### 2.12.5.1 Safety Issues When Positioning Patient



#### **WARNING!**

***Be aware of unwanted motion when releasing the brakes.***

---

#### **Note!**

*Maximum weight on the wallstand lateral armrest is 25 kg/ 55 lbs.*

---

#### 2.12.5.2 Working Area, Wallstand

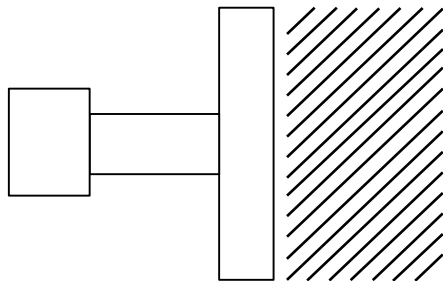

The working area of the wallstand is the area in front of the detector holder.

3784

Fig. 2-18 Working area, wallstand

### 2.12.5.3 Standard Version



#### **WARNING!**

**Risk of squeezing between the tilted image receptor holder and the floor.**

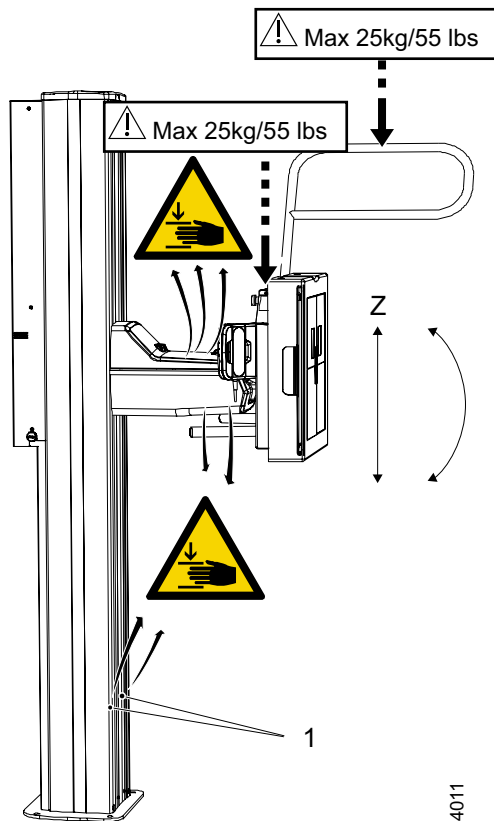

Getting stuck in the slide opening is a squeezing hazard when the detector holder is moving downward (Z-direction).

Possible squeeze hazard areas and placement of warnings and safety labels:

The system is balanced with counterweights and whenever any item is removed from the wallstand it becomes unbalanced. If the brake is released when the wallstand is unbalanced, the detector holder moves and can cause injury.

Fig. 2-19 Possible squeeze hazards

1. Slide opening of detector wagon

### 2.12.5.4 Motorized Wallstand

#### **CAUTION!**

**Patients shall be outside the working area when operating any motorized movement.**

## 2.13 Safety Functions

### 2.13.1 Table Safety Zone and Overhead Tube Crane

There is a safety zone over and around the table. The safety zone reaches from the table top surface and vertical up 500 mm and from the table top edge and horizontal out 120 mm.

Inside the zone, the overhead tube crane moves vertically with reduced speed. Not until the overhead tube crane is outside the zone the vertical movements are performed with full speed.



#### **WARNING!**

---

*When the stand has passed the table top level, on its way downward, the speed increases to normal speed again.*

---

Additionally, when the stand moves manually down into the zone, at a distance of 50 cm from the table, the overhead tube crane stops the vertical movement and the movement has to be restarted by releasing and pressing the button again.

### 2.13.2 Wallstand Safety Zone

With consideration of detector tilting and the safety height of the tube, there is a collision validation when moving in Auto-position. The System validates if it is possible to move to the position, without any collision between tube and detector.

In *Wall Flexible mode*, when user activates the *Servo* button and Z reaches the transport interval zone, the System checks the Auto-position target with the detector tilting and the safety height of the tube to detect possible collision points. The System then moves, or stops moving and displays a message.

### 2.13.3 Collision Detection

#### 2.13.3.1 Motorized Movements

Every motorized movement has a collision detection.

All movements are stopped when the collision detection activates and the display shows an error message. When a collision in Z-direction is detected, the overhead tube crane has to be moved in the opposite direction before it can be moved in the original direction again.

#### 2.13.3.2 Z Column

A guard plate, installed on top of the column, registers vertical pressure on the column, for instance a vertical impact.

When the pressure exceeds the trig level vertically, all movements are stopped and a warning message is displayed. To release the pressure, a movement in the opposite direction is allowed. When the pressure on the column has returned to normal, see **Fig. 2-20**, the warning message is removed and motorized movements are allowed again.

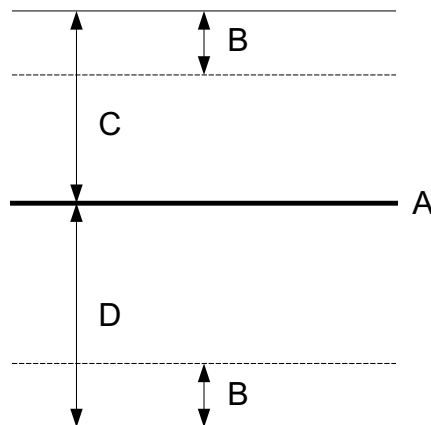

Fig. 2-20 Collision detection

A Zero force level  
B Hysteresis

C Upper trig level  
D Lower trig level

### Note!

In some situations it is possible to force a false detection of a collision. This can occur if the column is affected by a pressure at the time the movement starts. This could be for example the case if the collimator rests on the Table, when the operator moves the column upward, a collision is detected.

The reason for the collision detection is that, when the movement starts, the zero force level is calculated based on the actual pressure affecting the column at that moment. As soon as the movement starts and the collimator is no longer resting on the Table, the guard plate catch a change in pressure and a collision is detected.

To solve the problem the operator must affect pressure on the column, for example manually pull the column up or down. The System will take this as a sign that the operator has removed the obstacle and that no collision exists any more. If the problem is yet not solved, the System must be restarted.

### 2.13.3.3 Motor Nodes

Every motor node has a collision detection on their own movements. A detected collision makes the stand stop all movements and display an error message. A collision can be detected in different ways, for instance, if:

- The control error in the motor node's regulator is too large.
- The final position is not reached in time.
- The position transducer has not moved although the drive unit had an output voltage for a given time.

### 2.13.3.4 Malfunctioning Node

If any node stops functioning, all movements are stopped and the power to the motors in the System is removed.

### 2.13.4 Dead Man's Grip

All buttons for motorized movements require constant activation. If the operator releases one of the buttons/controls, the System will immediately stop or engage the brakes (manual movements). The exposure hand control has the same functionality.

# Safety

## Electromagnetic Compatibility (EMC)

---

### 2.14 Electromagnetic Compatibility (EMC)

The system complies with the requirements of IEC 60601-1-2:2014 regarding electromagnetic compatibility. Surrounding equipment shall follow the standard IEC 60601-1-2:2014.



---

**WARNING!**

*Do not use this equipment adjacent to or stacked with other equipment. Such use could lead to improper operation. Verify that the equipment is operating normally, if such use is necessary.*

---



---

**WARNING!**

*Do not use other accessories, transducers and cables than those specified or provided by the manufacturer. Such use could lead to increased electromagnetic emissions or decreased electromagnetic immunity of this equipment and result in improper operation.*

---



---

**WARNING!**

*Do not use portable RF communications equipment (including peripherals such as antenna cables and external antennas) closer than 30 cm (12 inches) to any part of the system, including cables specified by the manufacturer. Such use could lead to degradation of the performance of this equipment.*

---

---

**CAUTION!**

*Do not place the system near MRI equipment or other equipment that generates a strong magnetic field.*

---

---

**CAUTION!**

*Mobile telephones and other radiating equipment can interfere with the function of the system and can therefore cause safety hazards.*

---

The system is intended for use in the electromagnetic environment specified below. The customer or the user of the system should assure that it is used in such an environment.

<b>Guidance and manufacturer's declaration - electromagnetic emissions</b>		
<b>Emissions test</b>	<b>Compliance</b>	<b>Electromagnetic environment - guidance</b>
RF emissions CISPR 11	Group 1	The system uses RF energy only for its internal function. Therefore, its RF emissions are very low and are not likely to cause any interference in nearby electronic equipment.
RF emissions CISPR 11	Class B	The system is suitable for use in all establishments, other than domestic and those directly connected to the public low-voltage power supply network that supplies buildings used for domestic purpose. For information purpose the system complies with IEC61000-3-11 and is suitable for connection to public mains network if the impedance is 0.32 Ohm or lower
Harmonic emissions IEC 61000-3-2	Not applicable	
Voltage fluctuations/ Flicker emissions IEC 61000-3-3	Not applicable	

Guidance and manufacturer's declaration - electromagnetic emissions.

See 1000-095-072 Installation and Service Manual for tables including IEC 60601 test and compliance levels, and recommended separation distances between portable and mobile RF communications equipment and system.

# Safety

## Electromagnetic Compatibility (EMC)

---



## 3 User Interface

### 3.1 Overhead Tube Crane

The overhead tube crane (OTC) can be moved to the correct position by autopositioning, motorized movements or manual movements.

The overhead tube crane has a display that shows patient information, information of the tube angulation and the selected workstation, etc. The exposure parameters are shown and can easily be changed from the OTC.

#### 3.1.1 Direction of Movement

Fig. 3-1 shows the movements of the overhead tube crane.

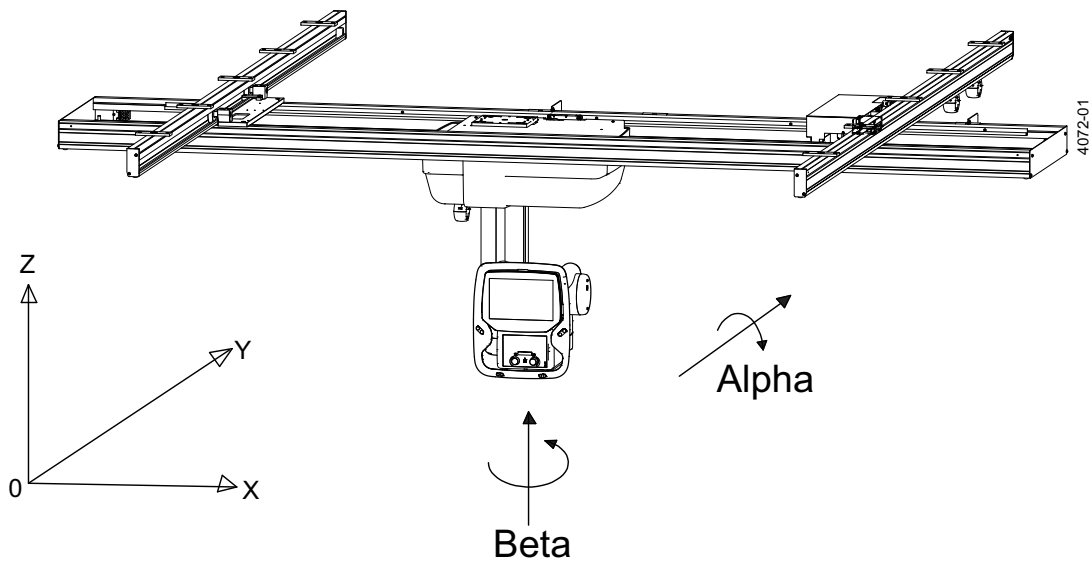

Fig. 3-1 OTC direction of movement

Z	Vertical movement	Motorized
Y	Lateral movement	Motorized and manual
X	Longitudinal movement	Motorized and manual

#### 3.1.2 Sound Signal

- One sound signal means that the overhead tube crane is in position and ready for exposure.
- Two sound signals, in rapid succession, indicates a fault and the display shows an error message, for example after a collision. The error message shows the corrective action.

# User Interface

## Overhead Tube Crane

### 3.1.3 System Display Overview

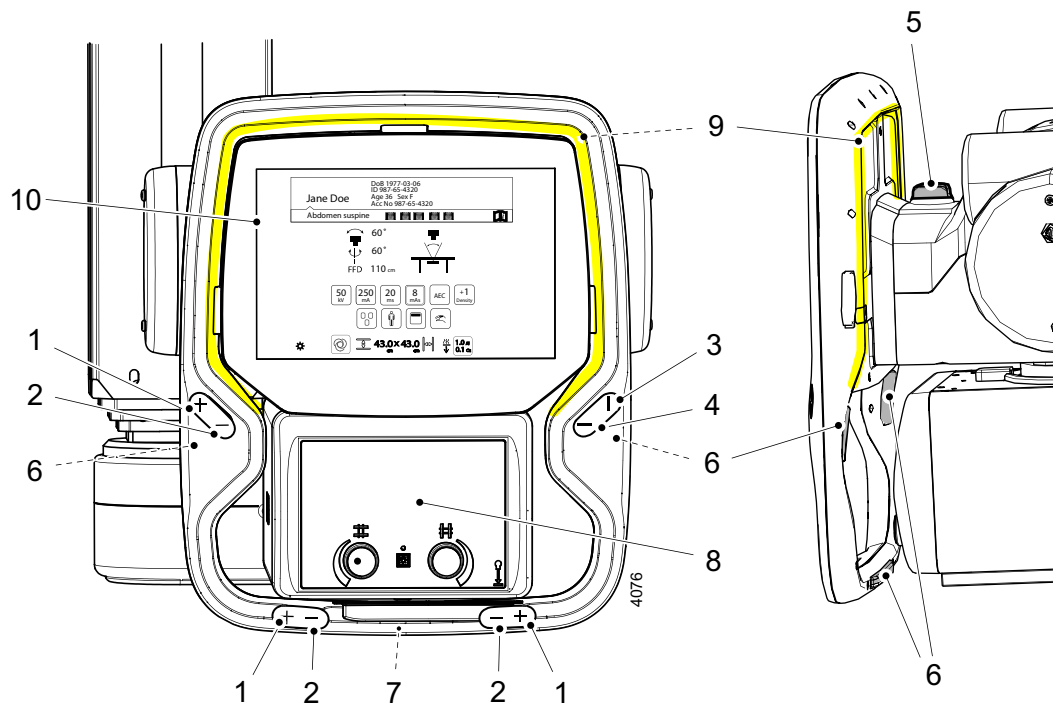

Fig. 3-2 System Display Overview

- |  |   |
|--|---|
| <ul style="list-style-type: none"> <li>1. Up</li> <li>2. Down</li> <li>3. Y direction</li> <li>4. X direction</li> <li>5. Emergency brake (rear side)</li> <li>6. Release X-Y-direction and rotation (alpha/beta) (rear side)</li> </ul> | <ul style="list-style-type: none"> <li>7. Release in X-Y direction (rear side)</li> <li>8. Automatic collimator, see <b>3.2.1 Automatic Collimator</b></li> <li>9. Light indication, see <b>3.3.12 Light Indication</b></li> <li>10. Display user interface, see <b>3.3 Display User Interface</b></li> </ul> |
|--|---|

### 3.2 Automatic Collimator Control

The collimator is used to adjust the size of the x-ray field to cover the area of interest of the patient by adjusting the collimator light field size. The collimator light field size / x-ray field size and the collimator filtration can be predefined in the anatomical protocols and is then set automatically when the protocol is selected. The size of the light / x-ray field and the filtration can then be adjusted when needed to adapt to the patient.

The collimator can be operated from the collimator interface at the Overhead tube crane, from the hand control at the wall stand or from the control handle at the table (option).

The following figure shows the functions of the automatic collimator.

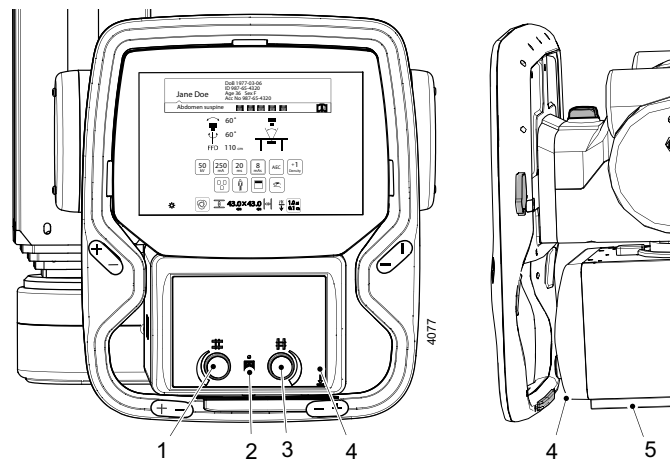

Fig. 3-3 Display, automatic collimator

1. Knob for adjusting collimator light/x-ray field height
2. Collimator light and laser light on/off.  
Automatic off after predefined time.
3. Knob for adjusting collimator light/x-ray field width
4. Measuring tape grip for SID measurement, graduation in cm/inch -  
Take reading at bottom edge of multi-leaf collimator.
5. Accessory rail

The collimator can rotate around the central beam axis  $\pm 90^\circ$ .

#### 3.2.1 Automatic Collimator

Fig. 3-4 Automatic collimator

1. Select Automatic or Manual mode of the collimator.

**Note!**

If there is no new examination and the System is in Manual mode, the collimator ignores the instructions of sent collimator area from the Imaging system. This can be useful if the collimator area is intended to be kept for the next examination.

2. Collimator light/x-ray field height x width
3. Collimator filter selection

# User Interface

## Automatic Collimator Control

---

### 3.2.1.1 Collimator Mode

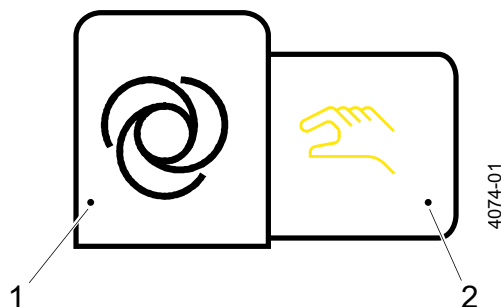

In automatic mode, the collimator light height and width is set from the anatomical program. The collimator light size can still be changed manually. In manual mode the collimator light height and width is not set from the anatomical program.

1. Automatic mode
2. Manual mode

Fig. 3-5 Collimator mode

When Automatic mode is selected, the predefined values of the collimator light / x-ray field size and the filter selection are set automatically when the anatomical protocol is selected. Both the light / x-ray field size and the filter can be changed when needed. In automatic mode the maximum light / x-ray field size is restricted to the maximum active area of the imaging unit.

When manual mode is selected the size of the collimator light / x-ray field size can be adjusted outside of the maximum active area of the imaging unit. When a new anatomical protocol is selected (for the same patient) the collimator light / x-ray field size or the filtration is not changed even if size and filtration is defined different in the protocol.

When changing from Manual mode to Automatic mode the collimator light / x-ray field size and filtration is restored to the values that were selected when changing from automatic to manual mode. Example:

- Automatic mode: Size: 30 cm x 10 cm; filter 1.
- Changes to Manual mode. Changes: Size: 30 cm x 20 cm, filter 2.
- Changes back to Automatic mode: Size 30 cm x 10 cm, filter 1.

When a new patient is selected Automatic mode is automatically activated.

### 3.2.1.2 Collimator Filtration Selection

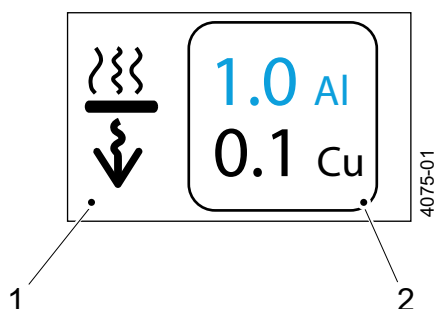

Fig. 3-6 Collimator filtration selection

The user can change the selected value from the display.

1. Collimator filtration selection icon
2. Collimator filtration selection values

### 3.2.1.3 Collimator Filters

The collimator filter options are:

- No added filtration
- Filter 1 =1 mm Al + 0.1 mm Cu
- Filter 2 =1 mm Al + 0.2 mm Cu
- Combined: 2 mm Al + 0.3 mm Cu

The filters can be predefined in the anatomical protocol and also be changed if needed

### 3.2.1.4 Laser

The laser can be switched off by applying a mechanical cover over the laser. The cover is available underneath the collimator.

### 3.2.1.5 Collimator Functionality - System

When the overhead tube crane moves in a direction that changes the SID, the collimator starts to compensate the field size. The collimator light field size on the imaging unit is held constant with changing SID.

When the overhead tube crane is tracking against the Wallstand or when the table top is released, the collimator light automatically is turned on. This is make it easier to directly find the correct stand and patient position.

In *Free mode/Auto position* mode the position of the detector is unknown for the System. The indicated size of the light field is correct at the shown SID.

# User Interface

## Automatic Collimator Control

### 3.2.1.6 Collimator Control Handle, Table (option)

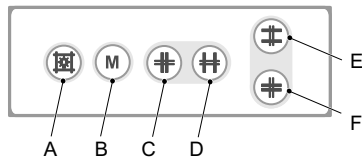

Fig. 3-7 Table collimator control handle

- A. Button for switching the light and the laser line on/off. The light and laser line is automatically switched off via a time switch.
- B. Button for changing between *Automatic mode* and *Manual mode*.

A long activation of the *M button* sets the light field to max image size, based on the pre-programmed SID value and the selected receptor.

- C. Button for closing the format height collimation.
- D. Button for opening the format height collimation.
- E. Button for opening the format width collimation.
- F. Button for closing the format width collimation.

### 3.2.1.7 Hand Control, Wallstand – Collimator Adjustment

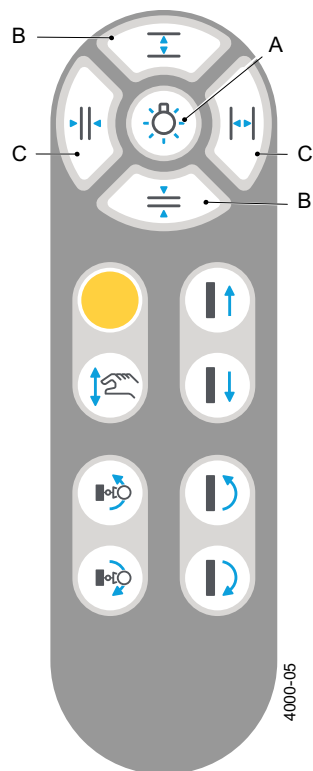

- A. Collimator light on/off
- B. Adjustment height collimation
- C. Adjustment width collimation

Fig. 3-8 Hand control

### 3.3 Display User Interface

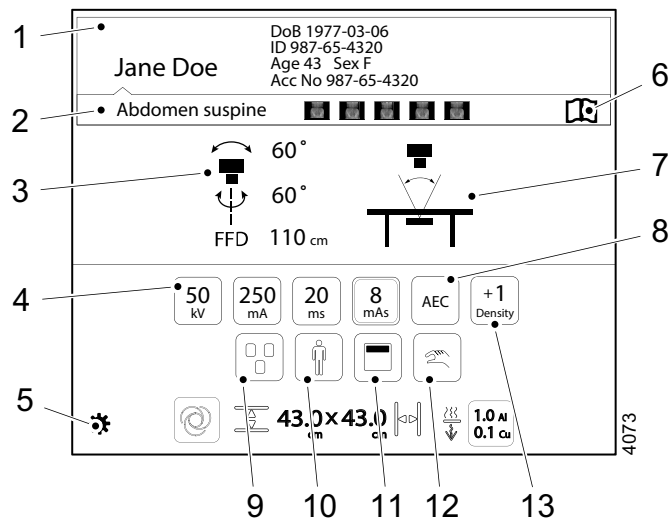

Fig. 3-9 Display user interface

1. Patient information
2. Active protocol
3. Position information
4. Adjustment of generator parameters: kV, mA, ms, mAs
5. Select the settings menu
6. Hospital method book
7. Active System mode
8. Selection of Technique mode
9. Selection of active AEC field (AEC mode only)
10. Patient size
11. Collimator centering
12. Manual or Servo mode
13. Density

See the following pages for detailed description of the functions.

### 3.3.1 Patient Information

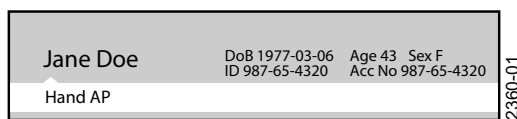

Fig. 3-10 Patient information always shown

The following information can be shown in the Patient Information field:

- Patient Name
- Patient ID
- Date of Birth
- Age, Sex
- Accession number

The information shown is defined in the *Setting menu*. In the *Setting menu* it is also possible to decide if the *Patient information* shall be shown always as in **Fig. 3-10** or on demand as in **Fig. 3-11**.

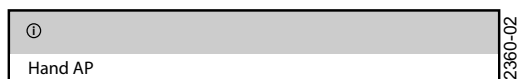

Fig. 3-11 Patient information shown on demand

When the button is shown on demand, the *Patient information* can be obtained by pushing the "i" on the black bar.

The *Patient information* closes automatically, or when the bar is pushed once again.

### 3.3.2 Position Information

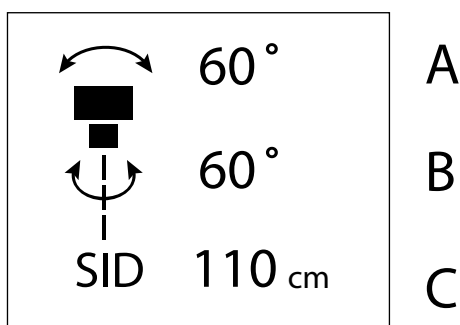

Fig. 3-12 Position information

- A Alpha angle (°)
- B Beta angle (°)
- C Source Image Distance (SID), or Height to floor (H) in Free or Auto Position Mode (cm/inch)

The height to floor (H) is shown in *Free mode* and *Auto position mode*. In all other modes the source image distance (SID) is shown.

The unit for the distance can be either cm or inch, and is set in the *Setting menu*, see **Fig. 3-21**.



### 3.3.3 Adjustment of Generator Parameters (kV, mA, ms, mAs, Density)

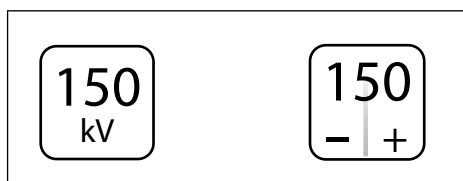

- Push the button with the parameter that shall be changed to change the exposure values.
- Select to increase or decrease the value.

*Fig. 3-13 Adjustment of generator parameters*

#### **Note!**

---

*The Operator/User is always responsible for checking and validating the exposure parameters in the Image system before performing exposure.*

---

# User Interface

## Display User Interface

---

### 3.3.4 Settings

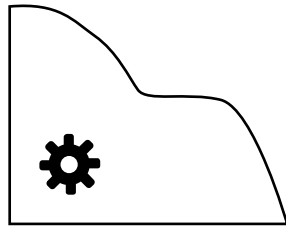

- Press the *Setting* button for 1 second to reach the Settings menu.

Fig. 3-14 Setting button

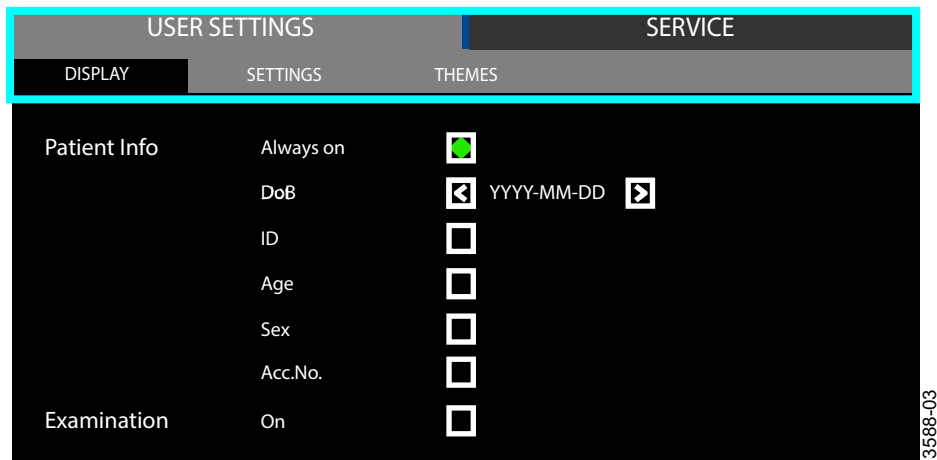

Fig. 3-15 Settings menu

The Settings menu has the following tabs:

- USER SETTINGS
- SERVICE

The USER SETTINGS menu has the following tabs:

- DISPLAY
- SETTINGS
- THEMES

The SERVICE menu has the following tabs:

- LOG
- SETTINGS
- DISPLAY

### 3.3.4.1 User Settings – Display

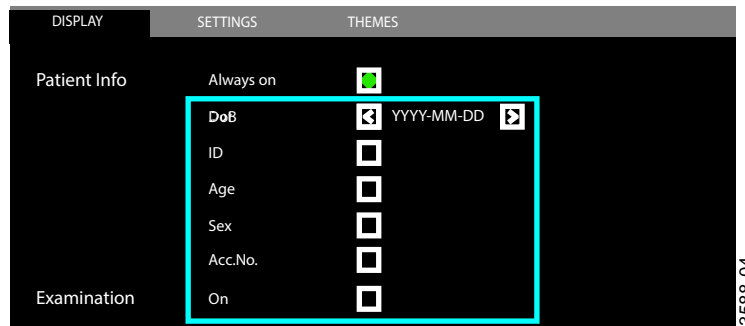

Fig. 3-16 Tab DISPLAY — Patient info

It is possible to select which patient information to show on the display. The following parameters can be selected:

- DoB; Date of Birth, where the following formats are selectable:
  - YYYY-MM-DD
  - DD-MM-YYYY
  - MM-DD-YYYY
- ID; the identity of the patient
- Age; the age of the patient
- Sex; the sex of the patient
- Acc.No; Accession number
- Examination – On; Examination/Active Protocol

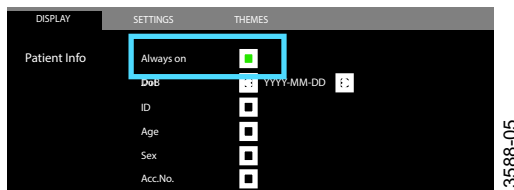

Fig. 3-17 Selection of Always on/off

The first line in USER SETTINGS menu, tab DISPLAY, refers to the selection if Patient information shall be shown (Always on) or not on the OTC display.

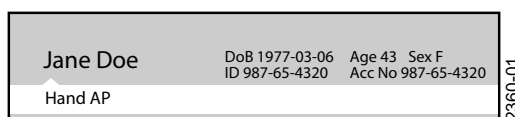

Fig. 3-18 Always on selected

When Always on is marked, patient information is shown as soon as the patient is selected.

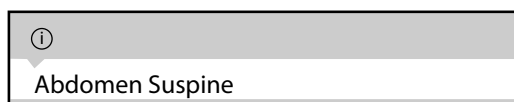

Fig. 3-19 Always on not selected.

When Always on is **not** marked, the Patient info is shown when pushing the black field with the ⓪

The Patient info closes automatically or by pushing the black field with the ⓪ again.

# User Interface

## Display User Interface

### User Settings – Settings

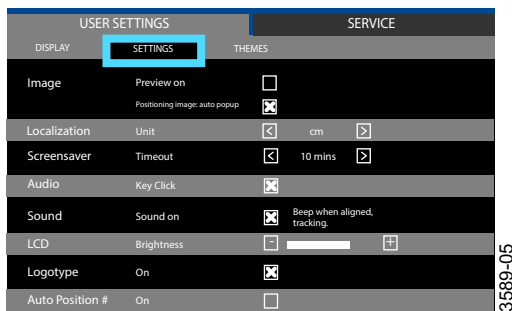

Fig. 3-20 Menu USER SETTINGS – tab SETTINGS

In the SETTINGS tab it is possible to adjust the following:

- Preview Image
- Localization, unit selection
- Screensaver, set time for activation
- Audio key click, On/Off
- Sound, On/Off
- LCD brightness, Plus/Minus
- Logotype in display, On/Off
- Autoposition, On/Off

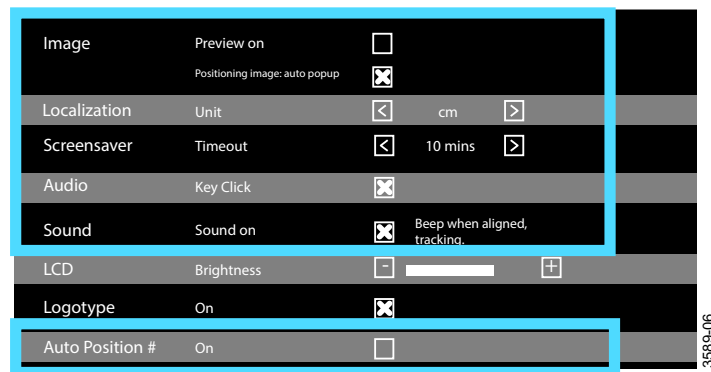

Fig. 3-21 Menu USER SETTINGS – tab SETTINGS

- Image – Preview on  
Position image: auto popup
- Localization – Unit
- Screensaver – Timeout
- Audio – Key Click
- Sound – Sound on
- Auto Position #

By selecting **Preview on** a small preview image is shown next to the Active Protocol name, see Fig. 3-22.

**Unit** changes between cm and inch, for collimator light width and height values and SID/H.

Select **Screensaver – Timeout** to activate screensaver and set the time (Off — 10 mins — 1 hour) for activation using < or > .

By selecting **Key Click** a key click is heard when touching the System display.

By selecting **Sound – Sound on** a beep is heard when overhead tube crane is aligned with the detector, at tracking.

By selecting **Auto Position #** the auto position # is shown in the OTC display.

### Preview Image



### **WARNING!**

**The preview image must not be used for diagnostics or positioning.**

It is possible to select if a preview image shall be shown on the touchscreen display or not by selecting Image – Preview on, see Fig. 3-21.

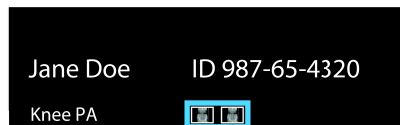

Fig. 3-22 Preview image displayed

If preview is selected, a small preview image, see Fig. 3-22, is shown on the touchscreen display when an exposure is performed.

Touch the small image on the display, and the image is shown as a large image.

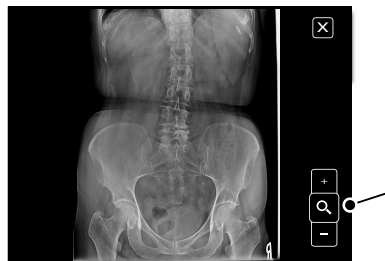

Fig. 3-23 Preview image enlarged

Touch the zoom button +/- to zoom in and out in the image.

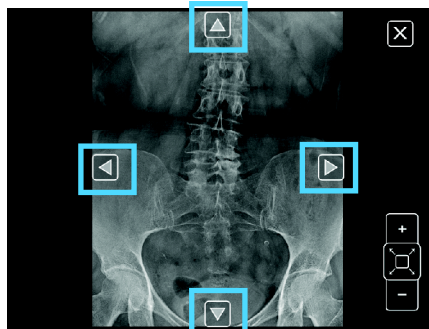

Fig. 3-24 Zooming In/Out

Use the arrows appearing in the image to pan in the image.

# User Interface

## Display User Interface

---

### LCD and Logotype

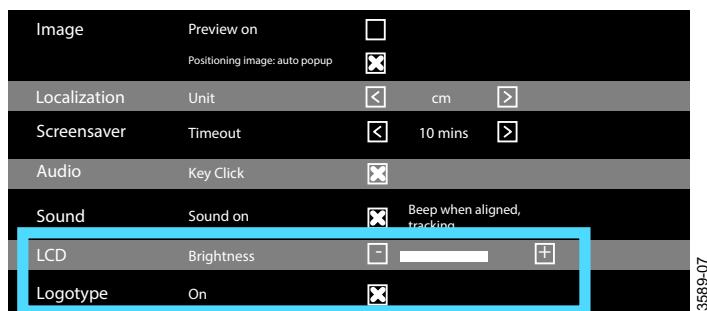

Fig. 3-25 Menu *USER SETTINGS* – tab *SETTINGS*

- Use `LCD` to adjust the display brightness.
- Use `Logotype` to set if the logo shall be shown or not.

### User Settings – Themes

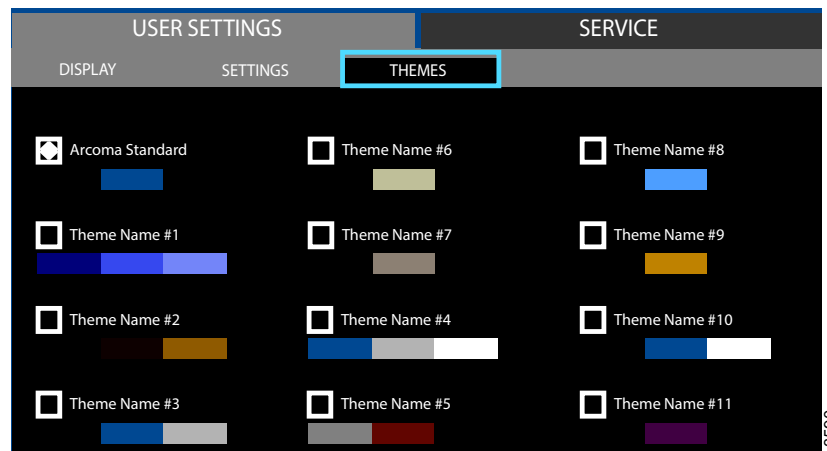

Fig. 3-26 Menu USER SETTINGS – tab Themes

Select a pre-set theme in tab Themes, see Fig. 3-26.

The selection changes the colours of the graphical user interface on the display of the overhead tube crane (OTC) according to the shown colour scheme.

### 3.3.4.2 Service

The Service tag is meant to be used by the service technician.

#### Service – Log

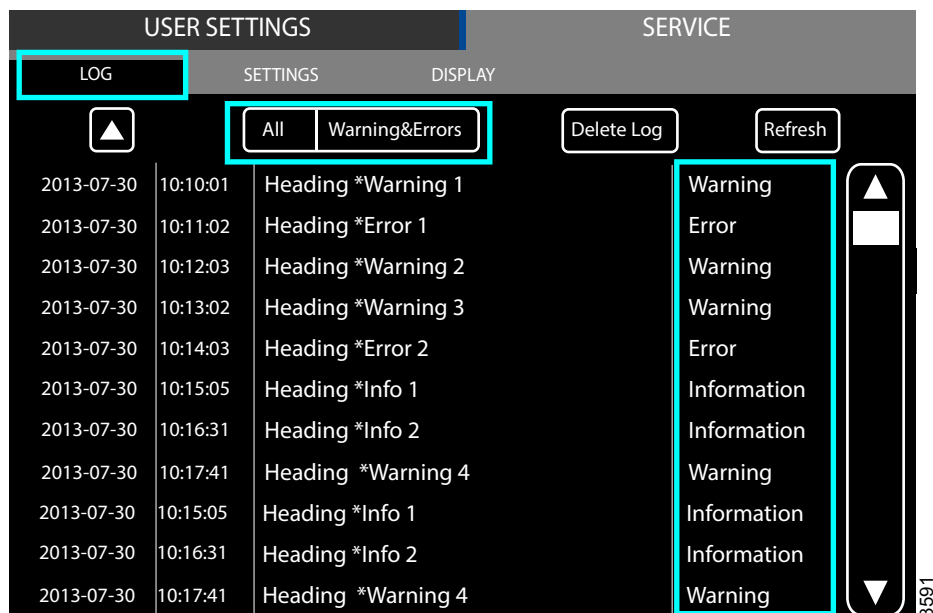

Fig. 3-27 Menu SERVICE – tab LOG

The log file shows warnings, errors and events that have occurred in the system. The log file can be filtered to show all information, All, or just warnings and errors, Warnings & Errors. By selecting Warning, Error, or Information in the right column, more information concerning the issue is shown.

# User Interface

## Display User Interface

---

The log file may be used for troubleshooting.

It is possible for service personnel to delete the log file which can be helpful when fault tracing. The refresh button retrieves the latest events.

### Delete Log File

**Note!**

*This procedure shall only be performed by service personnel.*

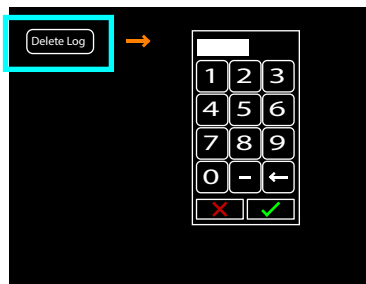

Select **Delete Log** and enter a four digit access code to delete a log file.

Fig. 3-28 Delete log file

### Service – Settings

The Service menu shows system set up and system software versions.

A code is required for access to Settings.

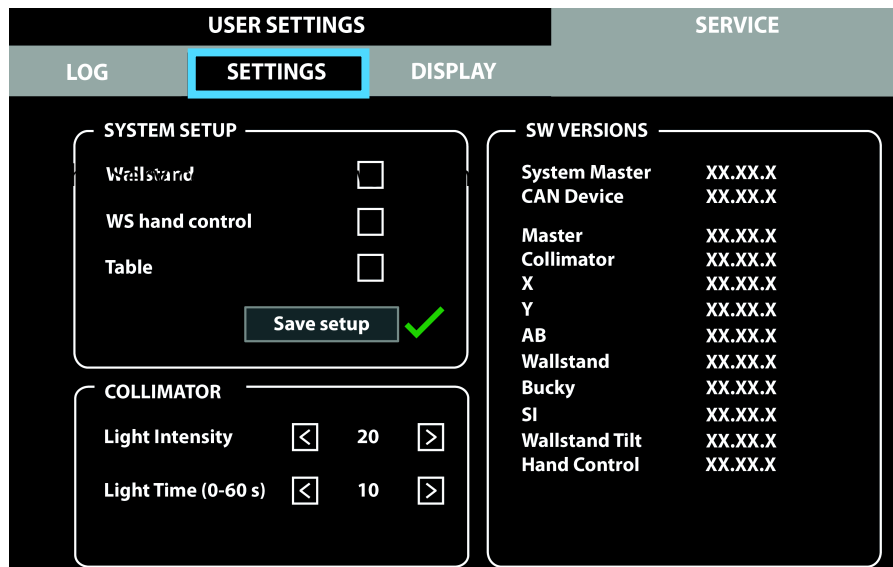

4176

Fig. 3-29 Menu SERVICE – tab SETTINGS



### Service – Display

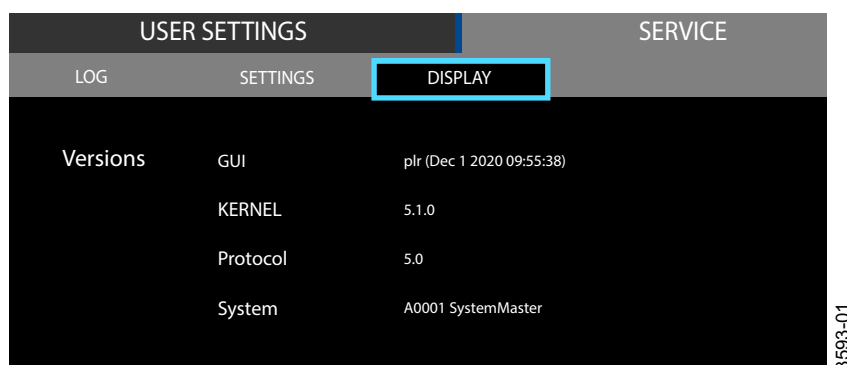

Fig. 3-30 Menu SERVICE – tab DISPLAY

Information of the display software versions.

### 3.3.5 System Mode

The System has a number of different modes. All modes are described below with their special functionalities and features.

Note that depending on the particular System, different modes and actual configurations are available.

- *Free mode*
- *Auto position mode*
- *Wall flexible mode*
- *Table flexible mode*
- *Film tracking mode*
- *Pendulum mode, Table*
- *Stitching mode* (toward the table and wallstand)

#### 3.3.5.1 Free Mode

##### General Description

The *Free mode* is the most basic mode in the System.

The mode holds no special features or functionality. It is intended as a manual mode with a lot of freedom in positioning and exposure, e.g. for emergency examinations or examinations with the patient in a wheel chair or lying in a bed. This mode is available in all Systems.

The distance shown in display for *Free mode* is the distance to the floor.

##### Exposure Validation

Exposure is allowed if the stand is not moving and operating properly (not in an error state).

#### 3.3.5.2 Auto Positioning Mode

##### General Description

The *Auto position mode* functions as the *Free mode* with the added functionality of automatic positioning in the room.

Automatic positions are a number of positions that can be programmed and saved into the System. The stand moves upon activation of the servo button to the programmed position chosen from the imaging unit.

# User Interface

## Display User Interface

---

The mode is intended as a flexible, easy to use mode. The mode can also be used as a parking mode.

The distance (H) shown in display for *Auto position mode* is the distance to the floor.

### **Exposure Validation**

Exposure is allowed if the stand is not moving and operating properly (not in an error state). The chosen position must have been reached successfully.

### **3.3.5.3 Wall Flexible Mode**

#### **General Description**

The *Wall Flexible mode* is intended for examinations toward a wallstand.

The wallstand detector angle is controlled from the APR.

The overhead tube crane moves upon activation of the servo button to the programmed position associated with *Wall mode*. The stand stops at the transport height and waits for a change in position of the wallstand (detector height). When a change in position is detected (the user moves/runs the wallstand up or down) the overhead tube crane moves downward and start tracking the position of the detector.

The SID value is constantly updated as soon as the wallstand/overhead tube crane is moved. It is possible for an operator to change the position so the SID value cannot be calculated or would be incorrect; in those situations the display does not show a SID value.

#### **No Wait**

At the installation of the System it is possible to select, that the overhead tube crane shall not wait for the user to move the wallstand before tracking starts. The overhead tube crane then starts the tracking as soon as it reaches its final position.

### **Exposure Validation**

Exposure is allowed if the stand is not moving, operating properly (not in an error state) and the servo button is activated.

### 3.3.5.4 Table Flexible Mode

#### General Description

The *Table flexible mode* is equal to *Auto positioning mode* with functionality added for tracking the height of the Table (compare with Wall flexible mode). The mode is intended for Table examinations.

The stand moves upon activation of the servo button to the programmed *Table mode* position and starts tracking the Table height, thereby keeping the film focus distance constant. The *Film focus distance* shown in the display is the actual distance to the detector. The Table position in the room is set during the installation of the System.

#### Exposure Validation

Exposure is allowed if the stand is not moving, operating properly (not in an error state) and the servo button is activated. Movement is allowed in X and alpha direction.

### 3.3.5.5 Film Tracking Mode

#### General Description

The *Film Tracking mode* functions as the *Table mode* with added functionality for controlling the position of the detector in one direction. The mode is intended for fast and easy positioning with the X-ray tube always aimed at the center of the detector.

The motorized detector holder moves the detector to the right position. The stand moves upon activation of the servo button to the pre-programmed *Film-tracking position* and start tracking the Table height, thereby keeping the film focus distance constant. The film focus distance shown in the display is the actual distance to the detector. When *Film Tracking mode* is chosen, all buttons except X and alpha-brake buttons are deactivated. The tube stand is operated manually by releasing one or both of the brakes. The position of the detector is changed according to the change in X and or alpha position of the tube. That is the X and alpha positions can be changed independently.

#### Exposure Validation

Exposure is allowed if the stand is not moving, operating properly (not in an error state), the X-ray tube is aimed to the center of the detector and the servo button is activated.

# User Interface

## Display User Interface

---

### 3.3.5.6 Pendulum Mode, Table

#### General Description

The *Pendulum mode* can be seen as a variation of film tracking.

The X-ray tube is always aimed at the center of the detector. The alpha angle of the tube and the position of the detector changes according to the change in X-position of the tube stand. Also *Pendulum mode* incorporates all the functionality of the more simple Table mode. The mode is intended for fast and easy positioning with the X-ray tube always aimed at the center of the detector.

For moving and controlling the position of the detector, a motorized detector holder is required. The stand moves upon activation of the servo button to the programmed position associated with the *Pendulum mode* and start tracking the Table height, thereby keeping the film focus distance constant.

All table handle bar buttons, except (move left) and (move right) buttons, are deactivated when the *Pendulum mode* is activated. The X-position of the stand is controlled by these two buttons and thereby also the detector and the alpha angle of the tube.

#### Exposure Validation

Exposure is allowed if the stand is not moving, operating properly (not in an error state), the X-ray tube is aimed to the center of the detector and the servo button is activated.

### 3.3.5.7 Stitching Mode

#### *Stitching, schematic description*

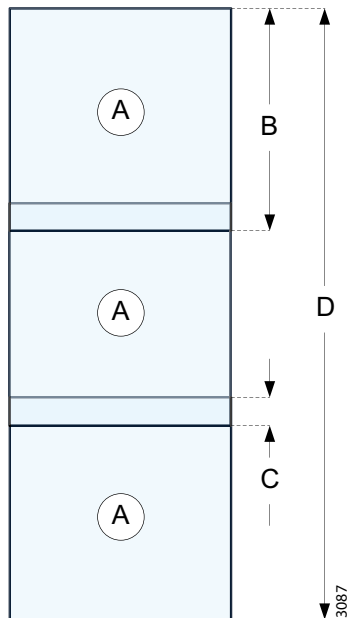

Fig. 3-31 Composite Image

- A Partial Image
- B Partial Image Height
- C Overlap
- D Composite Image Height

Stitching is the process of combining multiple images with overlapping fields of view to produce a larger image.

When imaging long parts of the human body, there is need for an image with extended length. In digital radiography the image size is limited due to the sensitive area of flat-panel detectors. In order to produce a large image, images are assembled from multiple exposures with a small, spatial overlap.

Stitching is possible at both table and wallstand.

# User Interface

## Display User Interface

---

### **Wallstand/TableStitching**

The user must define the area that shall be captured in the stitching sequence.

When choosing *Stitching mode*, new information is present on the manoeuver handle:

- high (left) position
- low (right) position
- total length
- number of exposures

The tube support moves to the pre-defined position for X, Y, Alpha, Beta, and Wallstand (detector holder for TableStitching). Z moves to the position received from the Image system (*SID value for TableStitching*).

To start the stitching procedure, press `Start exam`.

The movement for stitching is:

- From head to foot, for both wallstand and table.

The operator sets the size of the stitching area (the composite image) by positioning the light field.

### **Note!**

---

*A patient protection shall always be used at wallstand examinations when performing stitching examinations.*

---

For detailed information about the stitching operation, see the Operator's Manual.

### **Exposure Validation**

It is only possible to perform an exposure when the System is ready:

- indication light is fixed
- generator is enabled.

The exposure is blocked and the user needs to activate the start button once more if:

- a new parameter setting is received,
- the System is moved out from the start position,
- a collision when moving,
- the patient position removed, or
- the collimator size is changed.

### **3.3.6 Hospital method book**

The Hospital method book is reached by activating the *Hospital method book* button for 1 second.

The Hospital method book is selectable when a method book has been loaded to the display (performed by a service technician).

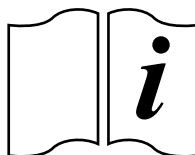

Fig. 3-32 Hospital method book button

### 3.3.7 Selection of Technique Mode

There are three different technique modes available that are selected by pushing the *Technique mode selection* button. The selected mode is highlighted and the pop-up window closes automatically.

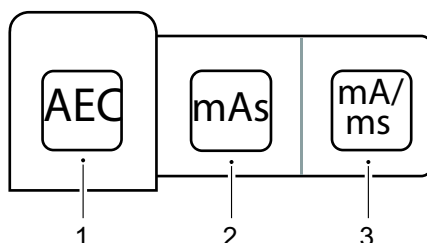

Fig. 3-33 Technique mode selection

1. AEC mode
2. mAs mode
3. mA/ms mode

Depending on what mode is active, different parameters are available. Parameters not available for selection are grayed out, see the *mAs selection* button in **Fig. 3-34**, below.

In *AEC mode*, the value used as back-up value (ms, mAs or fixed) is indicated with the text *AEC Backup*.

#### **CAUTION!**

**To avoid unnecessary radiation, make sure that the AEC back-up values are properly defined.**

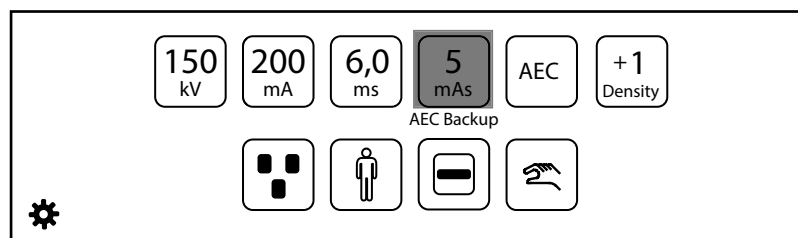

Fig. 3-34 mAs selection button grayed out

For more detailed information about the different technique modes, please see Operator's Manual for Canon single console CXDI NE.

### 3.3.7.1 Selection of Active AEC Field (AEC Mode Only)

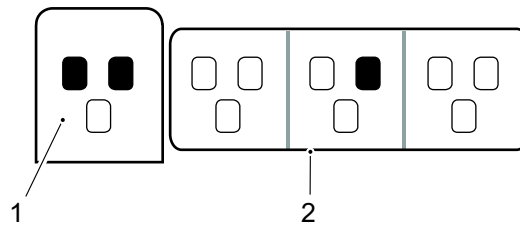

Fig. 3-35 AEC field selection

1. Activated AEC fields
2. Pop-up window for selecting AEC fields

The *AEC field selection* button is available in *AEC mode*.

When selecting the *AEC field* button, a pop-up-window with the different AEC fields appears, see **Fig. 3-35**.

The AEC fields are activated by selecting them in the pop-up window **2** to the right.

All activated AEC fields are shown at **1**.

AEC fields are deactivated by selecting them again in the pop-up window **2**.



### 3.3.8 Patient Size

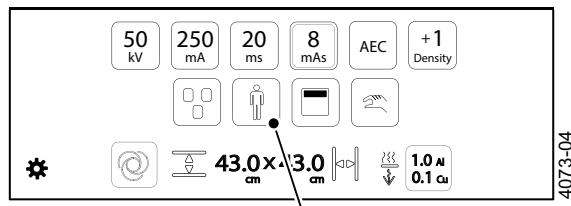

Fig. 3-36 Patient size selection button

The *Patient size setting* is used for a quick setting of the generator parameters to suit the physique of the patient.

Adjust *Patient size* by pressing the *Patient size selection* button, see **Fig. 3-36**. A pop-up window, according to **Fig. 3-37**, opens and shows available patient sizes.

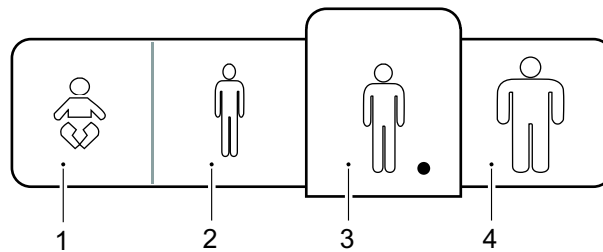

Fig. 3-37 Patient size selection

A Paediatric  
B Small

C Medium  
D Large

Select the desired *Patient size*. The pop-up window automatically closes shortly after the selection.

#### Note!

The generator parameters and the collimator settings (field size and filter) change to the defined values for the new *Patient size*.

If no generator parameters or collimator settings are defined for the new *Patient size* (defined in APR), the current values are kept.

### 3.3.9 Collimator Centering

The collimator light field size can be top or bottom centered against the maximum image area.

This means that the upper border of the collimator light field is aligned with the top of the maximum image area, or that the lower border of the collimator light field is aligned with the bottom of the maximum image area. The stand moves automatically to keep the alignment of the top or bottom of the maximum image area when the collimator light field is increased or decreased.

The functionality of top and bottom centering is only available in *Wall mode* or *Wall Flexible mode*.

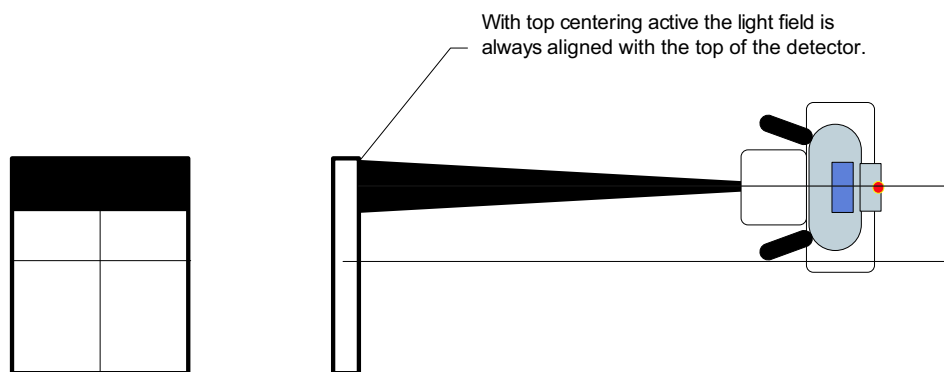

Fig. 3-38 Top and bottom centering of the collimator light field

With top centering active the light field is always aligned with the top of the detector.

The collimator centering is adjusted by pressing the *Collimator centering* button.

A pop-up window according to **Fig. 3-39** appears with the alternatives *Top centering* and *Bottom centering*. Select the desired collimator centering.

The pop-up window closes automatically short after the selection and the light field is accordingly adjusted.

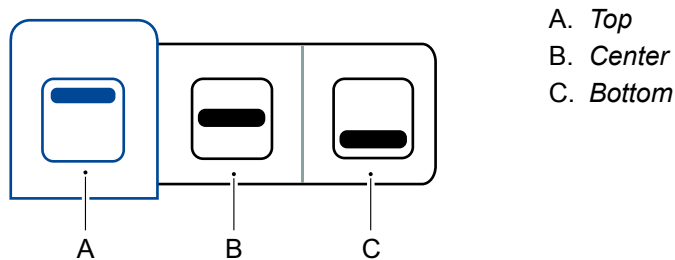

Fig. 3-39 Collimator centering selection

### 3.3.10 Servo State Mode

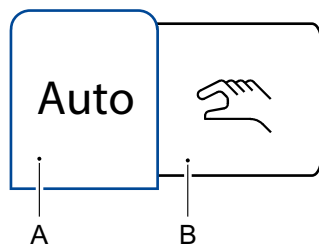

Fig. 3-40 Servo state mode

A Automatic mode

B Manual mode

The Servo state can be either *Automatic mode A* or *Manual mode B*.

A pop-up window according to **Fig. 3-40** appears with two alternatives. When the System is in *Manual mode* all movements are allowed and exposure can be performed in any position, also outside the detector.

For further information about *Manual mode*, see corresponding section.

# User Interface

## Display User Interface

### 3.3.11 Grid Status

The grid status is indicated in the overhead tube crane display and in the Canon NE user interface for guidance. There is also a pop-up window appearing in the Canon NE user interface if grid status needs to be adjusted.

It is possible to perform exposure without adjusting the grid status according to the information in the pop up window. Please note that performing exposure with incorrect grid status might affect the image quality negative.

The grid status is shown in the upper right corner of the Canon NE user interface.

When the correct grid is attached the grid name is written with black letters, see Fig. **Fig. 3-42**.

When a grid is not needed for the examination "Removed" is shown with black letters in the same location, see Fig. **Fig. 3-42**.

When a correction of grid status is needed this is indicated with red text in the Canon NE interface, see detailed description in **Table 3-1**.





Fig. 3-41 User interface. Grid data displayed.



Fig. 3-42 User interface. Grid removed.

Table 3-1 Grid information in OTC display and image system user interface.

Display	Message image system user interface	Description	User Action
	Removed	<b>INSERT GRID</b> Pop up window in the image system user interface guides to insert the correct grid defined for the selected protocol.	Insert grid. Grid shall be used for this examination.
	Example: 180cm_10:1_52 lp/cm	<b>REMOVE THE GRID</b> Pop up window in the image system user interface guides to remove the grid.	Remove the grid. No grid shall be used for this examination.
	Example: 115cm_10:1_52 lp/cm	<b>CHANGE GRID</b> Pop up window in the image system user interface guides to exchange the grid inserted to the requested grid according to the protocol.	Wrong grid inserted (name of the attached grid shown in the image system user interface). Change to the correct grid

# User Interface

## Display User Interface

### 3.3.12 Light Indication

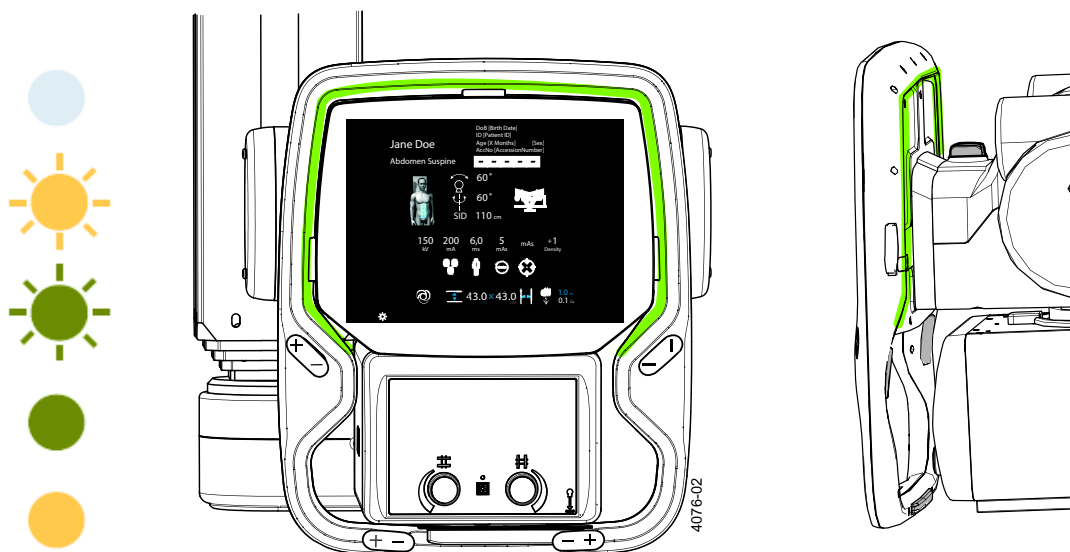

Fig. 3-43 Light indication

There is a light indication available around the overhead tube display.

- No light — Between examinations
- Yellow flashing — Action needed by the user or system is moving
- Green flashing — System is ready for exposure
- Green fixed — Preparation (before exposure)
- Yellow fixed — Exposure

### 3.4 Exposure

**CAUTION!**

**The operator is responsible for validation of the exposure parameters before performing an exposure.**

---

#### 3.4.1 Exposure Hand Control

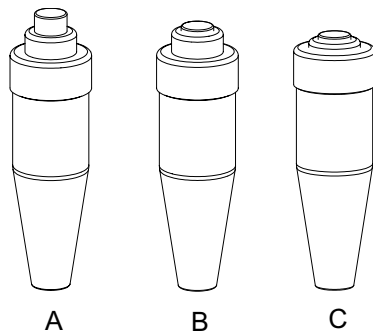

Exposure operator console in

- A. normal position
- B. preparation position
- C. exposure position

Fig. 3-44 Exposure operator console

#### 3.4.2 Exposure Index

After exposure, the Exposure Index (EXI) and Deviation Index (DI) is shown in the image, in order to indicate the dose level. See further description of the indexes below.

The exposure index is a measure of the amount of exposure received by the detector and depends on mAs, the total detector area irradiated respective the beam attenuation. It is indicative of the image quality.

#### 3.4.3 Deviation Index

The deviation index, DI, gives an indication of the dose level used for capturing the image. The DI value compares the current standard EXI with the target EXI.

The target EXI is defined by the user. See Imaging system for further description.

### 3.5 Image System

For information about Image system functions, see the Image System Manual.



### 3.6 Remote Control (option)



#### **WARNING!**

**The System must always be supervised when activated.**

#### **Note!**

The remote control shall only be used inside the examination room.

#### **Note!**

Always mark up the remote controls with, for example, the room number or the system number. Use the enclosed labels to distinguish different system remotes, from each other.

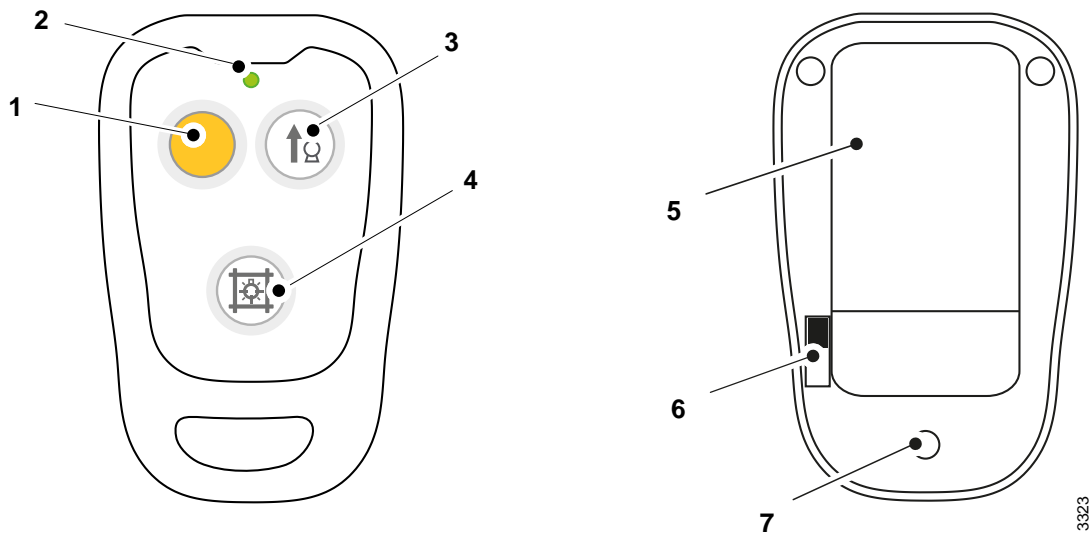

Fig. 3-45 Remote control, front and back

#### **Front**

- 1 Servo button – (yellow)
- 2 Indication diode (green)
- 3 Tube up
- 4 Switch On/Off Collimator light

#### **Back**

- 5 Fastening clip
- 6 On/Off switch
- 7 Battery changing slot

#### **Servo button**

The servo button is yellow with a little peg, making it easy to recognize the button. When activating the yellow servo button, the overhead tube crane moves to auto-position.

# User Interface

## Remote Control (option)

---

### **Indication diode**

The diode shows a green light, when the remote control button is activated. When the diode turns red, the batteries shall be exchanged.

### **Tube up**

When the *Tube up* button is activated, the overhead tube crane moves upward. The movement stops when the button is released or when the highest possible position is reached.

### **Switch On/Off collimator light**

The button turns the X-ray field illumination and linear light localizer on/off.

Automatic switch-off via a time switch.

### **On/Off switch**

There is an On/Off switch for the remote control at the back of the remote control. When the control is switched off, all buttons are disabled.

### **Battery changing slot**

When the indication diode lights red, changing of battery is needed.

The remote control uses 2 LR03, 1.5V, AAA batteries. To change batteries, loosen the 3 screws and open the slot at the back of the remote control.

### **Note!**

---

*The batteries shall be recycled.*

---

### 3.7 Servo Button

When the servo button is activated, the overhead tube crane and wallstand detector (depending on system setup) automatically start positioning (excluding *Free mode*). If the servo button is released, the movement stops and a manual movement of the stand is possible.

When a new protocol is chosen or if the overhead tube crane is manually moved from the position, the overhead tube crane automatically starts moving to a predefined position when the servo button is activated.

The servo button is available on the external servo button module, the wallstand hand control, and on the remote control (option). The system status is indicated by indication light on the external servo module and at the overhead tube crane.

#### 3.7.1 External Servo Button Module

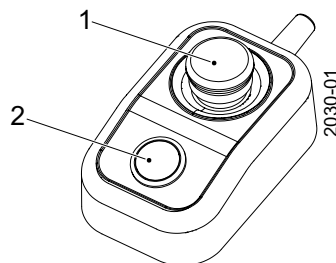

The external servo button module has a servo button and an emergency stop. The servo button is equipped with an indication light showing the system status. See **Fig. 3-46**.

Fig. 3-46 External servo button module

1. Emergency stop
2. Servo button and Indication light

#### 3.7.2 Indication Light



#### **WARNING!**

---

**Due to the squeezing hazard, motorized movements are only allowed if patient and System are observed by personnel.**

---

The Indicator light has 3 different modes:

- *Fixed light* - The System is in position and ready for exposure. Supervision of the patient and System is required.
- *Flashing light* - Attention. The System is performing an action, for instance manoeuvring to start position or waiting for action.
- *No light* - the chosen mode is not activated. No light is shown in *Free mode*.

See also **3.3.12 Light Indication**.

#### 3.7.3 DAP

If a DAP meter is included in the System, the Dose Area Product is presented in the Imaging system.

Checks and settings can be done by the service software, see '*Installation and Service Manual*', Chapter 5, *Installation*.

# User Interface

## Table Control elements

---

### 3.8 Table Control elements

#### 3.8.1 Directions of Movement

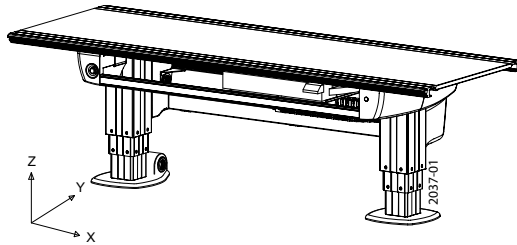

Fig. 3-47 Directions of movement, Table displayed from the front

Fig. 3-47 shows the directions of the table movement.

- Z Vertical movement
- Y Lateral movement
- X Longitudinal movement

#### 3.8.2 Power Indication

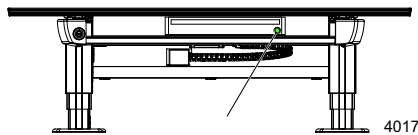

Fig. 3-48 Power indication light

The green light indicates that the System is active.

#### 3.8.3 Foot Control, Table X/Y/Z (option)

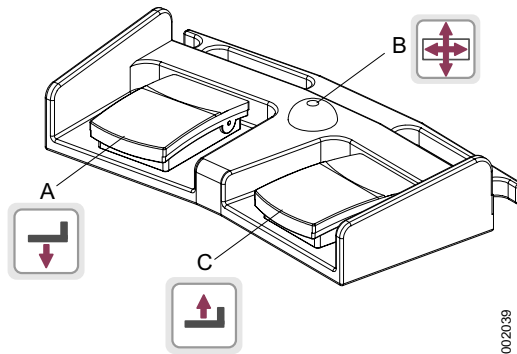

Fig. 3-49 Foot control

- A Z movement down
- B Unlock table top brakes (X/Y)
- C Z movement up

The foot control can be used for adjusting the table top height and for releasing the floating table top.

Consider the working area when the table top is manoeuvred.

##### 3.8.3.1 How to Manoeuvre

- A. Press button to move the table top downward.
- B. Press the button to release the brakes on the table top, Y and X. On activation, the table top can be moved manually.  
When the release button is activated, the collimator light is lit.
- C. Press button to move the table top upward.

### 3.8.4 Foot Control, Wireless (option)

#### **CAUTION!**

---

**Make sure that the correct control is activated, as there is one foot control for the table and one for the wall stand.**

---

The foot control can be used for adjusting the table top height and for releasing the floating table top.

Consider the working area when the table top is manoeuvred.

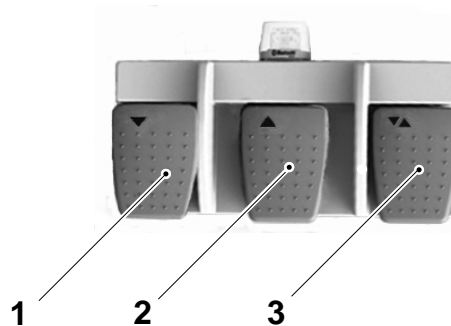



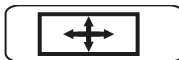

Fig. 3-50 Wireless foot control.

1. Z movement down 
2. Z movement up 
3. Release pedal:  
 Unlocks wall stand detector brake. Manual movement is possible.  
 Unlocks table top. Manual movement is possible, table top is floating.

#### 3.8.4.1 How to Manoeuvre

1. Press pedal to move downward.
2. Press pedal to move upward.
3. Press the pedal to release the brakes. On activation, the table top or the wall stand detector holder, can be moved manually.

When the release pedal is activated, the collimator light is lit.

#### **Note!**

---

*The foot control must not be used outside the examination room.*

---

The device has no applied parts and should not be accessible to patients.

#### 3.8.4.2 Battery

The yellow battery indication LED begins to flash once every two seconds, when the remaining battery capacity is approximately 1 week of constant use, or 168 hours. It then changes to 2 flashes per second when the capacity has been reduced to approximately 2 days, or 48 hours.

# User Interface

## Table Control elements

---

### 3.8.5 XY Foot Control, Strip Type (Option)

Press and hold the foot control strip type (1) to release the brakes (X, Y) on the table top (2).  
When activated, the table top can be moved manually (floating table top).

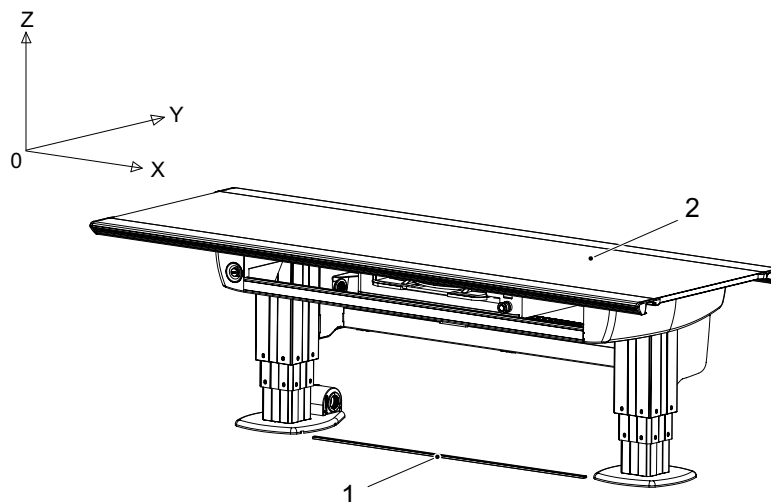

Fig. 3-51 Foot control strip type

1. XY foot control strip type (option)

2. Table top (X/Y)

### 3.8.6 Table Hand Control

Beside the functions for moving the table top, the hand control also has functions for; moving the imaging unit and performing a pendulum movement.

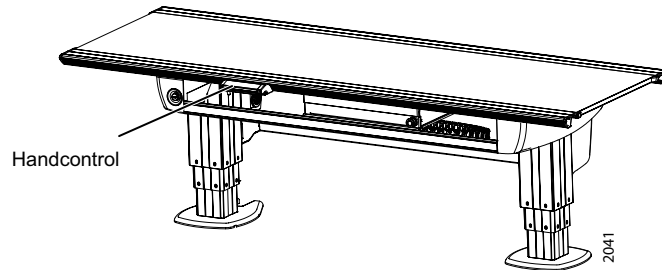

Fig. 3-52 Table hand control location

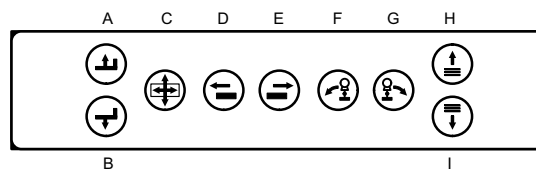

Fig. 3-53 Table hand control

#### 3.8.6.1 How to Manoeuvre

- A. Press button to move the table top upward.
- B. Press button to move the table top downward.
- C. Press the button to release the brakes on the table top, Y and X. When activated, the table top can be moved manually.
- D. Drive motorized image receptor holder to left.
- E. Drive motorized image receptor holder to right.
- F. Move the overhead tube crane to the left in *Pendulum mode*.
- G. Move the overhead tube crane to the right in *Pendulum mode*.
- H. Not used.
- I. Not used.

# User Interface

## Table Control elements

---

### 3.8.7 Moving Table Top

To manually move the table top, release the brakes and use the hand grip rails **A** located at the long sides of the table top.

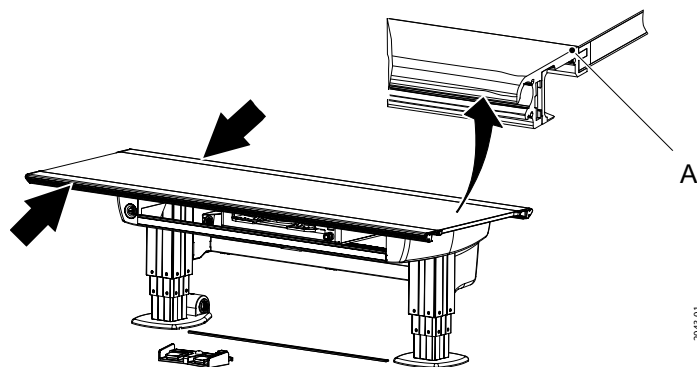

Fig. 3-54 Hand grip rail A, Table

Fig. 3-47 shows the directions of the table movement.

### 3.8.8 Vertical Travel Safety (option)

The Table may, as an option, be equipped with a vertical travel safety system that protects the table top. If a collision is detected and the force exceeds 20 kg, all movements are stopped.



### 3.8.9 Attach/Remove Accessories

Accessories are attached and removed as shown in the figures below. This instruction is valid for all accessories attached to the table top.

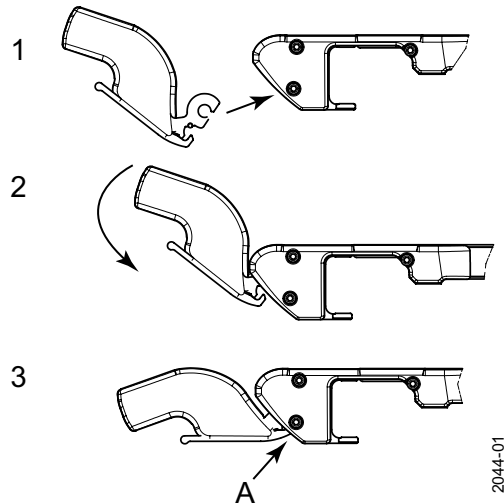

- To attach:
  1. Insert the accessory.
  2. Rotate it downwards.
  3. Click to attach at **A**.

Fig. 3-55 Attach accessories

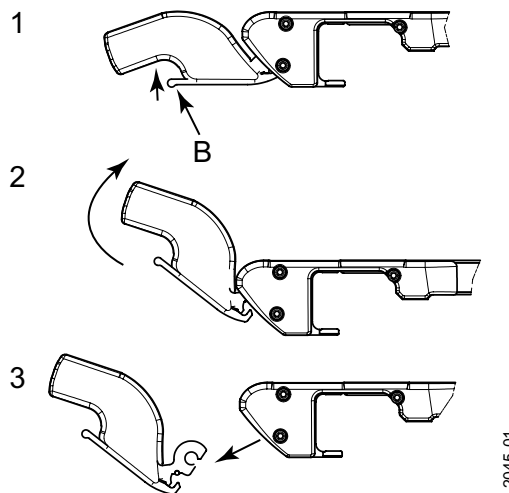

- To remove:
  1. Press on the accessory at **B**.
  2. Rotate it upward.
  3. Remove the accessory.

Fig. 3-56 Remove accessories

### 3.8.10 Motorized Imaging Unit Movement

The imaging unit can be moved in X direction motorized. The motorized movement is maneuvered from the table hand control, see **Fig. 1-4**. The function can synchronize the imaging unit and follow the movement of the ceiling unit.

#### 3.8.10.1 Synchronization Function

In Auto position mode and in Table flexible mode, the detector holder may be moved in X-direction using the motor (via the table handle or manually by activating the green button at the detector holder). There is no synchronization between the tube and the table detector.

In Film tracking and Pendulum mode the detector holder may be moved manually in X-direction. If this is done, the servo button is deactivated and exposure is no longer possible. To return to an activated servo button, the detector holder shall be moved to the correct position. The correct position is indicated by the lighting of the green detector holder button.

**Note!** \_\_\_\_\_

*It is the user's responsibility to verify that the detector is in position at exposure.*

---

### 3.9 Wallstand Control Elements

#### 3.9.1 Wallstand Controls

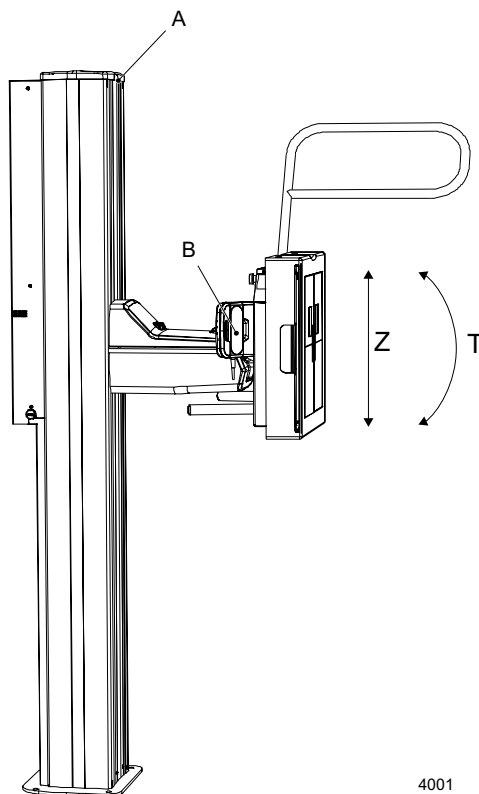

Fig. 3-57 Wallstand, direction of movement

*Z* Vertical movement

*T* Tilting movement

*A* Light indication (lit when the wallstand is selected as a work station)

*B* Hand control:

*Adjustment of the automatic collimator, vertical movement of the detector, rotation of the detector and activation of pendulum mode.*

The wallstand detector is tilted by activation of the hand control. The detector can be tilted -20 to + 90° .

# User Interface

## Wallstand Control Elements

### 3.9.1.1 Wallstand Hand Control Unit

#### Hand Control

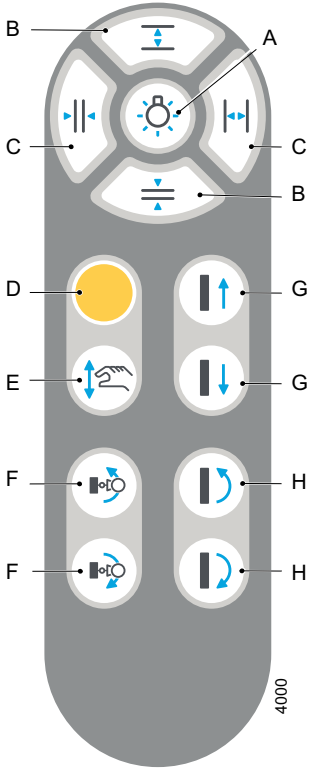

- A. Collimator light on/off
- B. Adjustment height collimation
- C. Adjustment width collimation
- D. Servo button, see 3.7
- E. Break release for manual movement of detector
- F. Pendulum mode wallstand
- G. Detector up/down, Motorized
- H. Detector tilt and overhead tube crane tracking, -20 to 90°

Fig. 3-58 Hand control

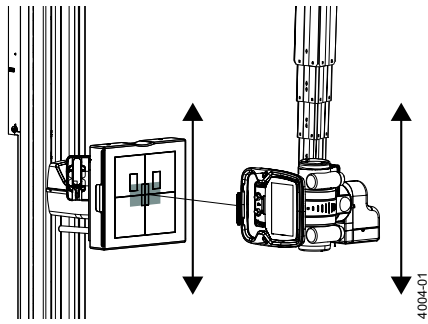

Fig. 3-59 Up/down

Up/down

- Button G, Motorized  
Overhead tube crane tracking wallstand detector when auto-position active
- Button E, Manual

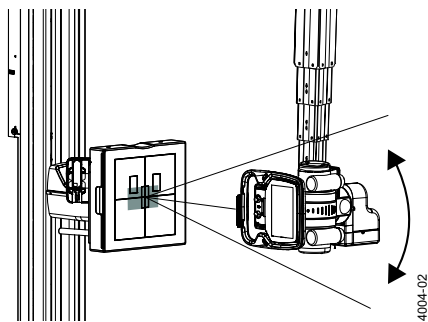

Fig. 3-60 Pendulum mode

Pendulum mode wallstand

- Button F  
The overhead tube crane performs a pendulum movement in order to find correct angulation of the central X-ray

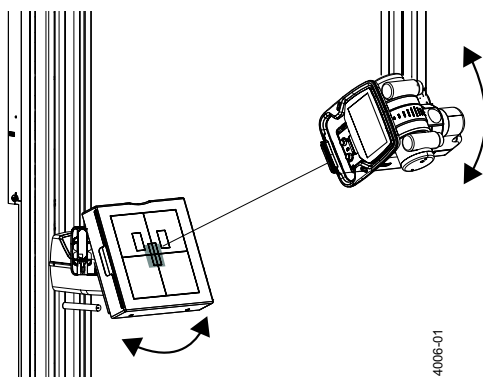

Fig. 3-61 Tilting

Tilting -20° to 90°

- Button H, Motorized Tilt  
Overhead tube crane tracking wallstand detector when auto-position active
- Button E, Manual

**Note!**

*Armrest has to be removed to allow tilt movement.*

---

### 3.9.1.2 Light Indication (A)

The selected Workstation is indicated in the imaging system and with a green light on the wallstand.

# User Interface

## Wallstand Control Elements

---

### 3.9.1.3 Wallstand Foot Control for Vertical Movement

The wallstand with motorized vertical movement is maneuvered from the foot control. The foot control is a control unit for wallstand with motorized vertical movement.

Consider the working area when the wallstand detector is maneuvered.

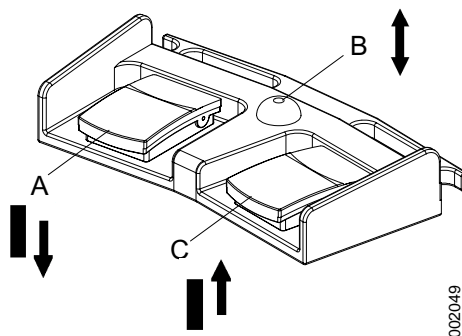

Fig. 3-62 Wallstand foot control manoeuvring

- A Z movement down.
- B Brake release manual movement
- C Z movement up

#### **How to Manoeuvre**

- A. Press the pedal to move the detector downward.
- B. Press the pedal to release the brakes. When activated, the detector can be moved manually.
- C. Press the pedal to move the detector upward.

## 4 Operating the System



### **WARNING!**

*The operator must always have supervision of the System.*

### 4.1 Turn On The System

The system is ready for examination within two minutes after the system has been turned on.

- Before starting the system, check that the emergency stop is not activated.

When the system starts up, light indications and displays are lit.

- Perform the following procedure when starting up the X-ray system:

1. Press the power [ON] button (A) on the mini console.

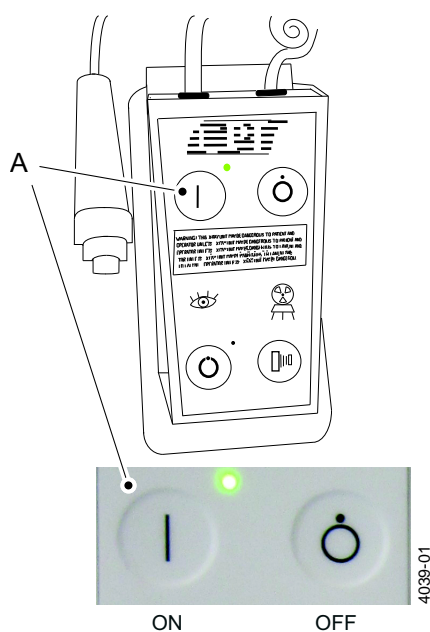

Fig. 4-1 Power on button – mini console

# Operating the System

## Turn On The System

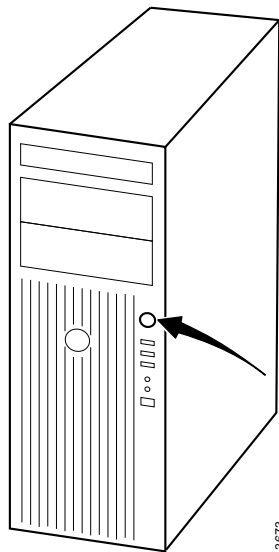

Fig. 4-2 Power button – image control unit

2. Press the power button on the computer.
3. Start the display.

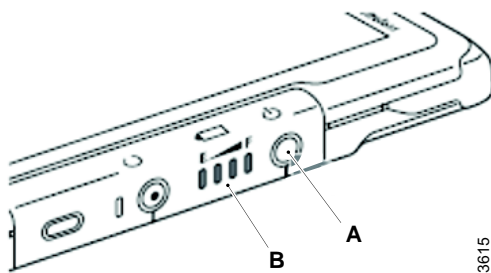

Fig. 4-3

4. Start the wireless detector (option), press the power button (A).  
The power-LED (B) lights with a fixed light.



Fig. 4-4

5. Log in on the computer.
6. Type user name and password, press Log in.

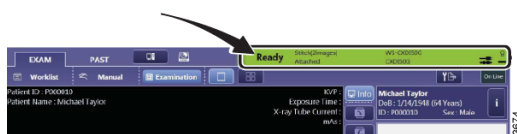

Fig. 4-5

7. Confirm that the image system has started normally by checking the status icons.



### 4.2 Turn Off The System

*Note!*

Wait for two minutes or longer after the examination is completed before turning OFF the power.

1. Move the overhead tube crane to a parking position, for example over the table.
2. Turn off the image system  3611.

Select  3612.

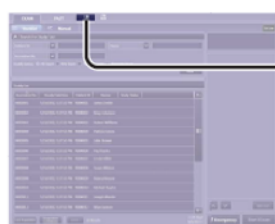

[EXAM > Worklist] screen

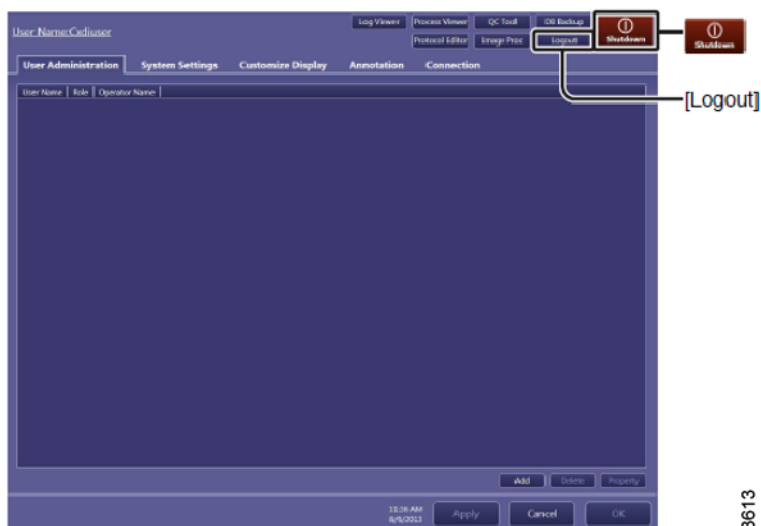

Fig. 4-6



Fig. 4-7 Shut down Confirmation Dialog Box

# Operating the System

## Turn Off The System

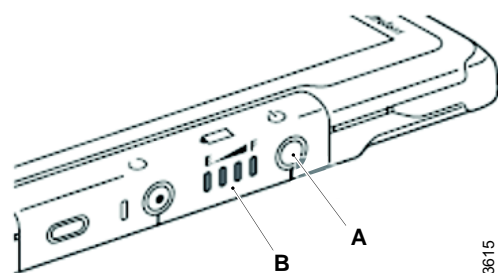
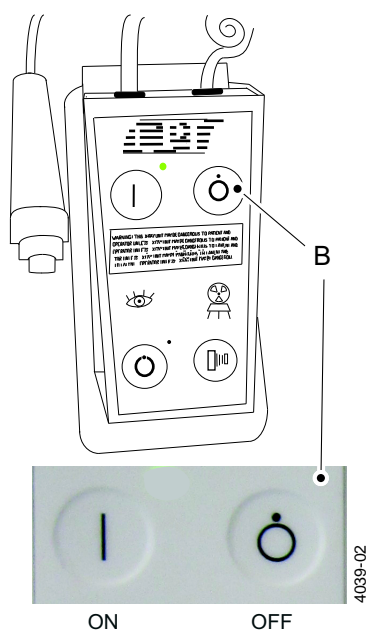

Fig. 4-8

3615

3. Turn off the wireless detector (A).



4. Press the power [OFF] button (B) on the mini console.

It is possible to turn off the power to the X-ray system while the power to the image system is still on.

### 4.3 Perform Examination

#### 4.3.1 Select Patient



Fig. 4-9 Select Worklist

1. Select Exam and Worklist.
2. Sort the list in Search For Study List and select patient.

# Operating the System

## Perform Examination

### 4.3.2 Start Examination

1. Select Start Exam.

Predefined protocols are activated automatically.

Patient data can also be added manually, see Canon Operation Manual.

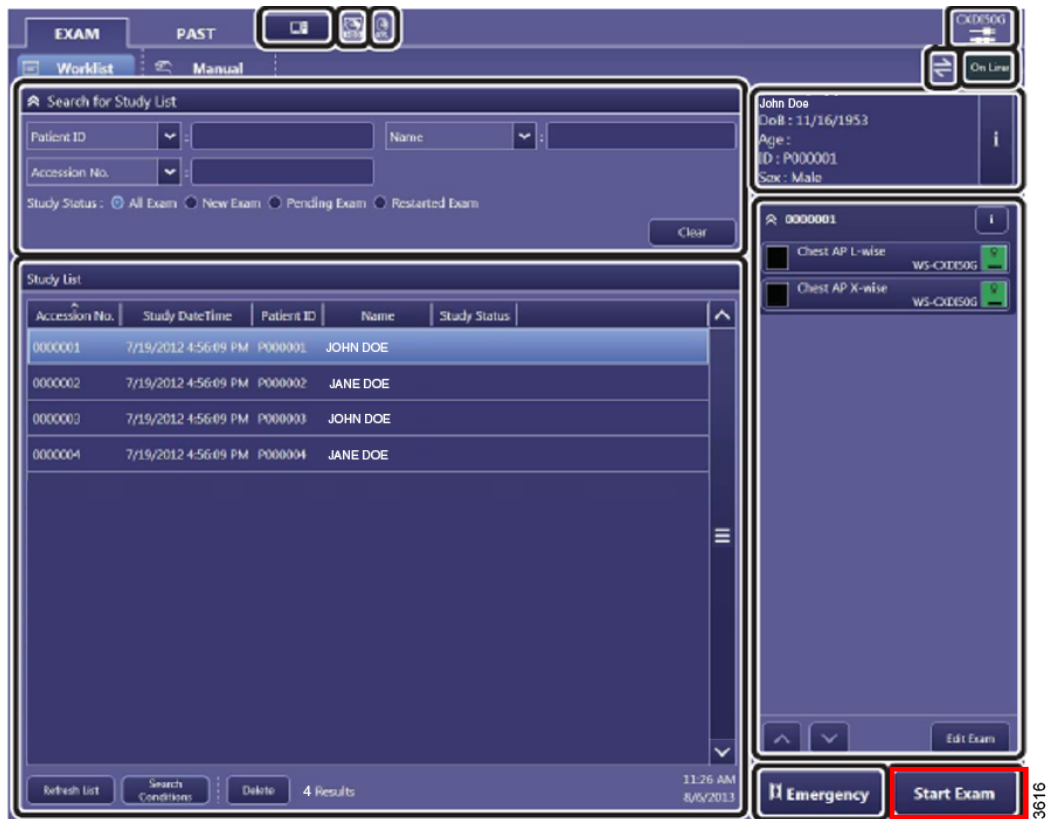

Fig. 4-10

The indication light is lit on the selected workstation.

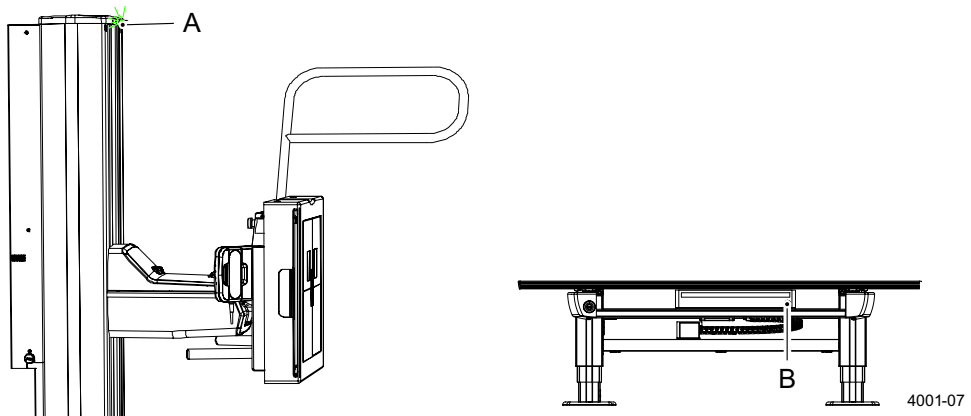

Fig. 4-11 Lights

A Wall stand indication light

B Table indication light

### 4.3.3 Position The System

1. Activate the servo button to position the system.

The servo button is activated on the console, the remote control, or wall stand hand control.

The indication light around the display on the overhead tube crane indicates with a green flashing light that the system reached correct position.

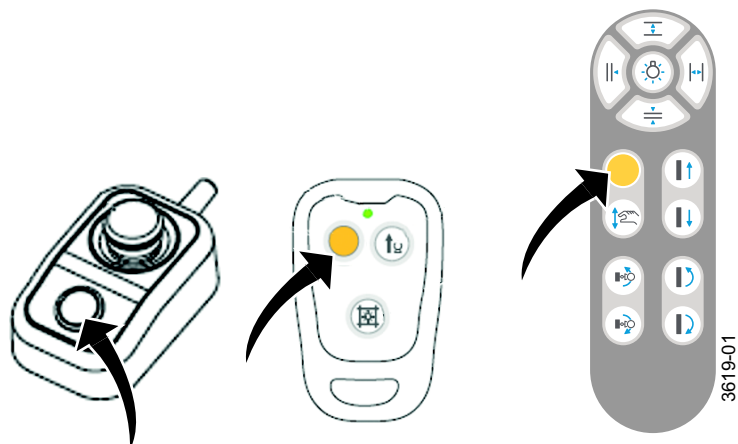

Fig. 4-12 Activate servo button

### 4.3.4 Adjust Position And Collimator For Chosen Examination And Patient

Adjust the position of the overhead tube crane, table top or wall stand according to:

- **3.1.1 Direction of Movement, Page 45**
- **3.8 Table Control elements, Page 80**
- **3.9 Wallstand Control Elements, Page 87**

The light field should be reduced to the examination area. Adjust the collimator according to:

- **3.2 Automatic Collimator Control, Page 47**

# Operating the System

## Perform Examination

---

### 4.3.5 Exposure



**WARNING!**

*Check that the settings of the SID (Source Image Distance) are accurate before the exposure.*

---



**WARNING!**

*Check that the selected workstation (wallstand, table) is connected and linked properly at the Examination Check screen of the image system before the exposure.*

---



**WARNING!**

*Check that the X-ray tube is set at correct position before the exposure.*

---

**CAUTION!**

*It is the responsibility of the user to ensure that the X-ray field is within the active detector area when exposing.*

---

**CAUTION!**

*Materials located in the X-ray beam may cause adverse image effects.*

---

**Note!**

*The operator is responsible for verifying the exposure parameters before exposure.*

---

- Check that the examination conditions are displayed on the image system without failure. Exposures are done using either the hand control or the prep. and X-ray buttons on the operator console.

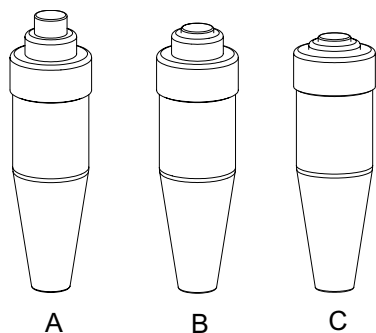

Exposure operator console in

- A. normal position
- B. preparation position
- C. exposure position

Fig. 4-13 Exposure operator console

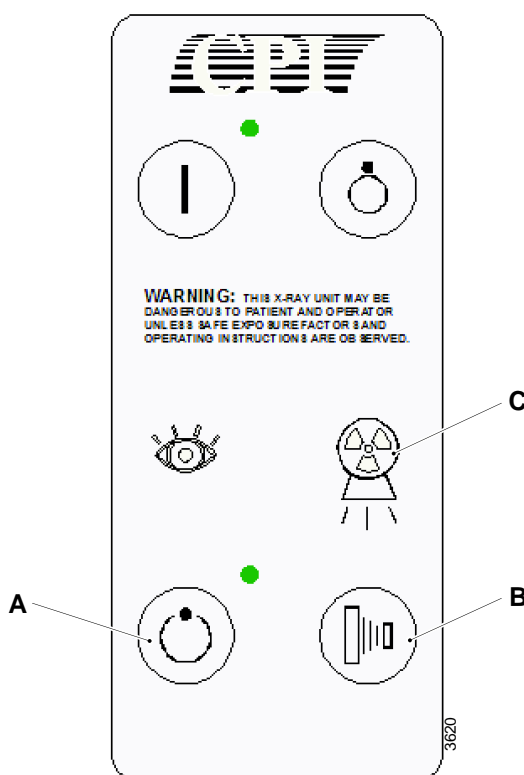

Exposure operator console:

- A. preparation exposure
- B. exposure position
- C. light indicating exposure

Fig. 4-14 Operator console

### 4.3.6 Review Image

- If the image is correct, select **End Exam** or continue the examination if more images are planned.
- If the image is not correct, select **Retake**.
- Type reject reason and retake image.

# Operating the System

## Perform Examination

### 4.3.7 Change Work Space

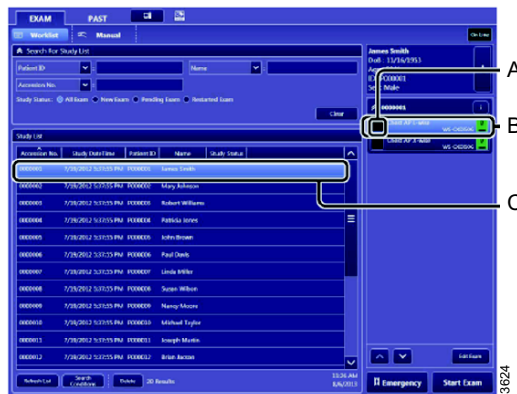

Fig. 4-15 Protocol

1. Select [Protocol].

- A. *Thumbnail*
- B. *Protocol*
- C. *Highlighted selected study order*

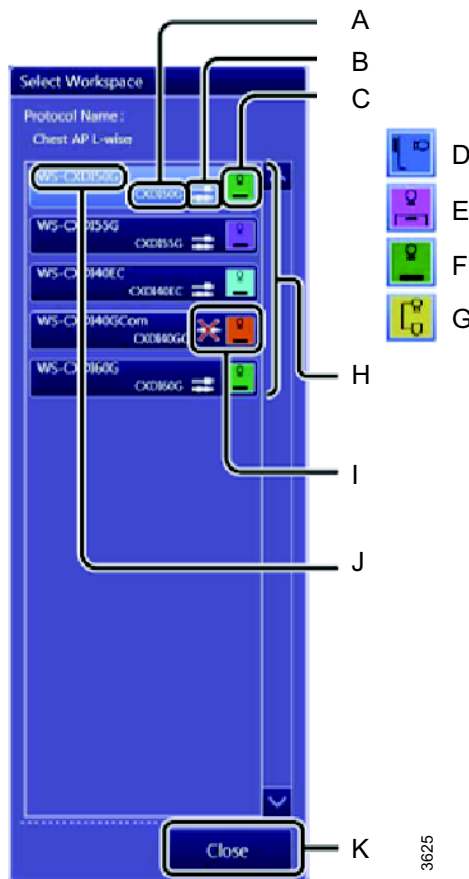

Fig. 4-16 Detector or workspace

2. Select detector or workspace.

- A. *Detector name*
- B. *Detector connection information*
- C. *Patient posture (detector setup)*
- D. *Stand*
- E. *Table*
- F. *Cassette*
- G. *Universal*
- H. *Available workspaces*
- I. *Incomplete detector connection or turned off power box*
- J. *Workspace name*
- K. *Close*



### 4.3.8 Basic Exposure Error Handling

Exposure not possible	Check	Measure
The small detector is selected (Green)	Is the small detector in the docking station?	Remove the small detector from the docking station.
Table examination	If the table is equipped with a wireless detector and charging the detector in the holder - check if the connector is correctly connected to the detector.	Connect the connector correctly to the wireless detector.
Table or wallstand	Is the indication light lit (yellow LED in the control room or green light on the overhead tube crane)?	Position the system correct by pressing the servo button on the remote control, the operators console or on the overhead tube crane.  or Change from Auto to Manual on the overhead tube crane display if the patient/light field is in position (and you don't want to reposition the overhead tube crane).
Table examination	Is the detector in the table detector holder?	Place the detector in the table detector holder, make sure to connect the connector correctly.
Wallstand examination	Is the detector in the wallstand detector holder?	Place the detector in the wallstand detector holder, make sure to connect the connector correctly.

# Operating the System

## Movement Short-Cut Zones

---

### 4.4 Movement Short-Cut Zones

A short-cut movement is defined as, when the overhead tube crane moves directly to the intended position, without first moving up into the transport interval zone.

Movement short-cut zones are defined as rectangular cubes for both the table and the wallstand. (Short-cut zones can be defined by a service technician)

To perform a short-cut movement, the following conditions must be fulfilled:

- The System shall be positioned above the table, or at the specified short-cut zone in front of the wallstand.
- At least one of the overhead tube crane corners must be inside the short-cut zone at the start of the movement.

Outside these short-cut zones, the overhead tube crane first moves in Z direction, to the transport interval zone, before moving to position.

#### 4.4.1 Wallstand Short-Cut Zone

The wallstand short-cut zone is defined in front of the wallstand.

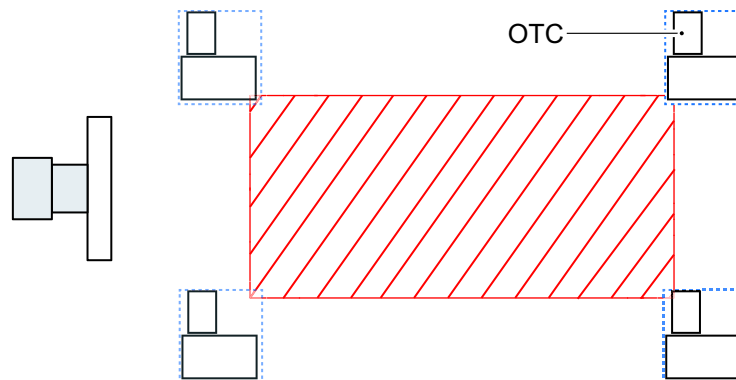

Fig. 4-17 Wallstand short-cut zone

#### 4.4.2 Table Short-Cut Zone

The Table short-cut zone is defined above the table top.

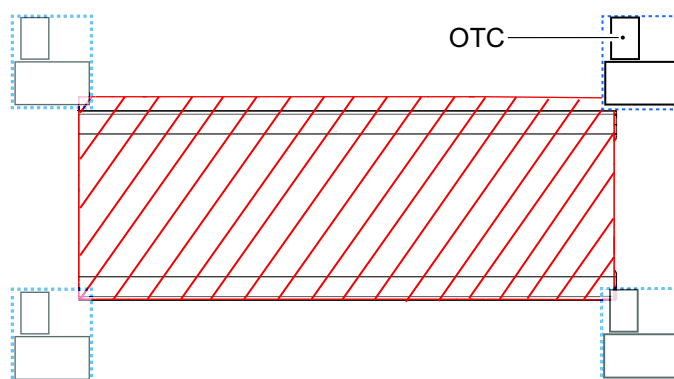

Fig. 4-18 Table short-cut zone

### 4.5 Transport Interval Zone

Outside the short-cut zones, movements between auto-positions are performed in a defined transport interval zone. The upper and lower limits are defined at System installation.

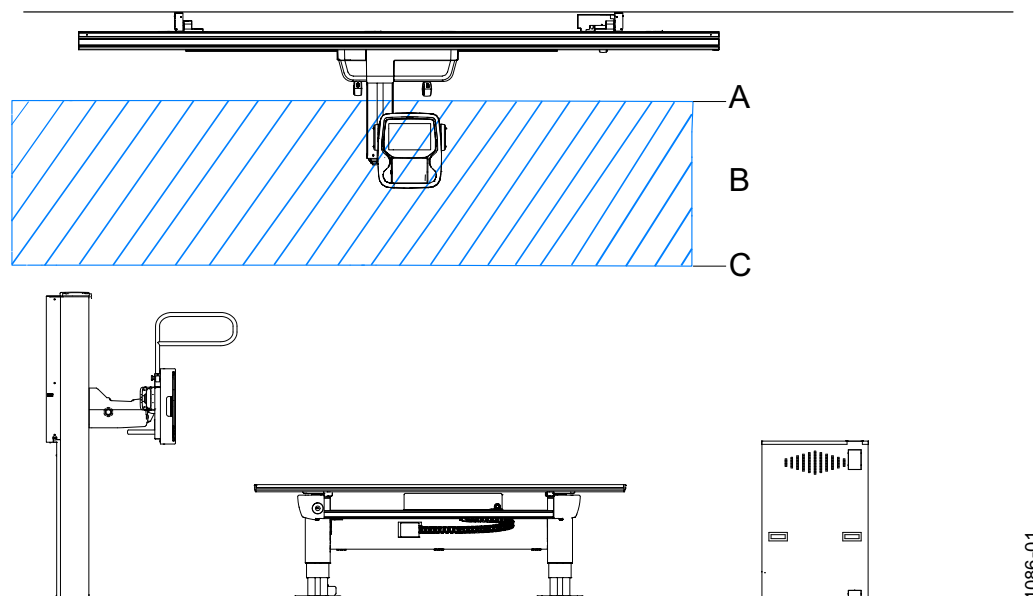

Fig. 4-19

- A Max.
- B Transport interval zone
- C Min.

When moving between positions outside the short-cut zones, the overhead tube crane first moves to the transport interval zone.

Inside the transport interval zone the overhead tube crane moves horizontally until it reaches the intended X, Y-position.

Then the overhead tube crane moves vertically to the intended Z-position.

# Operating the System

## Manual Mode

---

### 4.6 Manual Mode

#### **CAUTION!**

**Be aware that there is no tracking between the x-ray tube and the detector when the System is in Manual mode. Therefore, take extra care that the x-ray beam is within the active area of the detector before performing an exposure.**

---

The System can be set to *Manual mode* from the display. In *Manual mode*, it is possible to move the System manually in the room and perform exposure. In *Manual mode* no tracking is performed. The *Manual mode* can be selected when the System is in one of the following modes:

- *WallFlexible*
- *TableFlexible*
- *FilmTracking*
- *Pendulum table*

#### 4.6.1 Activation of Manual Mode

The servo state can be either *Automatic mode* or *Manual mode*. A pop-up window according to **Fig. 4-20**, is appear with the two alternatives. When the System is in *Manual mode* all movements are allowed and exposure can be performed in any position.



Fig. 4-20 Servo state selection pop-up window

The *Manual mode* is activated by pressing the *Servo state*, see **Fig. 4-20**. If the System is in *TableFlexible*, *FilmTracking* or *Pendulum mode*, the table and the overhead tube crane is shown without connection when *Manual mode* is selected. In the same way, the wallstand is shown without connection to the overhead tube crane in *Manual mode*, see **Fig. 4-21**

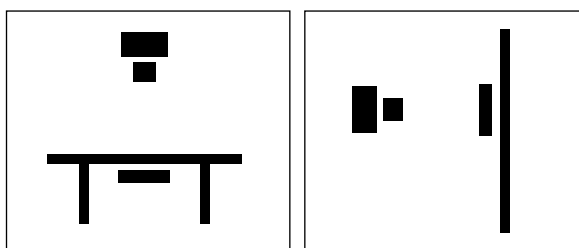

Fig. 4-21 Wallstand and Table shown without connection to the overhead tube crane in Manual mode

### 4.6.1.1 Deactivation of Manual Mode

The *Manual mode* is deactivated by selecting a new APR with a different auto-position. Deactivation is also done by changing to *Automatic mode*.

If the same patient is examined and an APR with the same auto-position is selected, the *Manual mode* is kept.

### 4.6.1.2 Restrictions in Manual Mode

In *Manual mode* the shown SID value is based on the assumption that the detector is positioned in the same way as it should have been in an active servo mode. Note that the SID value is not able to be calculated in some positions. No SID value is shown if the System is not in an active servo mode when *Manual mode* is activated.

Tracking or other mode movements are not possible when *Manual mode* is active.

# Operating the System

## Free Examination Procedures

---

### 4.7 Free Examination Procedures

#### 4.7.1 Free Mode

##### 4.7.1.1 General

The *Free mode* is designed for emergency examinations. The servo button cannot be activated in *Free mode*, consequently no automatic movement is available.

##### 4.7.1.2 Flow of Operation

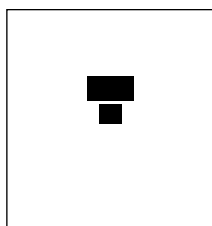

Select a *Free mode* examination.

The System display shows the following, see **Fig. 4-22**.

*Fig. 4-22 Free mode display*

- The stand shows H, distance to the floor.
- All movements are available.

##### 4.7.1.3 Exposure

Exposure is possible when the overhead tube crane is not moving.

*Note!* \_\_\_\_\_

*The overhead tube crane enters automatically the "Free mode" at start-up.*

---

### 4.7.2 Auto Position Mode

#### 4.7.2.1 General

The *Auto position mode* is designed for emergency examinations or examination with a mobile detector.

#### 4.7.2.2 Pre-defined Auto Positions

When the auto position mode is selected, the overhead tube crane is go to a predefined position in the room.

### 4.7.2.3 Flow of Operation

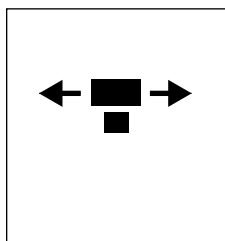

Select an *Auto position mode* examination.

The System display shows, see **Fig. 4-23**.

*Fig. 4-23 Auto position mode display*

- The overhead tube crane shows “H”, distance to the floor.
- Activate the mode by pressing the servo button.
- When auto-positioning to a wallstand, the wallstand detector unit moves into a basic position.
- The overhead tube crane moves automatically to its programmed position.
- The servo mode button light indication is switched off.

All movements are available.

### 4.7.2.4 Exposure

Exposure is possible when the overhead tube crane is not moving.

### 4.8 X-ray Table Examination Procedures

#### 4.8.1 Table Flexible Mode

##### 4.8.1.1 General

The *Table Flexible mode* is designed for examinations with the detector placed on the table top.

The overhead tube crane can be moved freely in all directions. When the height of the table top is adjusted, the overhead tube crane is track the height of the table top in order to keep the SID constant.

##### 4.8.1.2 Flow of Operation

Select a *Table Flexible mode* examination.

The System display is show the following.

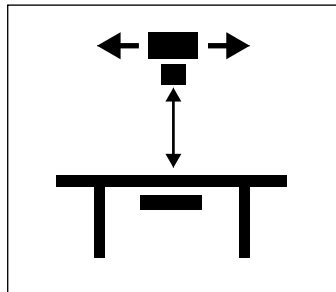

Fig. 4-24 *Table Flexible mode display*

- The SID is displayed.

Activate the mode by pressing the servo button.

- The overhead tube crane moves automatically to its programmed position.
- The overhead tube crane moves to the programmed SID.
- Servo mode indication light fixed.

Adjust the table height.

- The overhead tube crane follows the Table to maintain the programmed SID.

Adjust the tube position.

- The mode is stay activated (detector holder is not follow).
- Move the imaging unit manually, if needed, to assure that the x-ray field is inside the boundaries of the detector.

##### 4.8.1.3 Exposure

Exposure is possible when the overhead tube crane is not moving, and the servo mode indication light is fixed.

**Note!** \_\_\_\_\_

*In "Table Flexible mode" examinations exposure is possible outside the imaging unit.*

*The imaging unit does not follow the overhead tube crane.*

---



### 4.8.2 Film Tracking Mode

#### 4.8.2.1 General

The *Film Tracking mode* is designed for examinations of patients lying on the Table.

#### 4.8.2.2 Flow of Operation

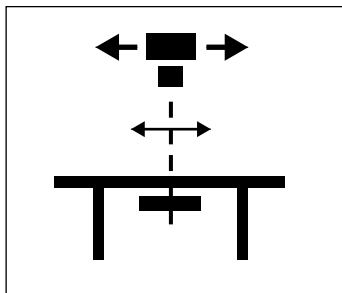

Select a *Film Tracking mode* examination.

The System display shows, see **Fig. 4-25**.

*Fig. 4-25 Film tracking mode display*

- The SID is displayed.

Activate the mode by pressing the servo button.

- The overhead tube crane moves automatically to its programmed position.
- The overhead tube crane moves to the programmed SID.
- Servo mode indication light fixed.

Adjust the table height.

- The overhead tube crane follows the Table to maintain the programmed SID.

Press the brake release button.

Move the overhead tube crane lengthwise the Table.

- The imaging unit follows the movement to stay aligned with the tube.

Press the button to deactivate the alpha brake.

Turn the tube in alpha direction.

- The imaging unit follows the movement to stay aligned with the tube.
- The SID value can be adjusted by moving the overhead tube crane, then all moving is performed with the new SID.

#### 4.8.2.3 Exposure

Exposure is possible when the overhead tube crane is not moving, and the servo mode indication light is fixed, and the x-ray beam covers the image unit

# Operating the System

## X-ray Table Examination Procedures

---

### 4.8.3 Pendulum Mode

#### 4.8.3.1 General

The *Pendulum mode* is designed for non-vertical examinations of patients lying on the Table.

#### 4.8.3.2 Flow of Operation

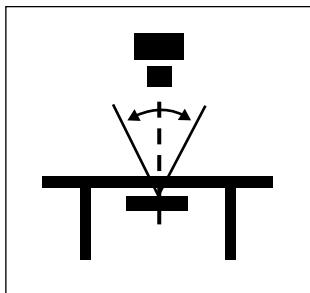

Select a *Pendulum mode* examination.

The System display shows, see **Fig. 4-26**.

Fig. 4-26 *Pendulum mode display*

- The SID is displayed.

Activate the mode by pressing the servo button.

- The overhead tube crane moves automatically to its programmed position.
- The overhead tube crane moves to the programmed SID.

Adjust the height of the Table stand.

- The overhead tube crane follows the Table stand to maintain the programmed SID.

Press the arrow left or corresponding buttons on the table handle.

- Press the buttons for moving the overhead tube crane to the right or left, see item F and G at **Fig. 3-53**. The tube move in the desired direction and the imaging unit move to stay aligned with the tube.

#### 4.8.3.3 Exposure

Exposure is possible when the overhead tube crane is not moving, and the servo button is activated.

### 4.8.4 Stitching Table Mode (Option)

Select a *Stitching Table mode* examination.

The system display shows the following, see **Fig. 4-27**.

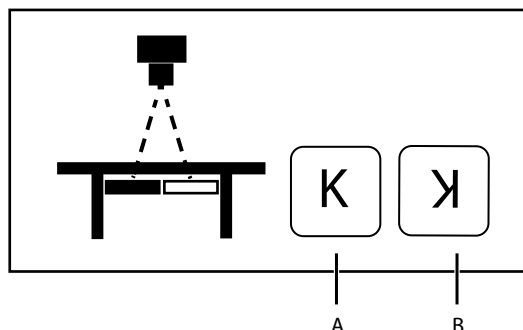

*Fig. 4-27 A = Left position / B = Right position.*

Activate the mode by pressing the servo button.

- The servo mode indication light flashes until the left and right positions are specified.
- The overhead tube crane moves automatically to its programmed position.
- The system beeps when position is reached.
- The OTC light is flashing yellow to indicate that action is needed by the user.

Invite the patient and position the patient on the table.

Move the focus point to the middle of the planned composite image. This could be done either by moving the tabletop.

Rotate the x-ray tube in order for the right edge of the collimator light field to indicate the right limit for the composite image.

Press the button (**F1**) to set the right limit, see **Fig. 4-28**.

- The button turns green to indicate that the limit is set.

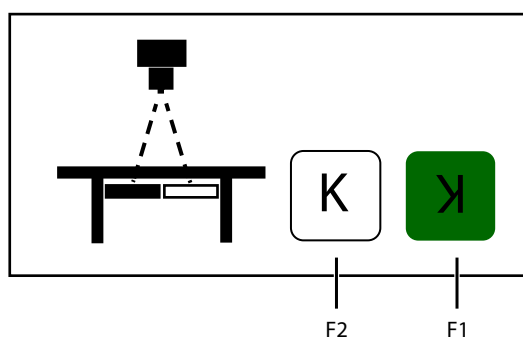

*Fig. 4-28 Set left/right limit*

# Operating the System

## X-ray Table Examination Procedures

---

Rotate the x-ray tube in order for the left edge of the collimator light field to indicate the left limit for the composite image.

Press the button (F2) to set the left limit, see **Fig. 4-28**.

- The button turns green to indicate that the limit is set.
- Data is present on the right side of the display.
- When both limits have been defined, the total length of the composite image (C), see **Fig. 4-29**, and the number of exposures (D) are shown.

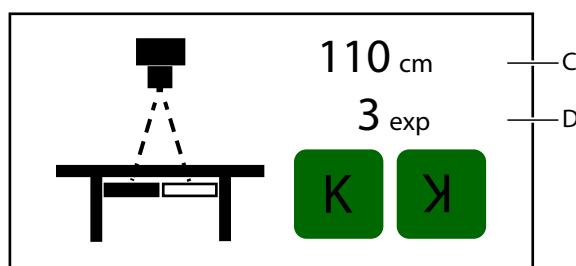

*Fig. 4-29 Left and Right Limits Set*

- The servo mode indication light is fixed.

Modify the exposure settings if necessary.

Activate the exposure button, and keep it activated during the procedure.

- The starting position is always at the left edge of the composite image. Activate the exposure button and keep it activated until the exposure procedure is completed. The system moves to the correct starting position.
- When the system is in the correct position for the first image, the first image is captured.
- After exposure, the system moves to the next correct position and the second image is captured.

This is repeated until all images for the composite image has been captured.

- The system beeps when the sequence is finished.

### 4.9 Wallstand Examination Procedures

#### 4.9.1 Wall Flexible Modes

##### 4.9.1.1 General

The *Wall Flexible modes* are designed for examinations of patients standing up against a vertical moving imaging unit.

The movement up/down of the overhead tube crane only changes the tube position, the wallstand does not follow.

##### 4.9.1.2 Wall Flexible Movements

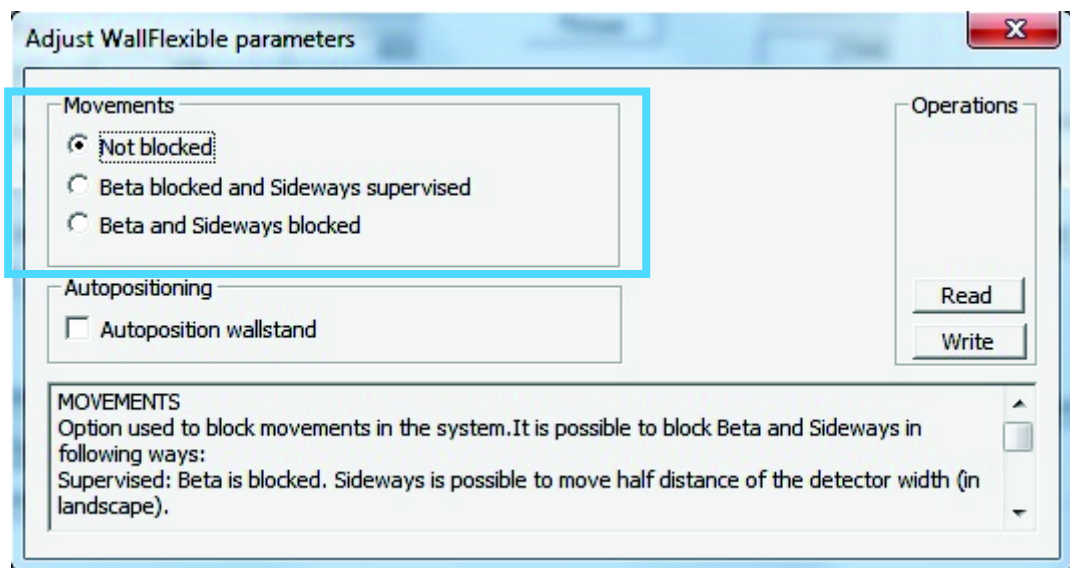

Fig. 4-30 Adjust WallFlexible parameters.

There are 3 different Wall Flexible Modes, all accessible from the Arcoma Service program, `Adjust WallFlexible parameters`. The *Wall Flexible Movements* shall be set at the installation, and are thereafter valid for all Auto positions using the *Wall Flexible mode*.

- **Not Blocked** — All overhead tube crane movements are allowed.
- **Beta blocked and Sideways supervised** — Blocked beta movement, movement is turn the servo off. It is possible to move a distance of half the detector length (landscape), before turning off the servo.
- **Beta and Sideways blocked** — It is only possible to move the overhead tube crane up and down. Beta and Sideways blocked – No sideways movements allowed. Blocked non-FFD directional (X/Y) movement, movement is turn servo off and block exposure.

# Operating the System

## Wallstand Examination Procedures

---

### 4.9.1.3 Basic Flow

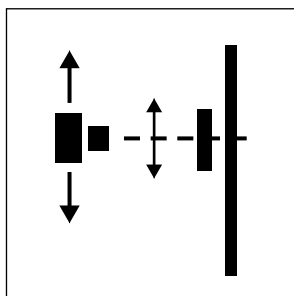

Fig. 4-31 Wall Flexible mode display

Select a *Wall Flexible mode* examination.

See Fig. 4-31.

- The SID is displayed.

Activate the mode by pressing the servo button.

- All movements are available.
- The overhead tube crane moves automatically to its programmed position.
- The overhead tube crane either goes direct to an aligned position to the detector or waits in the transportation height until detector is moved (wait or no wait selected).
- The mode stays activated. The overhead tube crane beeps once and the servo mode indication light flashes.

Adjust the height of the wallstand.

Move the detector holder at the wallstand.

- The overhead tube crane moves down and align with the wallstand.
- The overhead tube crane follows the wallstand to stay aligned.
- The overhead tube crane turns on the collimator light when the correct height is reached.

Adjust the position.

- The mode stays activated.
- The *SID* value is changed to the new distance (if selected distance toward the wallstand is changed).

### 4.9.2 NoWait Configuration



#### **WARNING!**

---

***The wallstand immediately starts tracking the height of the detector.***

---

At the installation of the System, it is possible to select that the System shall not wait for the user to move the wallstand.

The flow then is as follow;

Select a *Wall Flexible mode* examination.

- The SID is displayed.

Activate the mode by pressing the servo button.

- All movements are available.
- The overhead tube crane moves automatically to its programmed position.
- The overhead tube crane moves down and align with the wallstand detector.
- The overhead tube crane follows the wallstand detector to stay aligned.
- The overhead tube crane reaches the correct height and stops.
- The *SID* value is changed to the new distance (if selected distance toward the wallstand is changed).

#### **4.9.2.1 Exposure**

Exposure is possible when the overhead tube crane stands still, and the servo mode indication light is fixed.

# Operating the System

## Wallstand Examination Procedures

---

### 4.9.3 Stitching Wallstand Mode (option)



#### **WARNING!**

**The wallstand detector holder moves during stitching. This may cause danger for the patient.**

**Always assure that the patient protection is positioned between the patient and the moving detector before exposure.**

**Inform the patient that the detector moves during this procedure.**

---

Select a *Stitching wallstand mode* examination.

The System display displays the following.

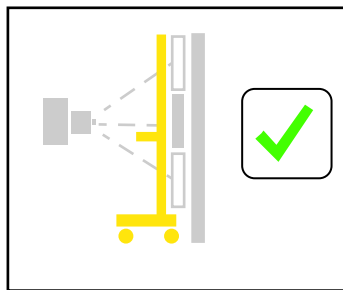

Fig. 4-32 Patient protection

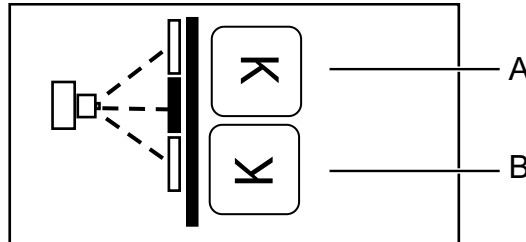

Fig. 4-33 Stitching wallstand mode examination

The following buttons and information are located in the display, as shown in **Fig. 4-33**:

A High position

B Low position

1. Activate the mode by pressing the *servo* button.
  - The servo mode indication light and OTC light flash yellow until both limits are defined.
  - The overhead tube crane moves automatically to its programmed position.
  - The System beeps when position is reached.
2. Install a patient protection in front of the wallstand.
3. Invite the patient and position the patient in front of the wallstand.
4. Verify that the patient protection is placed in front of the wallstand by pressing the *green check* button on the display, see **Fig. 4-32**.
5. Move the focus point to the middle of the planned composite image. This could be done by moving the tube in Z direction.
6. Rotate the x-ray tube in order for the lower edge of the collimator light field to indicate the lower limit for the composite image.



- Press the button to indicate the lower limit. The button turns green.

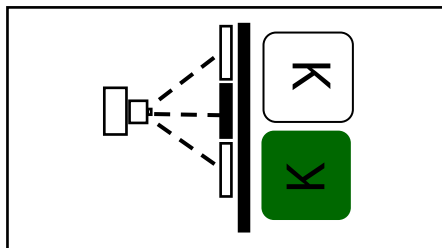

Fig. 4-34 Lower limit indication

- Rotate the x-ray tube in order for the upper edge of the collimator light field to indicate the upper limit for the composite image.
- Press the button to indicate the upper limit.
  - The button turns green to indicate that the limit is set.

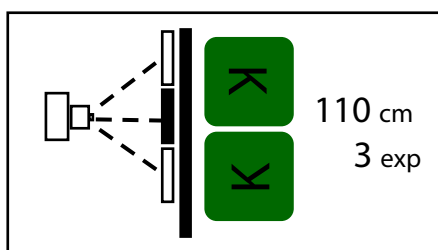

Fig. 4-35 Stitching mode — upper and lower limit set

- When both limits have been defined the total length of the composite image and the number of exposures is shown.
  - The servo mode indication light is fixed and the OTC light switches to fixed green light to indicate that exposure is possible.
- Modify the exposure settings if necessary.

**Note!** \_\_\_\_\_

*For a stitching procedure, a change of the patient size or change of exposure parameters for the first image included in the sequence, is not kept for the following included images.*

---

- Activate the *Exposure* button and keep it activated during the procedure.
  - The starting position is always at the top edge of the composite image. Activate the *Exposure* button and keep it activated until the exposure procedure is completed.
  - The System moves to the correct starting position.
  - When the System is in the correct position for the first image, the first image is captured.
  - After exposure, the System moves to the next, correct position and the second image is captured.
  - This is repeated until all images for the composite image has been captured.
  - The System beeps when the sequence is finished. Release the button.

### 4.9.4 AEC Technique Setup

For information about the AEC Technique setup, see the *Generator Manual*.

# Operating the System

## Detector, Wallstand

---

### 4.10 Detector, Wallstand



#### **WARNING!**

---

- *Before setting or adjusting the detector and other equipment, complete the setting of the counterweights.*
  - *Whenever any item is removed from the wallstand, e.g. the lateral armrest, the detector holder becomes highly unbalanced.*
  - *Whenever the brake is released, it moves upward and may cause injury.*
  - *Make sure that the operation is done by personnel who are trained in the use of the equipment.*
  - *Shutdown the power when changing a permanent detector.*
  - *Confirm that it is not possible to elevate. If the detector holder elevates accidentally while work is being carried out, it may fall against the worker and result in serious injury.*
- 

#### **CAUTION!**

---

*Do not put any load on the detector tray. It might be damaged.*

---

#### **CAUTION!**

---

*Always supervise movements of the detector to avoid collision with peripherals.*

---

#### **Note!**

---

*This instruction applies only to the portable image receptor.*

---

#### **Note!**

---

- *Depending on left or right operated wallstand, the location of the detector tray and position of button and latches is different.*
- 

#### **Note!**

---

*If the System includes more than one detector, assure that the active detector is used.*

---

### 4.10.1 14x17 inches Detector, Wallstand

#### 4.10.1.1 Method to Load 14x17 inches Detector, Wallstand

The method of setting the detector to the detector holder is as follows:

1. Pull the detector tray toward you until it locks.

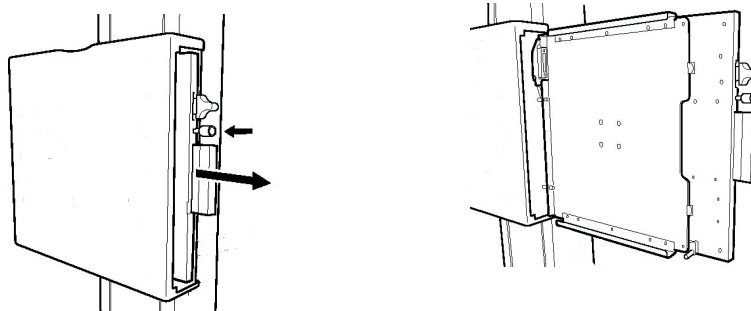

Fig. 4-36 Pull out detector tray

#### Note!

- Install the detector with the detector tray pulled into the locked position. When pulling the detector tray, the button on the side of the tray first recedes before snapping back into its original position when it locks.

2. Insert the detector into the detector holder, as shown below and set it by pushing it in, until it clicks.

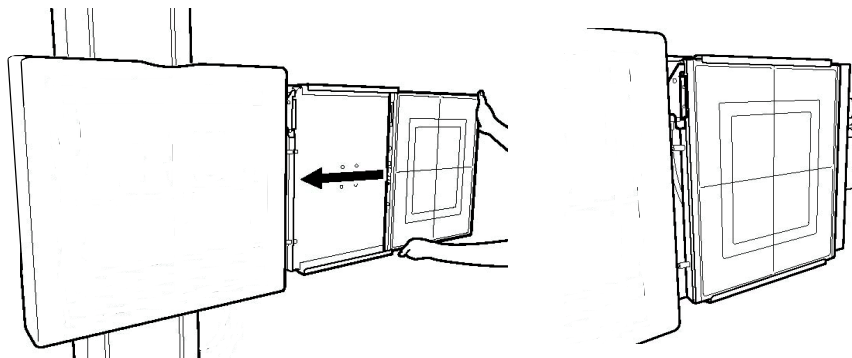
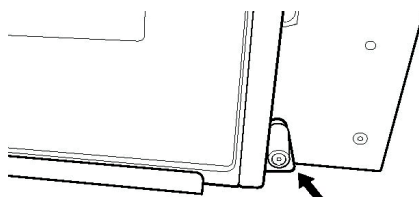

Fig. 4-37 Insert detector

#### CAUTION!

- Confirm that the latch is going up firmly, as shown below.



# Operating the System

## Detector, Wallstand

---

3. While pressing and holding the button of the detector tray, return it back to the inside of the detector holder.

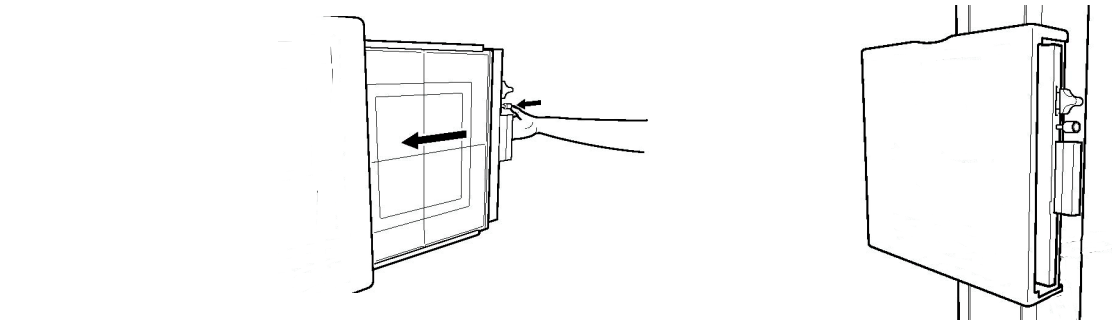

*Fig. 4-38 Return detector tray*

### 4.10.1.2 Change Between Portrait and Landscape

The method of rotating the detector in the detector holder, is as follows:

1. To rotate the detector by 90°, in the step 2 of “Method to set the detector”, hold the lower side of the detector and turn it from the below, clockwise or anti-clockwise (2) while pulling the latch upward or downward of the detector tray (1) in the direction of the arrow.

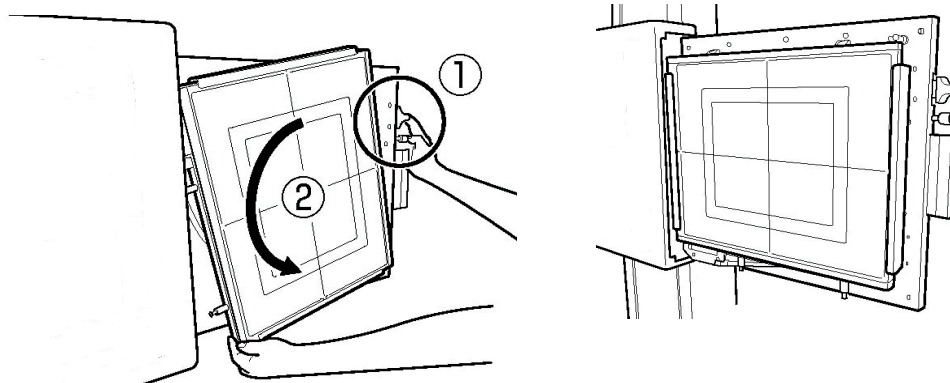

Fig. 4-39 Rotate detector

#### Note!

- To set the detector, pull the latch:
  - upward at upper position of the tray.
  - downward at the center of the tray.
- Depending on left— or right—operated wallstand, the location of the detector tray and position of button and latches is different.

#### Centered or Top Rotation of the Detector

In the landscape position, there is a choice between having the detector rotated through the detector center or through the detector top.

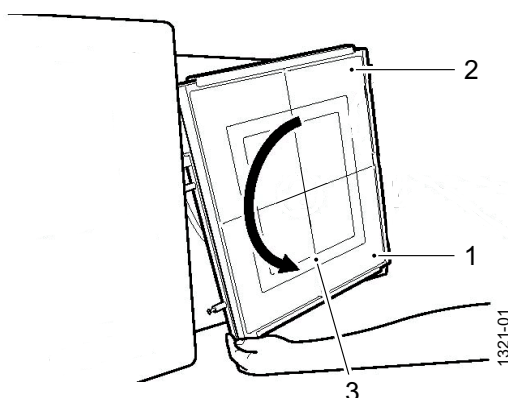

1. Center position landscape
2. Top position landscape
3. Portrait

Fig. 4-40 Rotating detector

# Operating the System

## Detector, Wallstand

---

### 4.10.1.3 Method to Remove 14x17 inches Detector, Wallstand

The method of removing the detector from the detector tray is as follows.

1. To remove the detector, in step 2 of "Method to set the detector", unlock the connector by pulling the latch of the detector tray in the direction of the arrow.

**Note!**

- Depending on left or right operated wallstand, the location of the detector tray and position of button and latches is different.
- 

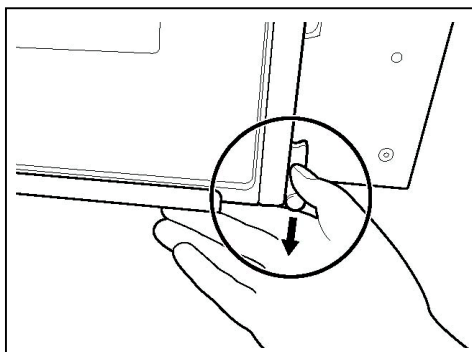

*Fig. 4-41 Unlocking detector latch*

### 4.10.2 17x17 inches Detector, Wallstand

#### 4.10.2.1 Method to Load 17x17 inches Detector

**Note!**

- Depending on left- or right-operated wallstand, the location of the detector tray and position of button and latches is different.
- 

The method of setting the detector to the detector holder is as follows;

The following instruction describes the detector operated from the left side.

1. Pull the detector tray toward you. Make sure the detector tray is completely brought out.

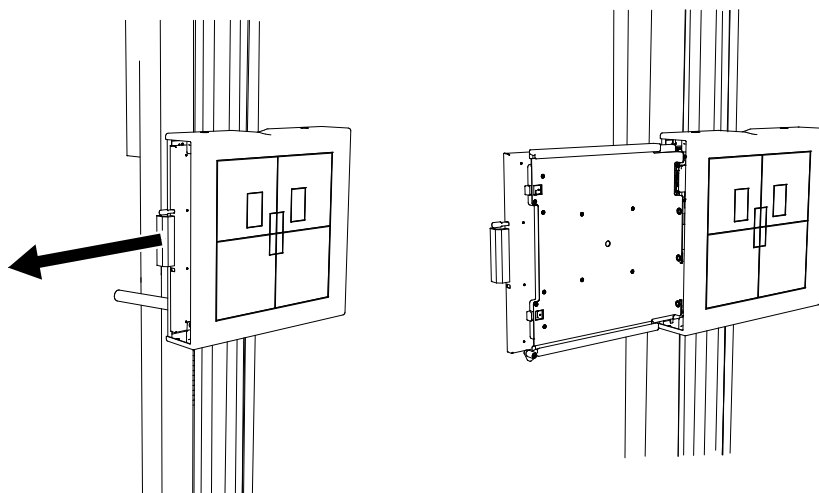

Fig. 4-42 Pull out detector tray

2. Insert the detector into the detector tray as shown below and set it by pushing the detector, holding down the latch.

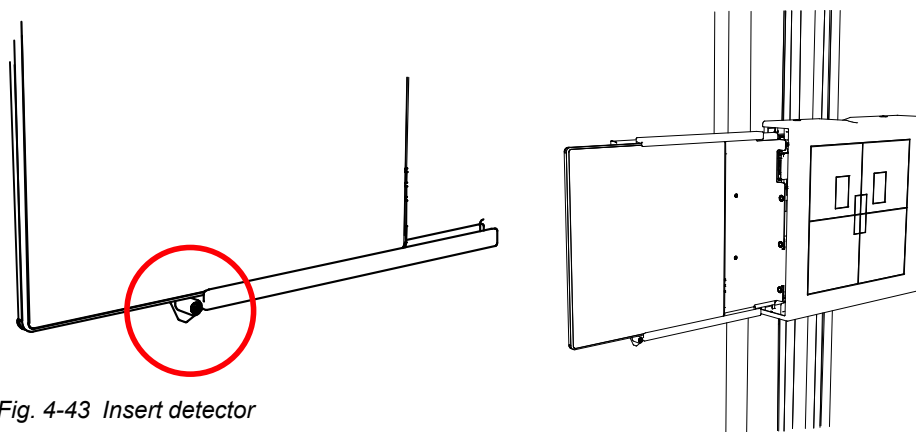

Fig. 4-43 Insert detector

# Operating the System

## Detector, Wallstand

---

3. While pressing and holding the button of the detector tray, return it back to the inside of the detector holder.

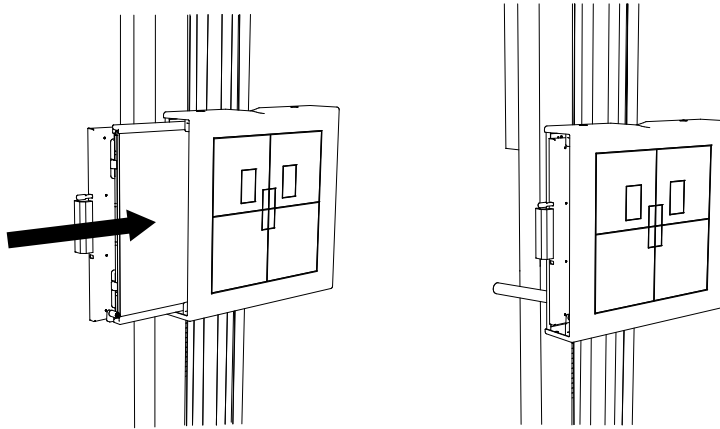

Fig. 4-44 Return detector

4. Push the detector until the hold-backs are set. Then the detector is in the correct position. Chargeable detectors start charging when set in this position.

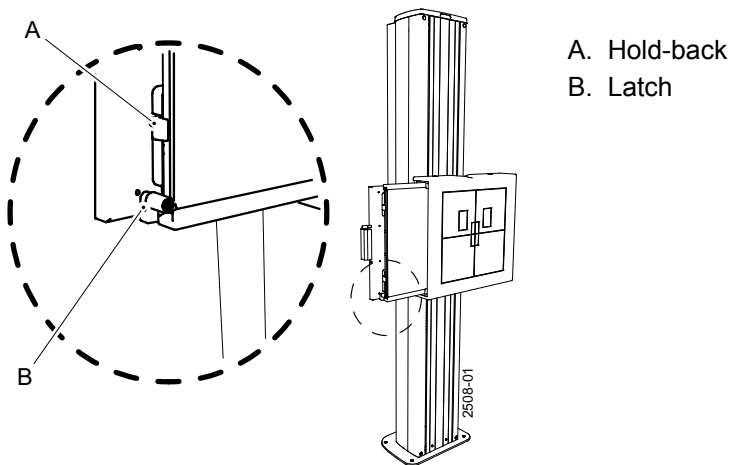

Fig. 4-45 Lock hold-back

### **CAUTION!**

---

**It is important that the hold-backs lock outside the detector end. Failure to position the detector in the proper position leads to incorrect images.**

---

### **Note!**

---

**If the detector or the detector holder is not properly inserted, a warning symbol is shown at the display.**

---



### 4.11 Portable detector, table

*Note!*

*This instruction applies only to a portable detector.*

**CAUTION!**

**Do not put any load on the detector tray. It might be damaged.**

**CAUTION!**

**Always supervise movements of the detector to avoid collision with peripherals.**

*Note!*

*If the System includes more than one detector, assure that the active detector is used.*

#### 4.11.1 Set the detector

1. Pull out the detector tray.

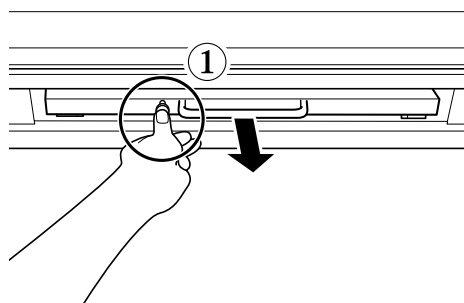

Fig. 4-46 Releasing the detector tray

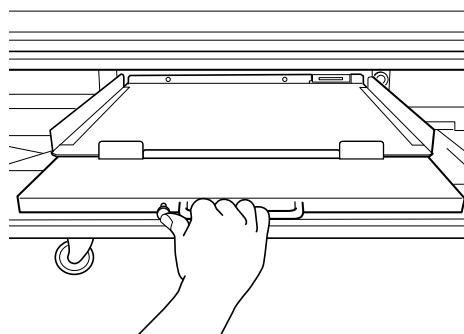

Fig. 4-47 Pulling out the detector tray

# Operating the System

## Portable detector, table

2. Insert the detector into the tray as shown below.

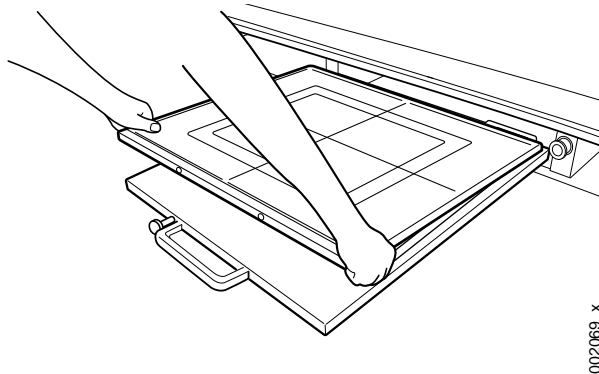

Fig. 4-48 Inserting the detector into the detector tray

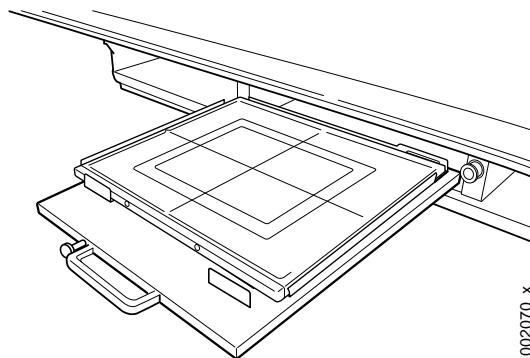

Fig. 4-49

3. In this position exposure is possible in *Free mode*, *Table Flexible mode* and *Auto position mode*.
4. Press and hold the button of the tray and push it in.

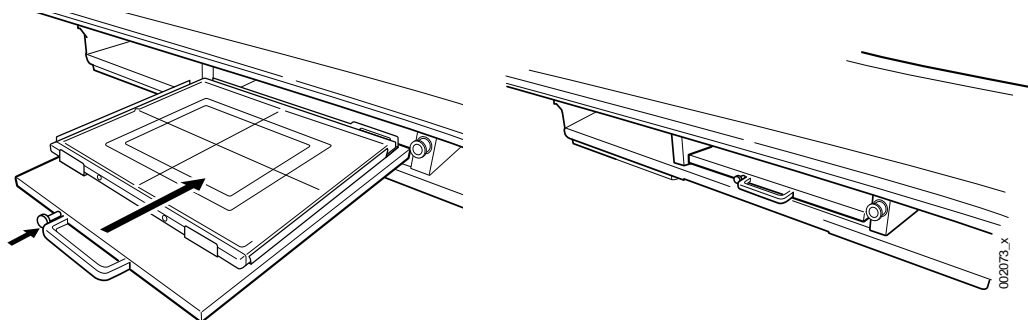
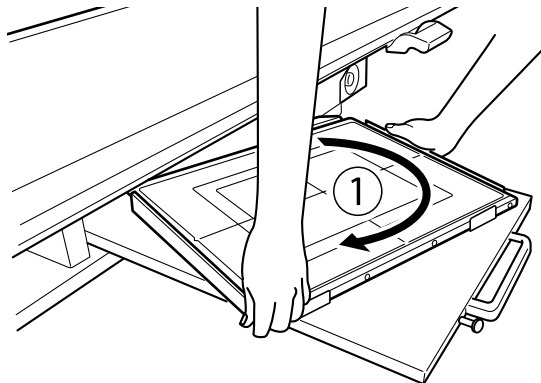

Fig. 4-50 Reinserting the detector tray

To check if the detector is in the right position, see the “STATE”; *Detector position/ present/undefined* at the display.

### 4.11.2 Change Between Portrait and Landscape

1. Rotate the detector 90°.
2. Hold as shown below and turn the detector, clockwise or anti-clockwise.



*Fig. 4-51 Detector change between portrait and landscape*

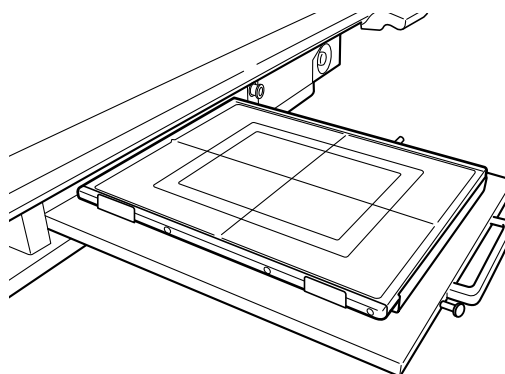

*Fig. 4-52*

# Operating the System

## Portable detector, table

---

### 4.11.3 Remove detector

1. Withdraw the detector holder and rotate the detector, if needed, to remove the detector.

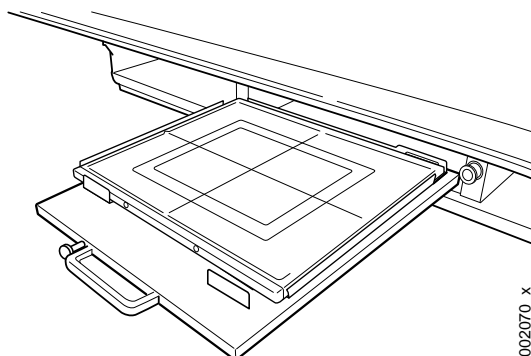

Fig. 4-53

2. Remove the detector by pulling it toward you according to **Fig. 4-54**.

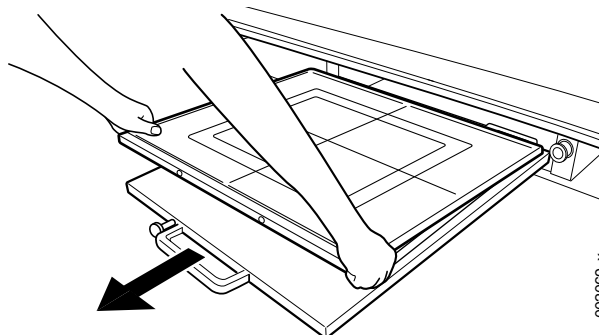

Fig. 4-54 Detector removal

### 4.11.4 Exchange Grid



#### **WARNING!**

**Failure to insert the grid in the correct orientation, with the tube side facing toward the X-ray source, can result in unsuccessful patient imaging.**

**Additional corrective patient imaging and additional ionising radiation exposure for the patient may be needed.**

**Ensure the grid is inserted in the correct way.**

1. Pull out the grid.

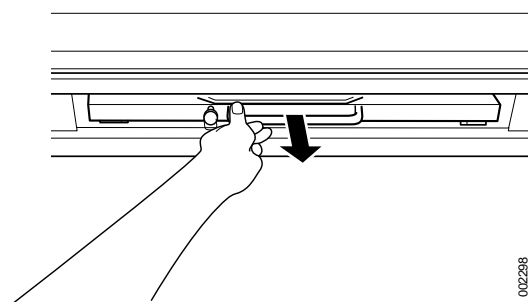

Fig. 4-55 Pull out the grid

2. Exchange the grid.

Insert the grid with the tube side facing up, toward the X-ray source. The tube side of the grid has the specification label and the grid centre line identification.

3. Push in the grid, until it clicks.

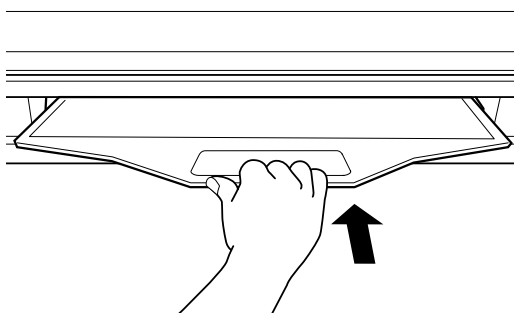

Fig. 4-56 Push in the grid

# Operating the System

Portable detector, table

---

## 5 Error Handling

### 5.1 Fault Handling

There are three types of NOTIFICATIONS - Shows the present occurrence. For example; collision. They are listed below in ranking order.

1. ERROR  
Information on the overhead tube crane display (red). Sound: two beeps.
2. WARNING  
Information on the overhead tube crane display (grey). Sound: one beep.
3. INFO  
No information in the overhead tube crane display but can be found in the setting menu.

#### 5.1.1 Notifications

##### 5.1.1.1 Error

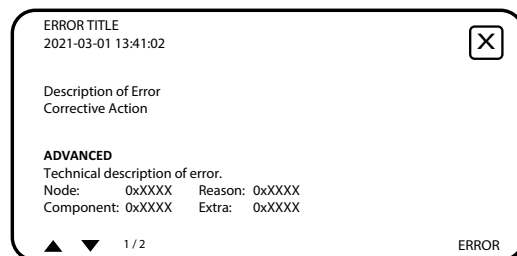

When an error occurs, an Error pop-up window appears on the OTC display.

Fig. 5-1 Error pop-up window

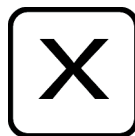

The Error pop-up window disappears when the user pushes the close button.

Fig. 5-2 Close button

# Error Handling

## Fault Handling

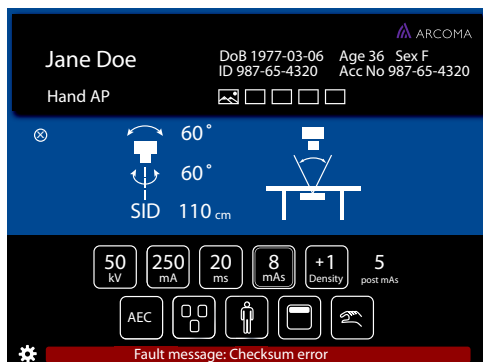

Fig. 5-3 Error information bar, table

### 5.1.1.2 Warning and Information

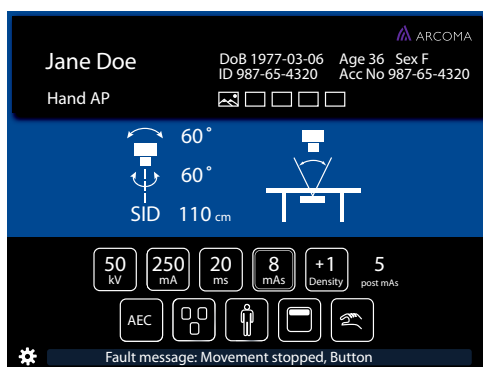

Fig. 5-4 Warning information bar

When closing the Error pop-up window, shown in **Fig. 5-1**, an information bar appears, see **Fig. 5-3**.

When the user pushes the information bar, the Error pop-up window appears again.

The Error information bar (lower part of the window) is present until the error is fixed or the System is restarted.

A warning message appears in an information bar (lower part of the display), when the handling of the System justifies that.

The information bar is cleared if/when a new message is displayed, or after time.

The latest sent message is shown.

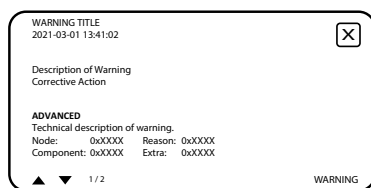

Fig. 5-5 Pop-up window — Warning information bar

When pushing the information bar, shown in **Fig. 5-4**, a pop-up window appears see **Fig. 5-5**.

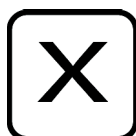

Fig. 5-6 Close button

The *Warning pop-up window* disappears when the user pushes the close button.

### 5.1.1.3 Log

The *Log file* is part of the *Setting menu* and reached by pressing the gear or the *Error/Warning messenger* bars.



### 5.2 Diagnostic

For System messages, error messages and error handling, see the System Installation and Service Manual.

# Error Handling

## Diagnostic

---

## 6 Cleaning and Disinfection

Cleaning is used for removal, usually with detergent and water or enzyme cleaner and water, of adherent visible soil, blood, protein substances, microorganisms and other debris from the surfaces, crevices, serrations, joints, devices, and equipment by a manual or mechanical process that prepares the items for safe handling and/or further decontamination.

Disinfection is used for chemical destruction of pathogenic and other types of microorganisms.

### 6.1 General

General guidelines for cleaning and disinfection of the system are given below.



---

#### **WARNING!**

##### ***Risk of electrical hazard or damage to the system***

- ***Before cleaning or disinfection, switch off the system to prevent electric shocks, for exceptions see 6.1.1 Cleaning and Disinfection Permitted with System Switched ON.***
  - ***Do not spray or pour cleaning liquid on any part of the system.***  
***Use a lint-free cloth moistened with a moderate amount of liquid to avoid that cleaning liquids seep into the openings of the system, e.g., air openings, gaps between covers.***
  - ***Do not restart the system if cleaning liquids have leaked in.***
- 

---

#### **CAUTION!**

##### ***Risk of damage***

***Use non-abrasive cleaning products to avoid scratches or damage to surfaces.***

---

### **6.1.1 Cleaning and Disinfection Permitted with System Switched ON**

For cleaning and disinfection of the following parts, the system can stay switched on:

- Lateral armrest
- Patient grips
- Chin rest
- Front cover of Bucky unit
- Tabletop
- Maneuver Handle and Display, see **6.4**.

# Cleaning and Disinfection

## Cleaning

---

### 6.2 Cleaning

- Wipe the system's parts with a lint-free cloth moistened with a moderate amount of mild soap or detergent solution until all visible signs of surface contaminants are removed.
- Remove all remaining cleaning residues and dry with a soft cloth.
- Keep the ventilation slots of all components unobstructed.
- Regularly clean the dust off all rails and joints etc.

See also separate instruction for **6.4 Maneuver Handle and Display**.

### 6.3 Disinfection

- Clean the surfaces/parts before disinfection according to **6.2 Cleaning**.
- Wipe the surface with a lint-free cloth moistened with a disinfectant.
- Do not spray any disinfectants directly on the surface.
- Obey the instructions of the manufacturer of the disinfectant.

See also separate instruction for **6.4 Maneuver Handle and Display**.

# Cleaning and Disinfection

## Maneuver Handle and Display

---

### 6.4 Maneuver Handle and Display

- Wipe the maneuver handle and display using a moderately moist cloth with water or alcohol-only cleaning agents only.
- Do not spray directly on the maneuver handle or the display.

## 7 Function And Safety Checks

### 7.1 AEC Functional Check

The following procedure may be used to verify that the AEC circuits are functioning on generators equipped with AEC (automatic exposure control).

1. Switch the generator ON, and select an appropriate radiographic image receptor.
2. Align the X-ray tube and the selected image receptor such that the central ray is directly over the center field of the AEC pickup device. Set the focal spot to film plane distance to 40 in. (1 m).
3. Select AEC mode of operation. Select center field, large focus.  
MINIMUM EXPOSURE TIME:
4. With no object in the radiation field, adjust the collimator or beam limiting device to project a 10 in. X 10 in. (24 cm X 24 cm) field at the image receptor.
5. Select 80 kVp, 100 mA, and a backup mAs of 50 if it is operator selectable. If this is not operator selectable, the default AEC backup settings must be used. Refer to the note at the end of this page to determine the AEC backup mode that has been programmed.
6. Make an exposure and verify that the POST mAs reading is 2 mAs.  
MAXIMUM EXPOSURE TIME:
7. Close the collimator or beam limiting device completely. Place a folded lead apron over the image receptor.
8. Select 60 kVp, 100 mA, and a backup mAs of 50 if it is operator selectable. If this is not operator selectable, the default backup settings must be used. Refer to the note at the end of this page to determine the AEC backup mode that has been programmed.
9. Make an exposure and verify that the AEC backup timer has terminated the exposure.

**Note!** \_\_\_\_\_

*The AEC backup mode is installer programmable. Three modes are available, **FIXED**, **MAS**, and **MS**. Only the **MAS** mode allows the operator to set the backup mAs for an AEC exposure.*

---

**FIXED:** The generator will determine the maximum AEC backup time, not to exceed pre-set AEC backup mAs/ms values or system limits. The characters **AEC** will be displayed in the time window of the LED display during AEC operation.

**MAS:** Allows the operator to adjust the AEC backup mAs, not to exceed preset AEC backup mAs/ms values or system limits. The mAs value will be displayed in the time window of the LED display during AEC operation.

**MS:** Allows the operator to adjust the AEC backup ms, not to exceed preset AEC backup mAs/ms values or system limits. The ms value will be displayed in the time window of the LED display during AEC operation.

# Function And Safety Checks

## Monthly Checks

---

### 7.2 Monthly Checks

#### 7.2.1 General

If any malfunction is detected, the entire equipment must be taken out of use until the problem is eliminated by a service technician from the supplier or by the local technical staff trained by the supplier.

*Note!* \_\_\_\_\_

*Before performing any maintenance please read the Safety chapter.*

---

Daily and monthly checks are normally performed by the user/operator.

Annual checks shall be performed either by local technical staff trained by the supplier or authorized service representatives.

Use the safety checklist **Appendix B** to verify the check.

Checks for all units.

overhead tube crane, table and wallstand:

- 1. Check the cable hose for damage.
- 2. Check all outer cabling for damage.
- 3. Clean all outer surfaces, except for the lubricated column segments.
- 4. Make sure that the Instruction for use is available and up to date.
- 5. Check the emergency stop. By activating the emergency stop all motorized movements are inhibited. See *Safety Chapter* for information on how the Emergency stop should react on command.

#### 7.2.2 Overhead Tube Crane

- 6. Power up the overhead tube crane and check all functions.
- 7. Move the overhead tube crane around and observe any irregularities.

#### 7.2.3 Table

- 8. Move the Table in X, Y and Z direction to make sure it runs smoothly and sounds OK.
- 9. Move the table top longitudinal and check that the mechanical end stops are not loose.

#### 7.2.4 Wallstand

- 10. Move the wallstand up and down in Z direction and make sure it runs smoothly and sounds OK.



## 8 Complying Standards

IEC 60601-1:2005+AMD1:2012+AMD2:2020 (edition 3.1)

- Medical electrical equipment: General requirements for basic safety and essential performance.

IEC 60601-1-2:2014 (4th edition)

- Medical electrical equipment : General requirements for basic safety and essential performance - Collateral Standard: Electromagnetic disturbances - Requirements and tests.

IEC 60601-1-3:2008+AMD1:2013

- Medical electrical equipment: General requirements for basic safety and essential performance - Collateral Standard: Radiation protection in diagnostic X-ray equipment.

IEC 60601-1-6: 2010+AMD1:2013+AMD2:2020

- Medical electrical equipment: General requirements for basic safety and essential performance - Collateral standard: Usability.

IEC 60601-2-28:2017

- Medical electrical equipment: Particular requirements for the basic safety and essential performance of X-ray tube assemblies for medical diagnosis.

IEC 60601-2-54:2009+AMD1:2015+AMD2:2018

- Particular requirements for the basic safety and essential performance of X-ray equipment for radiography and radioscopy.

# Complying Standards

---

## 9 Technical specification

### 9.1 Power requirements

Mains voltage for the System	400VAC 3Phase+N, +/-10%, 50/60Hz 400VAC 3Phase, +/-10%, 50/60Hz 480VAC 3Phase, +/-10%, 50/60Hz Long-time (positioning) 2 A 50/60 Hz. Momentary (exposure):150 A, 50/60 Hz (Short term peak value), (recommended fuse 63 A, thermal breaker, B curve.) Class 1
Heat dissipation	1713 BTU/H

# Technical specification

## Power line requirements

### 9.2 Power line requirements

Generator Series and Mains Voltage	Generator Momentary Line Current	Apparent Mains Resistance	Recommended Minimum			
			Mains Disconnect to Generator (15 ft/5 m max)	Generator Service Rating	Distribution Transformer Rating	Ground Wire Size
50 kW 400 VAC, 3p	100 A	0.17 Ω	13.3 mm <sup>2</sup> (AWG 6)	100 A	65 kVa	13.3 mm <sup>2</sup> (AWG 6)
65 kW 400 VAC, 3p	125 A	0.13 Ω			85 kVa	
80 kW 400 VAC, 3p	155 A	0.10 Ω			105 kVa	
50 kW 480 VAC, 3p	80 A	0.24 Ω			65 kVa	
65 kW 480 VAC, 3p	105 A	0.19 Ω			85 kVa	
80 kW 480 VAC, 3p	130A	0.15 Ω			105 kVa	

### 9.3 Radiographic Specification

Radiographic performance	
kVp range:	40 to 150 kV
kVp steps:	variable in 1 kV steps
kVp accuracy:	$\pm (5 \% + 1 \text{ kV})$ measured 5 ms after the beginning of the exposure: $\pm 2\%$ between 70-80 kVp
Rise time (10-90%):	< 1.5 ms (typically < 1.0 ms) with 30 m (100 ft) Locaflex L3 or equivalent HV cables (4.4 $\mu\text{F}$ $\pm 10\%$ )
Time range:	1.0 to 6300 ms
Exposure time steps:	Variable in 1 ms steps via protocol: Variable according to ISO 497 Series R'20 via console
Exposure time accuracy:	$\pm (2\% + 0.5 \text{ ms})$ from 5 ms to 6300 ms and $> 0.5 \text{ mAs}$ $\pm (10\% + 1 \text{ ms})$ for $> 0.1 \text{ mAs}$ and for $< 5 \text{ ms}$ or $\leq 0.5 \text{ mAs}$ for 30 m (100 ft) HV cables
mAs range:	0.1 to 630 mAs (50 kW) 0.1 to 800 mAs (65 kW) 0.1 to 1000 mAs (80 kW) Note for Minimum mAs: mAs Mode: 0.3 mAs ( $> 60 \text{ kV}$ , 28 mA, 11 ms) mA, ms Mode: 0.3 mAs ( $> 60 \text{ kV}$ , 10 mA, 30 ms) mAs or mA, ms Mode: 0.1 m As (40 - 60 kV, 10 mA, 10 ms)
mAs accuracy:	$\pm (10 \% + 0.2 \text{ mAs})$ $\pm (10\% + 0.05) \text{ mAs}$ : 0.1 mAs - 0.5 mAs (preliminarily specified for the range beyond IEC standard)
mA range:	10 to 630 mA (50 kW) 10 to 800 mA (65 kW) 10 to 1000 mA (80 kW)
mA steps:	Variable in 0.1 mAs steps via protocol: Variable according to ISO 497 Series R'20 via console

# Technical specification

## Radiographic Specification

Radiographic performance	
mA Accuracy (10 mA -1000 mA):	<p><math>\pm</math> (5% +1 mA) for exposures <math>\geq</math> 5 ms and <math>&gt;</math> 0.5 mAs:</p> <p><math>\pm</math> (20%) mA for exposures <math>&gt;</math> 0.1 mAs and for <math>&lt;</math> 5 ms or:  <math>\leq</math> 0.5 mAs: (0.1- 0.25 mAs, mA 50 mA)</p>
Coefficient of linearity:	$\leq$ 0.1 for kV and mAs parameters
Coefficient of reproducibility:	$\leq$ 0.05 (Station to Station) for exposures $\geq$ 25 mA or 3.2 ms
Duty Cycle:	Not to exceed 5 consecutive boosts, followed by a minimum 10 second wait period

Output Parameter and Loading Factor		
Output Parameter	Generator Series	Loading Factor
Maximum X-ray tube voltage and highest X-ray tube current at that voltage	50 kW	150 kV, 320 mA
	65 kW	150 kV, 400 mA
	80 kW	150 kV, 500 mA
Maximum X-ray tube current and highest X-ray tube voltage at that current	50 kW	630 mA, 80 kV
	65 kW	800 mA, 81 kV
	80 kW	1000 mA, 80 kV
Combination of X-ray tube current and X-ray tube voltage resulting in highest output power	50 kW	500 mA, 100 kV, 0.1 s
	65 kW	630 mA, 100 kV, 0.1 s
	80 kW	800 mA, 100 kV, 0.1 s
Nominal shortest irradiation time (AEC exposures)	All models (AEC control is available over the full kV and mA range)	<p><math>&lt;</math> 2 ms with a dedicated or 3 of 5 field</p> <p>AEC board</p> <p>AEC control is achieved by varying the ms of the exposure. The AEC ms range is 15 ms to an installer-programmable maximum not to exceed 600 mAs.</p>
AEC Accuracy	All models	Coefficient of variation of measured air kerma $\leq$ 0.05

### 9.4 Collimator

X-ray rating up to	150 kVp
Collimation	Square field multilayer
Inherent filtration	Min. 1.2 mm Al/75KV
Selectable additional filtration	0 mm Al + 0 mm CU 1 mm Al + 0.1 mm Cu 1 mm Al + 0.2 mm Cu 2mm Al + 0.3 mm Cu
Square X-ray field selection	Min: 0.3 x 0.3 cm Max: 48 x 48 cm ( $\pm 1\%$ at 1 m SID ) (to reach 43 x 43 cm at 90 cm SID )

# Technical specification

## X-ray Tube

---

### 9.5 X-ray Tube

Inherent filtration	0.7 mm Al/75KV
Added filtration	0.8 mm Al
Total filtration	1.5 mm Al (0.7+0.8)

For more detailed x-ray tube technical specifications, see the provided tube insert and housing datasheets.



### 9.6 Environmental Requirements

Ambient transport and storage temperature	-25°C - +70°C
Ambient operating temperature	+10°C- +40°C
Transport and storage humidity (relative)	10-90%, non-condensing
Operating humidity (relative)	30-75% RH, non-condensing
Maximum transport and storage altitude	3000 m
Maximum operating altitude	3000 m
Maximum air pressure	700–1060 hPa
Noise	55dB or less (except single noise)

# Technical specification

## Ceiling Suspended X-Ray Tube Support

---

### 9.7 Ceiling Suspended X-Ray Tube Support

#### 9.7.1 General

Rotation range ceiling (beta)	>340°
Rotation range tube arm (alpha)	>±135°
Column (Z stroke)	1750 mm

#### 9.7.2 Configuration

Overhead tube crane	The overhead tube crane is a mechanical part of an X-ray system.
---------------------	--

#### 9.7.3 Weight

Total weight Overhead tube crane (4x4m traverse and ceiling rail) including cabling	340 kg
Overhead tube crane (including tube and collimator, ceiling wagon, column)	165 kg
Traverse (X-ray assembly, 4 m)	95 kg
Ceiling rail Y (4 m standard)	28 kg/each

#### 9.7.4 Electrical Characteristics

Mains voltage	230 VAC, 50/60 Hz center tapped single phase 4 A
---------------	--

#### 9.7.5 Classification

Classification according to IEC 60601-1.

Class	Class I equipment. All dead metal parts of the equipment are electrical connected to protective earth.
Applied part	Type B
Protection against ingress of water	IPX0
Mode of operation	Intermittent operation: 20%, maximum 1 min. ON / 4 min. OFF
Use of anaesthetic mixtures	The equipment is not suitable for use in the presence of flammable anaesthetic mixtures with air or with oxygen or with nitrous oxide.

# Technical specification

## Ceiling Suspended X-Ray Tube Support

---

### 9.7.6 Speed

	Low speed	Maximum speed
Z movement	60 mm/s	
X movement	250 mm/s	500 mm/s
Y movement	250 mm/s	500 mm/s
$\alpha$ movement	16°/s	
$\beta$ movement	16°/s	
Image receptor holder movement (with 50 kg mass)	166 mm/s	350 mm/s

# Technical specification

## Cabinet

---

### 9.8 Cabinet

Dimensions (L x W x H) mm	750 x 600 x 1125 mm
Weight	Max 134 kg

### 9.9 Table

#### 9.9.1 Column

Lowest table top position (from the floor to the table top surface)	550 mm
Column (Z stroke)	380 mm

#### 9.9.2 Table Top

Table top dimensions	2424 mm x 850 mm
Table top transparent area	2360 mm x 601 mm
Table top thickness	21.5 mm
Length of stroke, X direction	± 600 mm
Length of stroke, Y direction	± 150 mm
Movement range of the imaging unit	>650 mm
Movement range of the detector	up to 850 mm

#### 9.9.3 Weight

Table	Approximately 150 kg
Imaging unit	Approximately 21 kg
Table top	Approximately 47 kg
Maximum patient load	300 kg

#### 9.9.4 Electrical Characteristics

Maximum power without external electronics	500 W
--	-------

#### 9.9.5 Attenuation Equivalent

Table top	< 0.9 mm AL at 3.7 mm HVL
Detector holder	≤ 0.6 mm AL at 3.7mm HVL

# Technical specification

## Wallstand

---

### 9.10 Wallstand

Column, Z stroke	1580 +10/-10
Rotation range detector holder wagon (Only the tiltable detector holder wagon).	-20° - 90°
Attenuation Equivalent Detector holder	≤ 0.6 mm AL at 3.7mm HVL
Weight	200 kg ±10
Maximum speed Z movement	200 mm/s

## 10 Waste Disposal

The Manufacturing company is responsible for disposal of the system.

To avoid environment pollution and human injury, we therefore request that you contact the Manufacturer or your dealer if you wish to cease operation of your system with the intention of disposal.

For disposal of other components, refer to corresponding documentation.

Follow the rules and regulations of your relevant authorities in the disposal of this system, accessories, options, consumables, media and their packing materials.

# Waste Disposal

---



## 11 Accessories

### 11.1 General



#### **WARNING!**

*Due to squeezing hazards from motorized movements, only accessories approved by the Manufacturer are allowed.*

#### 11.1.1 General Accessories

Part no.	Description
0510-099-001	Cable carriage (1 piece)
0072-099-210	External servo button incl. emergency stop
0512-099-001	Unistruts for rails 4x4m
0512-099-002	Unistruts for rails 4x5m
0512-099-003	Mounting kit, unistruts for rails 4x4m
0512-099-004	Mounting kit, unistruts for rails 4x5m

#### 11.1.2 Table

Part no.	Description
0072-095-170	Patient kit includes:
	- Compression belt, cost effective
	- Patient handgrip (2 pieces)
	- Mattress
0072-099-014	Patient handgrip
0055-099-001	Mattress, Comfort
0055-099-007	Mattress, 2200 mm
0055-099-009	Hand control for automatic collimator (1 piece)
0072-099-011	Lateral cassette holder
0072-099-004	X, Y, Z Foot control
0055-099-025	X, Y Foot control strip type
0072-099-028	Compression belt, cost effective
0072-099-029	Compression belt, high-end
0080-099-051	Form pad, small-rectangle

# Accessories

## General

---

Part no.	Description
0080-099-050	Form pad, medium-wedge
0080-099-052	Form pad, large-head

### 11.1.3 Wallstand

Part.no.	Description
0182-099-320	Wall brackets WS

### 11.1.4 Detector

Part.no.	Description
CXDI-401C, wireless 43x43 compact	Canon detector
CXDI-402C, wireless 43x43	Canon detector
CXDI-410C, wireless 43x43	Canon detector
CXDI-701C, wireless 35x43	Canon detector
CXDI-702C, wireless 35x43	Canon detector
CXDI-710C, wireless 35x43	Canon detector
CXDI-810C, wireless ~28x35	Canon detector

### 11.1.5 Grid

Part.no.	Description
0180-099-050	Grid 40 lp/cm, 10:1 Ratio, F115, Al type
0180-099-051	Grid 40 lp/cm, 10:1 Ratio, F150, Al type
0180-099-052	Grid 40 lp/cm, 10:1 Ratio, F180, Al type
0180-099-060	Grid 52 lp/cm, 10:1 Ratio, F110, Al type
0180-099-076	Grid 52 lp/cm, 10:1 Ratio, F140, Al type
0180-099-061	Grid 52 lp/cm, 10:1 Ratio, F180, Al type
0180-099-082	Grid 52 lp/cm, 10:1 Ratio, F115, Carbon cover
0180-099-083	Grid 52 lp/cm, 10:1 Ratio, F180, Carbon cover

## 12 Appendix A

### 12.1 Glossary

#### A

Accessories	Extra facilities to the system which easily can be mounted by the user.
AEC	Automatic Exposure Control.
Alpha	A direction for a rotation movement.

#### B

Beta	A direction for a rotation movement. The tube turns around the Z-axis.
Btu/hr	British thermal unit/hour.
BU/Back-up	A precautionary measure that shuts off the exposure, if the AEC chamber does not.
Bucky	See Detector holder.

#### C

CE	A CE-marked product verifies that the Manufacturer guarantees that the product fulfils the EU fundamental health, environment and security requirements.
Centering	The field of image is centered over the detector.
Collision	Either a physical collision with an obstacle or the node cannot reach its end position.
CR	Image plates.

#### D

DAP meter	Dose Area Product meter. The DAP-meter is placed next to the collimator and measures the amount of X-ray radiation that leaves the collimator.
Diode	Electrical component that leads voltage and current in one direction.
Dealer	See "Supplier".
Detector	Image receptor for X-ray that does not require a cassette. The reception and transfer of an image is digital.

# Appendix A

## Glossary

---

### E

EMC	Electromagnetic Compatibility.
End stop	See mechanical end stop and software end stop.
Exposure	An image is taken against an image receptor.

### G

Guard function	Collision detection of the Z-movement (option).
Guard sensor	A sensor in the top of the Z-column that registers variations of force.

### I

IEC	International Electrotechnical Commission.
Image receptor	Receptor for images: Film, CR, DR, or Cassette.
Image receptor holder	Holder for the image receptor (Film, CR, DR or Cassette).
Index	Mechanical position markings, for instance alpha 0°, +90° and -90°.
Intermittence	The number of repetitions / unit of time. Recurrent cycles.
ISO	International Organization for Standardization.

### M

Mechanical end stop	A physical device that stops an automatic or manual movement if the software end stop is out of order.
Motorized movement	A motor assisted movement.

### N

Node	A control and supervision unit, consists of printed circuit board and node specific software.
------	---

### O

O.D.	Optic Density.
Options	Extra facilities that demand updating of the System software and hardware before use. Options demand installation of an authorized service technician.

### P

Position                    A location in the room (X, Y and Z).

### S

SID                            Source to image distance. The distance between the focus spot in the X-ray tube and the active image receptor surface. FFD is also used.

Software end stop        A non-physical device that stops an automatic or manual movement. The software end stop is placed before the mechanical end stop.

SSW                           Service software.

Supplier                    The company that sells the System to the user (hospital).

### T

Table frame                The metallic frame that carries the Table top. The frame is attached to the bottom of the Table top.

### W

Working area              The size of the Table top including X- and Y-stroke.

### X

X-movement                The System moves in the X-direction.

### Y

Y-movement                The System moves in the Y-direction.

### Z

Z-node                      The Z-node controls the Z-movement.

Z-movement                The System moves in the Z-direction.

# Appendix A

## Glossary

---

## 13 Appendix B

### 13.1 Monthly Checklist

Make a copy of this paper before filling in.

If there is any discrepancy, please use the table to make a note.

Hospital:.....

Id no:.....

Room:.....

Sign:.....

Date:.....

#### 13.1.1 Overhead Tube Crane

- 1. Move the overhead tube crane manually to all positions in X, Y and Z direction and make sure it runs smoothly and sounds OK.
- 2. Check the emergency stop. By activating the emergency stop all motorized movements are inhibited.
- 3. Choose table position and make sure the tracking is activated.  
Measure between the X-ray tube focal spot and the active image receptor surface of the image receptor holder. The measured SID shall correspond with the displayed *SID*.  
Move the overhead tube crane in X or Y direction and measure between the X-ray tube focal spot and the active detector surface of the detector holder again. The SID is allowed to differ  $\pm 1\%$ .
- 4. Check that the *SID*, shown on the display of both the Image system and the collimator, correspond with the measured SID.
- 5. Check the hoses for damage.
- 6. Check all outer cabling for damage.
- 7. Clean all outer surfaces, except for the lubricated column segments. See Chapter "*Cleaning*" at the *Instruction for use*.

# Appendix B

## Monthly Checklist

---

### 13.1.1.1 General

#### Checks for All Units Overhead Tube Crane, Table and Wallstand

- 1. Make sure that the *Operation Manual* is available and up to date.
- 2. Check the hoses for damage.
- 3. Check all outer cabling for damage.
- 4. Clean all outer surfaces, except for the lubricated column segments. See *Operation Manual, Chapter 6 "Cleaning"*, for cleaning instructions.
- 5. Check the emergency stop.  
By activating the emergency stop, all motorized movements are inhibited. See *Chapter 2, "Safety"*, for information of how the Emergency stop should react on command.

### 13.1.1.2 Overhead Tube Crane

- 6. Power up the Ceiling suspended unit and check all functions.
- 7. Move the Ceiling suspended unit around and observe any irregularities.

### 13.1.1.3 Table

- 8. Move the Table in X, Y and Z direction and make sure it runs smoothly and without any dissonance.
- 9. Move the Table top in longitudinal direction and check that the mechanical end stops are not loose.

### 13.1.1.4 Wallstand

- 10. Move the wallstand up and down in Z direction and make sure it runs smoothly and sounds OK.



**13.1.2 Remark**

	Remark	Action	Int Note
No.			
1.	_____	_____	_____
2.	_____	_____	_____
3.	_____	_____	_____
4.	_____	_____	_____
5.	_____	_____	_____
6.	_____	_____	_____
7.	_____	_____	_____
8.	_____	_____	_____
9.	_____	_____	_____
10.	_____	_____	_____

# Appendix B

## Annual Checks

---

### 13.2 Annual Checks

Refer to Service and Installation Manual.

# Appendix B

## Annual Checks

---

