

# *Omnera<sup>®</sup> 400T*

*Manual-Positioning Digital Radiographic System*

## ***Installation and Service Manual***



Technical Publication: 0180-095-408-EN Rev. 6.1

**Canon**

CANON MEDICAL SYSTEMS USA, INC.

### **Disclaimer**

The standard warranty is void if the product has been intentionally modified, or damaged by accident, abuse or misuse. Additionally, this warranty is void if untrained personnel service the OMNERA® 400T equipment.

Lost profits, downtime, goodwill, damage to or replacement of property, and any costs of repairing the OMNERA® 400T resulting from a breach of warranty are not the responsibility of Canon Medical Systems

Specifications are subject to change without notice. Not responsible for typographical errors.

### **Notices**

No part of this publication may be reproduced, transmitted, transcribed, stored in a retrieval system or translated into any language or computer language, in any form or by any means, electronic, mechanical, magnetic, optical, chemical, manual or otherwise, without the prior written permission of Canon Medical Systems

**Note:** Photos and drawings used in this guide may be slightly different from the actual product.



Dispose of electronic equipment in accordance with local, state, and federal regulations.

THIS DOCUMENT CONTAINS PROPRIETARY INFORMATION AND SUCH INFORMATION  
MAY NOT BE DISCLOSED TO OTHERS FOR ANY PURPOSE NOR USED FOR  
MANUFACTURING PURPOSES WITHOUT WRITTEN PERMISSION FROM CANON  
MEDICAL SYSTEMS.

### **Trademarks**

OMNERA® is a registered trademark of Canon Medical Systems

All third-party brand names, product names, or logos appearing in this manual are the trademarks or registered trademarks of their respective owners.

Canon® is a registered trademark of Canon, Inc. and may also be a registered trademark or a trademark in other countries.

	<b>Rev</b>	<b>Date</b>
New release	6.1	2020-09



<b>1</b>	<b>Introduction .....</b>	<b>1</b>
1.1	Document information .....	1
1.1.1	<i>System documentation</i> .....	1
1.1.2	<i>Stylistic conventions</i> .....	1
1.1.3	<i>Document producer</i> .....	1
1.1.4	<i>Text emphasis</i> .....	1
1.2	Identification Labels .....	2
1.3	System Description .....	4
1.3.1	<i>Intended use</i> .....	4
1.3.2	<i>System Overview</i> .....	4
1.3.3	<i>Overhead Tube Crane Overview</i> .....	5
1.3.4	<i>0181 Closed Table 0181 Overview</i> .....	6
1.3.5	<i>0055 Two Column Table 0055 Overview</i> .....	7
1.3.6	<i>Wall Stand Overview</i> .....	8
<b>2</b>	<b>Safety .....</b>	<b>11</b>
2.1	Modification of equipment .....	11
2.2	Compliance .....	12
2.3	Precautions, Safety .....	13
2.4	Qualifications of personnel .....	16
2.4.1	<i>Operating personnel</i> .....	16
2.4.2	<i>Service personnel</i> .....	16
2.5	Service and Maintenance .....	17
2.6	Installation and repair .....	18
2.7	Safety and Warning Symbols .....	19
2.8	Safety and Warning Labels on the Equipment .....	20
2.9	Emergency Stop .....	21
2.10	Radiation and X-ray Tube .....	22
2.11	Mechanical Safety .....	23
2.11.1	<i>General</i> .....	23
2.11.2	<i>OTC, Mechanical Safety</i> .....	24
2.11.3	<i>Mechanical Safety, Table</i> .....	26
2.11.4	<i>Working area, Table 0055</i> .....	33
2.11.5	<i>Mechanical Safety, Wall Stand</i> .....	34
2.12	Safety Functions .....	35
2.12.1	<i>System</i> .....	35
2.13	Safety Zone, Definition .....	38
2.13.1	<i>Safety Zone, Table</i> .....	38
2.13.2	<i>Safety Zone, Wall stand</i> .....	39
2.14	Electromagnetic Compatibility (EMC) .....	40
<b>3</b>	<b>Theory of Operation .....</b>	<b>45</b>
3.1	System Description .....	45
3.1.1	<i>General</i> .....	45
3.2	Safety .....	46
3.3	Electrical Design .....	47
3.3.1	<i>General</i> .....	47
3.3.2	<i>Electrical Design, Ceiling Suspended Unit</i> .....	49
3.3.3	<i>Electrical Design Table 0181</i> .....	50
3.3.4	<i>Electrical Design Two column table (option)</i> .....	50
3.4	Mechanical Design .....	55
3.4.1	<i>OTC, Mechanical Design</i> .....	55
3.4.2	<i>0181 Table, Mechanical Design</i> .....	55
3.4.3	<i>Two column table (option)</i> .....	55
3.4.4	<i>Wall stand</i> .....	56

# Contents

---

3.5	Functional Description.....	57
3.5.1	<i>General</i> .....	57
3.5.2	<i>Description</i> .....	57
3.5.3	<i>Overhead tube crane</i> .....	58
3.5.4	<i>Automatic Collimator Version (option)</i> .....	60
3.5.5	<i>Functional Description, Table</i> .....	62
3.5.6	<i>Automatic Collimator Control, Table (option)</i> .....	69
3.5.7	<i>Functional Description Wallstand</i> .....	70
3.6	System techniques.....	88
3.6.1	<i>General user interface</i> .....	88
3.6.2	<i>Free technique</i> .....	88
3.6.3	<i>Tracking</i> .....	89
3.7	Software Design.....	95
<b>4</b>	<b>Installation.....</b>	<b>97</b>
4.1	General.....	97
4.2	Precautions, Installation.....	98
4.3	Tools Required.....	102
4.3.1	<i>Standard Tools</i> .....	102
4.4	Service PC.....	103
4.5	Tightening Torque.....	104
4.6	Shipping/Receiving.....	105
4.6.1	<i>Receiving</i> .....	105
4.6.2	<i>Storage Precautions</i> .....	105
4.6.3	<i>Return Authorizations</i> .....	105
4.6.4	<i>OTC</i> .....	106
4.7	Mechanical Installation of OTC.....	108
4.7.1	<i>Ceiling Rails Y</i> .....	108
4.7.2	<i>Traverse Rail X</i> .....	110
4.7.3	<i>Y Brake</i> .....	115
4.7.4	<i>Ceiling Wagon</i> .....	116
4.7.5	<i>Install Safety Clamp Ring</i> .....	119
4.7.6	<i>X-Brakes</i> .....	120
4.7.7	<i>Cable Channel</i> .....	121
4.7.8	<i>Connect Brake Y</i> .....	123
4.7.9	<i>Wall Attachment</i> .....	125
4.8	Mechanical Installation of Cabinet.....	126
4.8.1	<i>Cover for Cable Outlet</i> .....	126
4.8.2	<i>Remove Covers, Cabinet</i> .....	128
4.9	General.....	129
4.9.1	<i>Interfacing</i> .....	129
4.10	Cable Paths.....	130
4.11	Electrical Installation of OTC.....	131
4.11.1	<i>External Exposure Switch</i> .....	134
4.12	Install Imaging System.....	135
4.13	Electrical Installation of CPI Mini Console.....	136
4.14	Wireless Detector.....	137
4.15	Electrical Building Installation.....	138
4.15.1	<i>400VAC</i> .....	139
4.15.2	<i>480VAC</i> .....	144
4.15.3	<i>Mains</i> .....	148
4.16	Start-up Procedure.....	150
4.16.1	<i>Check Voltage of the Subsystem</i> .....	150
4.17	Alignment of OTC.....	152
4.17.1	<i>Alignment of OTC, X- and Y-direction</i> .....	153
4.18	Mechanical Installation of Wallstand.....	155

# Contents

4.18.1	Orientation of Wallstand.....	155
4.18.2	Unloading.....	155
4.18.3	Install CXDI-401G/401C Detector.....	156
4.18.4	Remove Back Cover.....	157
4.18.5	Install Counterweights.....	158
4.18.6	Alignment of Wallstand.....	160
4.18.7	Anchor Location.....	161
4.18.8	Install Foot Control.....	163
4.18.9	Reassemble Back Cover, Wallstand.....	163
4.18.10	Wall Attachment for Cable Hose.....	164
4.19	Electrical Installation of Wallstand.....	165
4.19.1	Wallstand Detector with Charging.....	165
4.19.2	Connect Wallstand.....	166
4.20	Mechanical Installation of 0181 Table.....	169
4.20.1	Positioning the Pallet.....	169
4.20.2	Unloading the Table.....	169
4.20.3	Safety Clamp.....	175
4.20.4	Insulation.....	177
4.20.5	Adjust Horizontal Alignment.....	178
4.20.6	Attachment to Floor.....	179
4.20.7	Micro Switch End Stops.....	179
4.20.8	Attachment of Foot Pedal (X/Y/Z).....	181
4.20.9	Attachment of Maneuver Hand Control.....	182
4.20.10	Adjust Detector Holder.....	183
4.20.11	Remove the Red Safety Clamp.....	183
4.20.12	Reassemble the Covers.....	183
4.20.13	Two column table (option).....	184
4.21	Electrical Installation of Table.....	188
4.21.1	Connect Table.....	188
4.22	Finalize Table Installation.....	191
4.22.1	The Mechanical Stop.....	191
4.22.2	Install Table Top.....	192
4.22.3	Two column table (option).....	193
4.22.4	Installation of foot control Two column table (option).....	195
4.22.5	Installation of foot control strip type two column table (option).....	196
4.23	Protective Earth.....	197
4.23.1	Check Protective Earth.....	197
4.23.2	Measure Protective Earth.....	198
4.23.3	Protective Earth CS.....	199
4.23.4	Protective Earth Wallstand.....	200
4.23.5	Protective Earth Table.....	201
4.24	Alignment, Calibration and Adjustment.....	202
4.24.1	Collimator Light- and X-ray Field Alignment.....	202
4.24.2	Correspondence Between X-ray Field and Image Reception Area.....	205
4.24.3	Calibration of System and Service Software.....	205
4.24.4	Connections Image System Control PC.....	206
4.24.5	Detector Calibration.....	207
4.24.6	Connect OTC.....	208
4.24.7	Calibration of OTC Movement.....	214
4.25	Acceptance Tests.....	228
4.25.1	General.....	228
4.25.2	Peak Tube Potential.....	229
4.25.3	Tube Current.....	230
4.25.4	Exposure Time.....	232
4.25.5	Beam Quality.....	233
4.25.6	Reproducibility.....	234

# Contents

---

4.25.7	AEC (Automatic Exposure Control).....	235
<b>5</b>	<b>Maintenance .....</b>	<b>239</b>
5.1	General.....	239
5.2	Software Version / Update .....	241
5.2.1	<i>The Software and Its Update Location Point</i> .....	241
5.3	Function and Safety Checklist.....	242
5.3.1	<i>Annual Checklist</i> .....	242
<b>6</b>	<b>Diagnostic.....</b>	<b>253</b>
6.1	General.....	253
6.1.1	<i>Fault Handling</i> .....	253
6.2	System message two column table (option) .....	257
6.2.1	<i>General</i> .....	257
6.2.2	<i>Description</i> .....	257
6.2.3	<i>All Nodes</i> .....	258
6.2.4	<i>Motor Nodes</i> .....	260
6.2.5	<i>Master Node</i> .....	274
<b>7</b>	<b>Electrical drawings .....</b>	<b>277</b>
7.1	Notes regarding the electrical drawings .....	279
7.2	System block diagram (4C valid for Omnera 400T).....	281
7.2.1	<i>System</i> .....	281
7.2.2	<i>Image system</i> .....	283
7.2.3	<i>Subsystem</i> .....	321
7.2.4	<i>Overhead tube crane</i> .....	337
7.2.5	<i>System cabinet</i> .....	339
7.2.6	<i>Closed table</i> .....	341
7.2.7	<i>Two column table (option)</i> .....	343
7.2.8	<i>Wall stand</i> .....	345
7.3	Unit block diagram (4C valid for Omnera 400T).....	349
7.3.1	<i>Image system</i> .....	349
7.3.2	<i>Closed table</i> .....	351
7.3.3	<i>Two column table (option)</i> .....	369
7.3.4	<i>Wall stand</i> .....	383
7.3.5	<i>OTC</i> .....	403
7.3.6	<i>System cabinet</i> .....	419
<b>8</b>	<b>Fuses .....</b>	<b>421</b>
8.1	OTC .....	421
8.2	System cabinet.....	422
8.3	Two column table (option).....	423
8.4	Wall stand Z manual.....	424
8.5	Wall stand Z motorized.....	425
<b>9</b>	<b>Technical Specifications.....</b>	<b>427</b>
9.1	400T System .....	427
9.1.1	<i>Electrical characteristics</i> .....	427
9.1.2	<i>Environmental requirements</i> .....	429
9.1.3	<i>OTC</i> .....	429
9.1.4	<i>Cabinet</i> .....	430
9.1.5	<i>Wall stand</i> .....	430
9.1.6	<i>Closed table 0181</i> .....	431



# Contents

9.1.7	Two column table 0055 (option)	432
<b>10</b>	<b>Options</b>	<b>433</b>
10.1	General	433
10.2	Options for the system, with Canon image system	434
10.2.1	Ceiling Suspended X-ray Tube Support, Canon US	434
10.2.2	Options for Table	434
10.2.3	Options for Wall Stand	435
10.2.4	Detectors	435
10.2.5	System cabinet	436
10.2.6	Other options	436
10.2.7	Canon integration	436
10.3	Cube Installation	439
<b>11</b>	<b>Accessories</b>	<b>445</b>
11.1	Accessories	445
<b>12</b>	<b>Spare Parts</b>	<b>447</b>
<b>13</b>	<b>Waste disposal</b>	<b>449</b>
<b>14</b>	<b>Appendix A</b>	<b>451</b>
14.1	Glossary	451
<b>15</b>	<b>Appendix B</b>	<b>455</b>
15.1	Checklists	455
15.1.1	Annual Checklist	456
<b>16</b>	<b>Appendix C</b>	<b>465</b>
16.1	Installation Checklist	465
16.1.1	Shipping / Receiving	465
16.1.2	Mechanical Installation	465
16.1.3	Electrical Installation	466
16.1.4	Check Alignment of System	467
16.1.5	Calibration and Adjustments of Generator	468
16.1.6	Acceptance Tests	468
16.1.7	Remark	470
<b>17</b>	<b>Installation Report</b>	<b>471</b>
17.1	Attention	471

# Contents

---

# 1 Introduction

## 1.1 Document information

It is important to keep this document for the life of the equipment, and pass the document on to any subsequent holder or user of the equipment.

Training is provided by Arcoma AB. Training material is the Operation manual and the Installation and service manual.

### 1.1.1 System documentation

The following documentation is available for the system:

- OMNERA™ 400T Planning guide
- OMNERA™ 400T Installation and service manual
- OMNERA™ 400T Operator's manual

### 1.1.2 Stylistic conventions

All warning label texts are shown in *italic* style in this manual.

All references are shown in *italic* style in this manual.

### 1.1.3 Document producer

This document has been produced by:

Arcoma AB  
Annavägen 1  
S-352 46 VÄXJÖ,  
Sweden

[www.arcoma.se](http://www.arcoma.se)

### 1.1.4 Text emphasis



#### **WARNING!**

---

*All texts labelled with "WARNING" call attention to potential risk to health or life.*

---

#### **CAUTION!**

---

*All texts labelled with "CAUTION" contain information about dangerous situations and measures to avoid risk.*

---

#### **Note!**

---

*All texts labelled with "NOTE" contain additional information regarding the work step, and is provided for a better understanding or as a warning about unnecessary and avoidable difficulties.*

---

# Introduction

## Identification Labels

### 1.2 Identification Labels

The figure shows the location of the identification labels on the equipment.

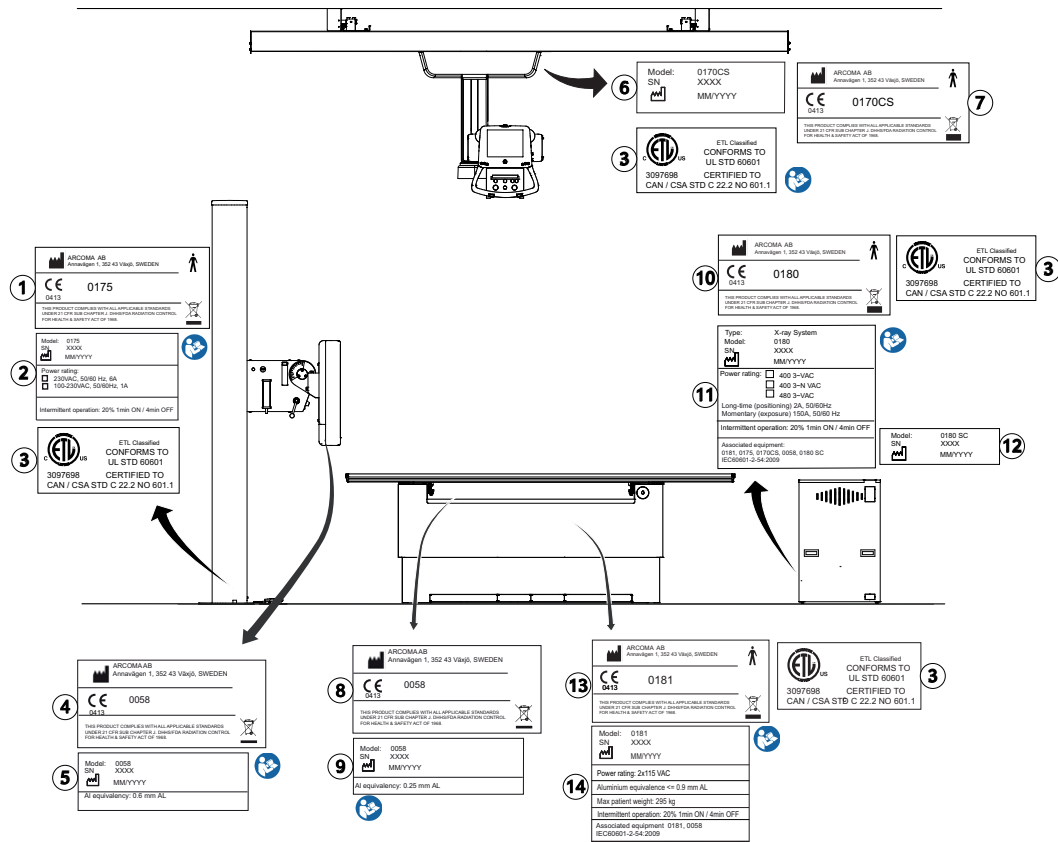

Fig. 1-1

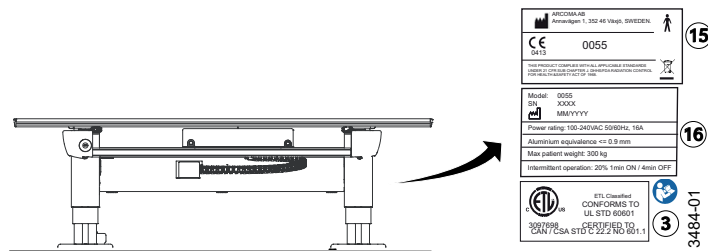

Fig. 1-2

# Introduction

## Identification Labels

Table 1-1 . Identification Labels

1		9	
2		10	
3		11	
4		12	
5		13	
6		14	
7		15	
8		16	

# Introduction

## System Description

---

### 1.3 System Description

#### 1.3.1 Intended use

The system is a stationary X-ray system, intended for obtaining radiographic images of various portions of the human body in a clinical environment.

The system is not intended for mammography.

#### 1.3.2 System Overview

The System may be configured in several different versions with a base consisting of an Image system, a cabinet and a ceiling system.

Starting with the base System, there is an option to include a Wallstand and/or a Table. There are two different Table options. The figure Fig. 1-3 *System Overview* shows the main parts of a System.

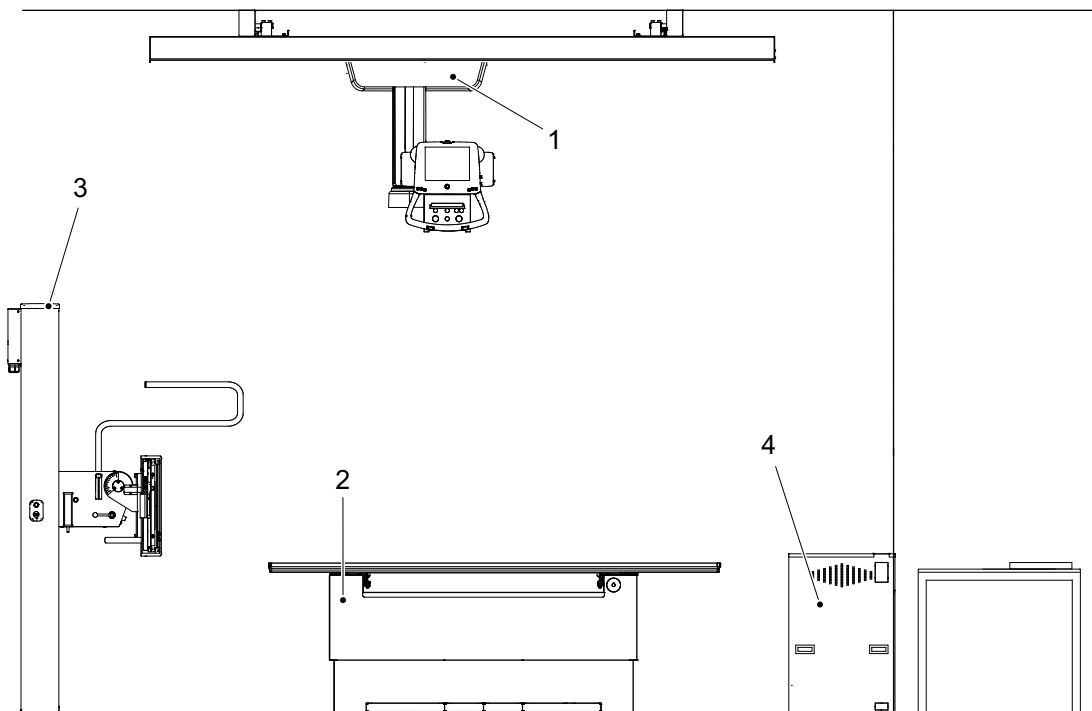

Fig. 1-3 System Overview

- |  |               |
|--|---------------|
| 1. Overhead Tube Crane (OTC)   | 3. Wall stand |
| 2. Table (Closed table 0181 Standard<br>or Two column table 0055 option) | 4. Cabinet    |

### 1.3.3 Overhead Tube Crane Overview

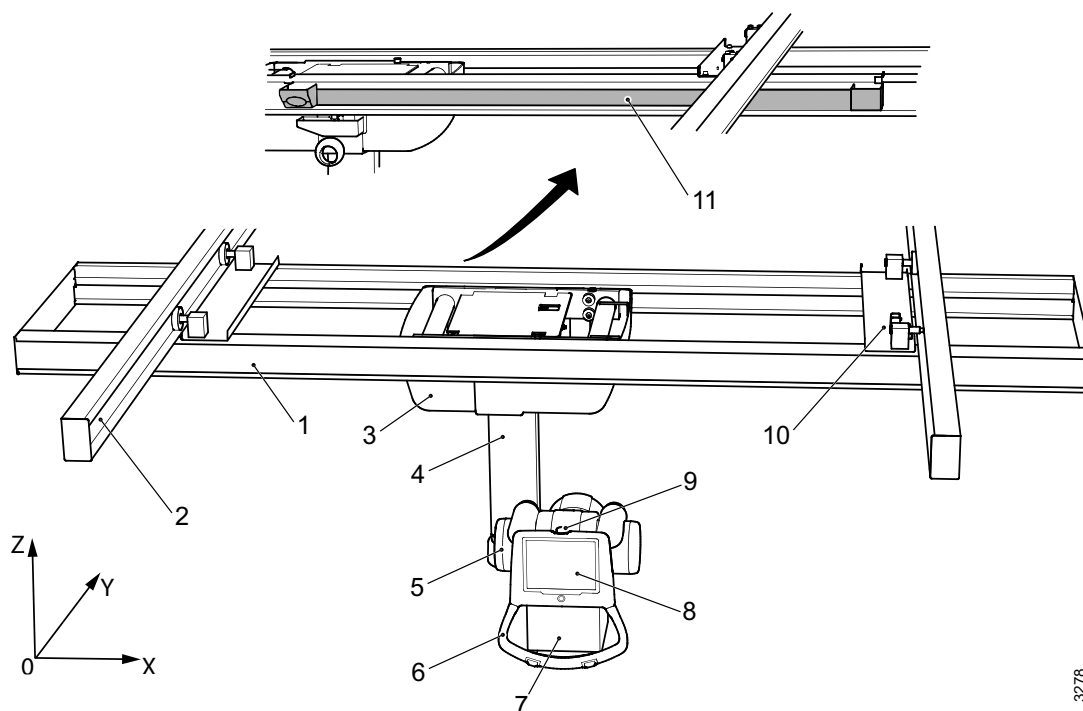

Fig. 1-4 Overview

- |                      |                              |
|----------------------|------------------------------|
| 1. Traverse rail (X) | 7. Collimator                |
| 2. Ceiling rail (Y)  | 8. Display                   |
| 3. Ceiling wagon     | 9. Emergency stop            |
| 4. Column (Z)        | 10. Distance plate and brake |
| 5. X-ray tube        | 11. Cable channel            |
| 6. Manoeuvre handle  |                              |

3278

# Introduction

## System Description

---

### 1.3.4 0181 Closed Table 0181 Overview

The figure shows the main parts of the closed table.

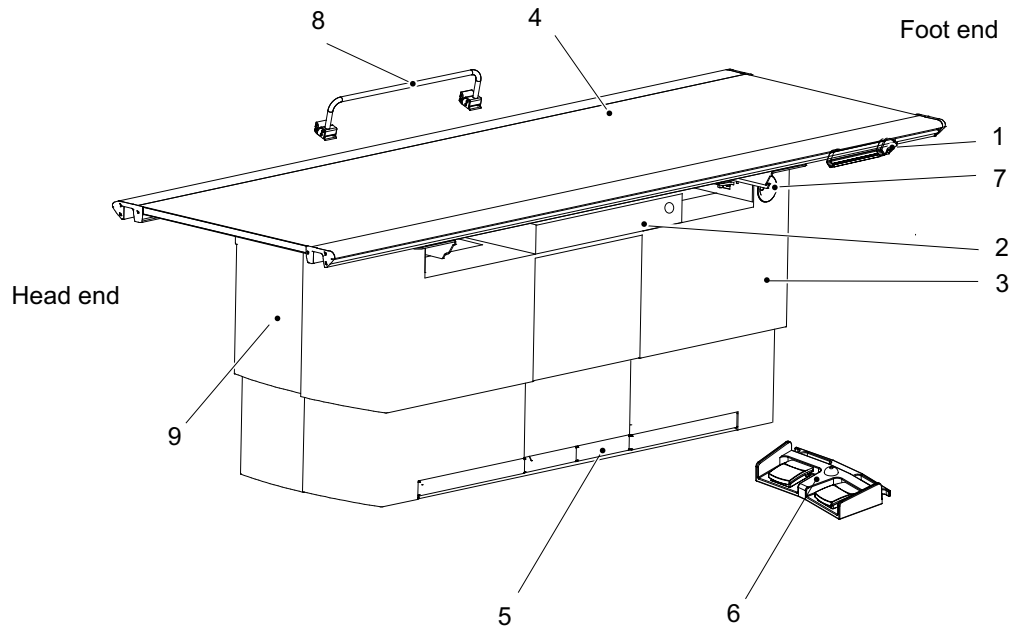

Fig. 1-5 Main parts closed table

- |                                     |   |
|-------------------------------------|---|
| 1. Maneuver hand control (optional) | 6. Foot control (optional)              |
| 2. Image receptor holder            | 7. Emergency stop                       |
| 3. Vertical lift                    | 8. Patient hand grip (optional)         |
| 4. Table top                        | 9. Cover segments for the vertical lift |
| 5. Kick box control                 |   |

#### 1.3.4.1 Intended Use, Closed Table 0181

The Table is intended for use in a hospital environment during radiographic diagnostic examinations, together with an X-ray tube support and an image receptor holder.

The Table is only intended to be used by trained radiographers, service technicians and product specialists

The main purpose of the Table is to supply the patient with a positioning support during a diagnostic examination and to make it possible to position the detector.

Other use of the closed table may result in potentially hazardous conditions to the operator and/or patient.



### 1.3.5 0055 Two Column Table 0055 Overview

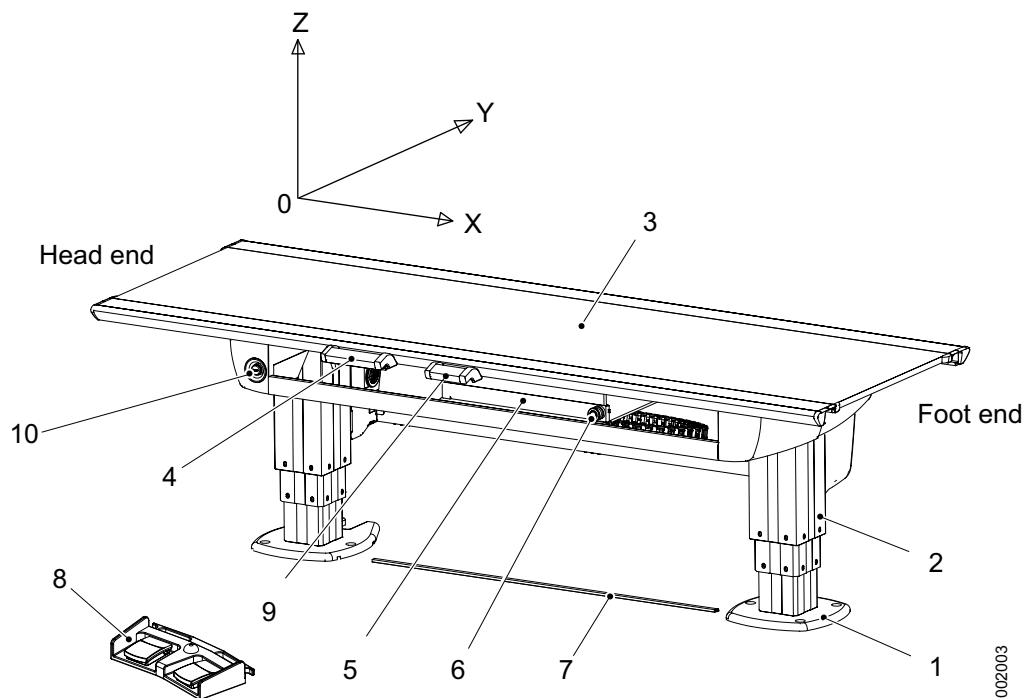

Fig. 1-6 Table overview

- |   |   |
|---|---|
| 1. Foot plate   | 6. Brake release button for detector holder |
| 2. Column   | 7. XY foot control strip type (option)      |
| 3. Table top (X/Y/Z)  | 8. Foot control table (X/Y/Z) (option)      |
| 4. Table hand control (X/Y/Z) Ceiling tube pendulum movement) | 9. Collimator hand control (option)         |
| 5. Detector holder  | 10. Emergency stop                          |

#### 1.3.5.1 Intended use, two column table 0055

The two column table is only intended to be used by trained radiographers, service technicians and product specialists.

The two column table is a flexible high performance patient support system that is intended to be used in X-ray systems for radiographic examinations.

The table is intended for use in a hospital environment during radiographic diagnostic examinations together with an X-ray tube support and a detector holder.

The main purpose of the table is to supply the patient with a positioning support during a diagnostic examination and to make it possible to position the detector.

Other use of the two column table may result in potentially hazardous conditions to the operator and/or patient.

The two column table can also be supplemented with external products, such as detectors, detector holders, grids, ion chambers and accessories supplied by Arcoma AB and intended for use with the Table 0055.

The design of the two column table allows a wide range of detectors, of various types and models, to be adapted to the system. The flexibility of the two column table also ensures extensive possibilities for customizing of functions and design.

# Introduction

## System Description

---

### 1.3.6 Wall Stand Overview

The figure shows the main parts of the wall stand.

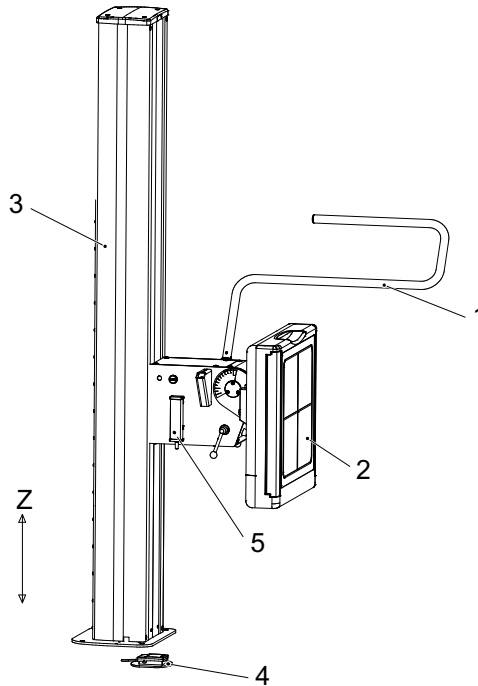

Fig. 1-7 Wall Stand Overview

- |  |  |
|--|--|
| 1. Lateral armrest<br>(Accessory)  | Optional Foot control (Motorized<br>movement; Z-movement up and<br>down and brake release) |
| 2. Imaging unit  |  |
| 3. Column  | 5. Hand control for collimator control<br>(Option)   |
| 4. Standard Foot control (Brake re-<br>lease for manually moving the de-<br>tector holder up/down) |  |

#### 1.3.6.1 Models and Designs

The Wall stand has different options:

- Tilttable detector holder wagon.
- Motorized Z movement.
- Prepared for different types of detectors; fixed or portable in different sizes.
- The detector/receptor holder for the portable detector is available for either left-hand or right-hand loading.

### **1.3.6.2 Intended Use, Wall stand**

The Wall stand is intended for use in a hospital environment during radiographic diagnostic examinations together with an X-ray tube support and a detector. The main purpose of the Wall stand is to hold and position the detector.

# Introduction

## System Description

---

## 2 Safety

### 2.1 Modification of equipment



**WARNING!**

*No modification of this equipment is allowed.*

---

### 2.2 Compliance

External equipment intended for connection to signal input, signal output or other connectors shall comply with the relevant product standard e.g. IEC 60950-1 for IT equipment and the IEC 60601-series for medical electrical equipment.

In addition, all such combinations – systems – shall comply with the safety requirements stated in the collateral standard IEC 60601-1-1 or the general standard IEC 60601-1, edition 3.1, clause 16. Any equipment not complying with the leakage current requirements in IEC 60601-1 shall be kept outside the patient environment i.e. at least 1.5 m from the patient support.

Any person who connects external equipment to signal input, signal output or other connectors has formed a system and is therefore responsible for the system to comply with the requirements.

If in doubt, contact qualified medical technician or your local representative.

If external equipment is connected, an isolation device is needed to isolate the equipment located outside the patient environment from the equipment located inside the patient environment. In particular such a separation device is required when a network connection is made. The requirements on the separation device is defined in IEC 60601-1-1 and in IEC 60601-1, edition 3.1, clause 16.

This product conforms to DHHS radiation Standards of 21 CFR subpart J as of the date of manufacture.

## 2.3 Precautions, Safety



**WARNING!**

---

*Do not use this device if you see smoke or notice unusual odors or noises.*

*If smoke, unusual odors or noise are being generated, continued use of this product may result in fire. Turn OFF the power source breaker immediately, unplug the device, and contact your nearest service representative. Do not attempt to repair it.*

---



**WARNING!**

---

*Although the precautions indicated on this device or in this document or device Manuals are provided based on various considerations, unpredictable events may still occur.*

*While operating this product, pay constant attention to possible hazards in addition to observing the instructions.*

---



**WARNING!**

---

*The equipment is intended for use in radiographic examinations and under the guidance of trained health care professionals. Operating personnel must be familiar with the equipment and the instructions given in this Manual before using the equipment.*

---



**WARNING!**

---

*Safety devices must not be removed or modified. Any modification or removal will immediately impair the safety.*

---

**CAUTION!**

---

*After using the device, return the switches and dials to the original positions using the specified procedures, and turn the power OFF.*

---

**CAUTION!**

---

*Do not use any flammable or explosive gases near the device.*

---

**CAUTION!**

---

*Before using this device, read the Manuals supplied with the devices in order to understand functions, operation, and performance. Follow the Manuals for correct procedures.*

---

# Safety

## Precautions, Safety

---

**CAUTION!**  
*Before using the device again after a prolonged discontinuance, check that the equipment operates correctly and safely.*

---

**CAUTION!**  
*Be sure to observe the precautions indicated on this device or in this document or device Manuals. Failure to observe them can cause personal injury or damage to this device.*

---

**CAUTION!**  
*While using the device, always keep an eye on all devices and patients in order to detect unfavorable conditions.*

---

**CAUTION!**  
*The System is provided with air intakes and outlets to prevent the equipment from overheating. Do not block these air intakes and outlets.*

---

**CAUTION!**  
*When operating this device, be sure to follow the instructions and procedures described in this document and the device Manuals.*

---

**CAUTION!**  
*Always be careful, when handling loose objects so they will not fall down on patient or at the surrounding articles. This may cause injury to the patient or damage at the System.*

---

**CAUTION!**  
*When using this device, be sure to observe the installation environment requirements (temperature, humidity, and power rating conditions, or restriction of use near a device generating strong magnetic or electromagnetic waves).*

---

**CAUTION!**  
*The installation environment and location, device configuration, network, power supply, and other conditions are optimized for this device. If you want to change any condition, contact your nearest service representative. Otherwise, the functions and performance of this device may be impaired.*

---

**CAUTION!**  
*Preferably, no objects shall be positioned within the working area. If this is necessary, they must be removable.*

---



**CAUTION!**

*Do not put liquids, or foreign objects such as pins and clips into the equipment. Otherwise, fires, electric shocks, or malfunctions may result. If any foreign objects have fallen into the equipment, turn OFF the power source breaker immediately and unplug the equipment. Contact your nearest service representative.*

*Never disassemble the device.*

---

**CAUTION!**

*The display must not be used for diagnostic purposes.*

---

**CAUTION!**

*If cracking or breakage occurs on the display, immediately stop using it. Never use it when the display is damaged.*

---

**CAUTION!**

*If the touch panel is broken, and the liquid inside it is leaked, do not put it into your mouth. If the liquid is put on the part of your body or clothes, immediately wash it off in soapy water.*

---

**Note!**

*The following radio interference standards apply to this equipment: Voluntary Control Council for Information Technology Equipment (VCCI) Class B.*

---

**Note!**

*The following radio interference standards apply to this equipment: Federal Communications Commission (FCC) Part 15 Class B.*

---

# Safety

## Qualifications of personnel

---

### 2.4 Qualifications of personnel



#### **WARNING!**

---

*The equipment is intended for use in radiographic examinations under the guidance of trained health care professionals. Operating personnel must be familiar with the equipment and the instructions given in this manual before using the equipment.*

---

#### **CAUTION!**

---

*Federal law restricts this device to be sold by or on the order of a physician.*

---

#### **2.4.1 Operating personnel**

Before using the product it is required that the operating personnel is thoroughly familiar with the product and its operating instructions, in particular:

- Safety
- Function and safety check list

#### **Note!**

---

*It is the responsibility of the owner to ensure that the product is operated only by trained radiologist, service technicians or product specialists.*

---

#### **2.4.2 Service personnel**

The equipment shall be serviced only by qualified personnel who:

- is completely familiar with the system
- has read and understood *Operation Manual* and *Installation and Service Manual*.
- knows how to remove power to the unit in case of an emergency
- is trained in the use of equipment and procedures of this type.

Failure to follow the instructions given in this Manual could result in serious injury to the service person, patient and operator.

#### **Note!**

---

*It is the responsibility of the owner to ensure that the technicians have the correct training and knowledge to perform service and maintenance.*

---

## 2.5 Service and Maintenance



**WARNING!**

---

*Always turn off the power and lock the main switch before service or maintenance.*

---



**WARNING!**

---

*No service is allowed while the system is in use with a patient.*

---

**Note!**

---

*When service or maintenance will be performed, the technician shall lock the equipment from all energy sources.*

---

The equipment must be checked according to the *Function and Safety Checks Instructions* to maintain reliability and serviceability, and to ensure the safety of the patients, the operator and third parties.

If national rules or regulations specify more frequent checks and/or maintenance, such regulations must be observed.

# Safety

## Installation and repair

---

### 2.6 Installation and repair



#### **WARNING!**

---

**To avoid risk of electric shock, this equipment must only be connected to a supply mains with protective earth.**

---

#### **CAUTION!**

---

**Only service technicians are allowed to open the covers.**

---

#### **CAUTION!**

---

**Do not remove, disassemble, change, modify, repair, or add any part.**

---

#### **CAUTION!**

---

**When installing this equipment in a different location, contact the manufacturer or the designated dealer.**

---

#### **Note!**

---

*For exchange of the collimator light field lamp, see the Collimator manual.*

---













Modifications of, or additions to, the product must be made in accordance with the legal regulations and generally accepted engineering standards.

The manufacturer cannot assume responsibility for the safety features and for the reliability and performance of the equipment, if:

- installation of equipment expansions or modification are not approved by the manufacturer.
- installation of equipment expansions or modification are not carried out by persons authorized by the manufacturer.
- components are not replaced by original spare parts in case of a malfunction.
- the electrical installation of the room concerned does not meet the requirements or the corresponding national regulations.
- the product is not used in accordance with the operating instructions.

### 2.7 Safety and Warning Symbols

The following symbols are used for the product.

	Attention consult accompanying documents.
	To signify a general warning. This symbol is used in various places throughout the Manual where special precaution shall be observed.
	Type B applied part.
	Protective earth terminal.
	Earth terminal.
N	Connection point for the neutral conductor on permanently installed equipment.
	Squeezing hazard.
	This symbol indicates compliance of the equipment with Directive 93/42/EEC.
	Separate collection for electrical and electronic equipment.
	Manufacturer
	Manufacture date producer
	To indicate the emission or the imminent emission of X-radiation.
	Marking on the emergency stop button. Activation of the actuator interrupts all mechanical movements and prohibits exposures.

# Safety

## Safety and Warning Labels on the Equipment

### 2.8 Safety and Warning Labels on the Equipment

**! WARNING!**

**Table;**

**Squeezing hazard can occur between the:**

- **Table top and the top of the detector holder**
- **Detector holder rail and the detector holder**
- **Vertical lift segments when moving in Z-direction down**

The figures shows the location of the safety and warning labels.

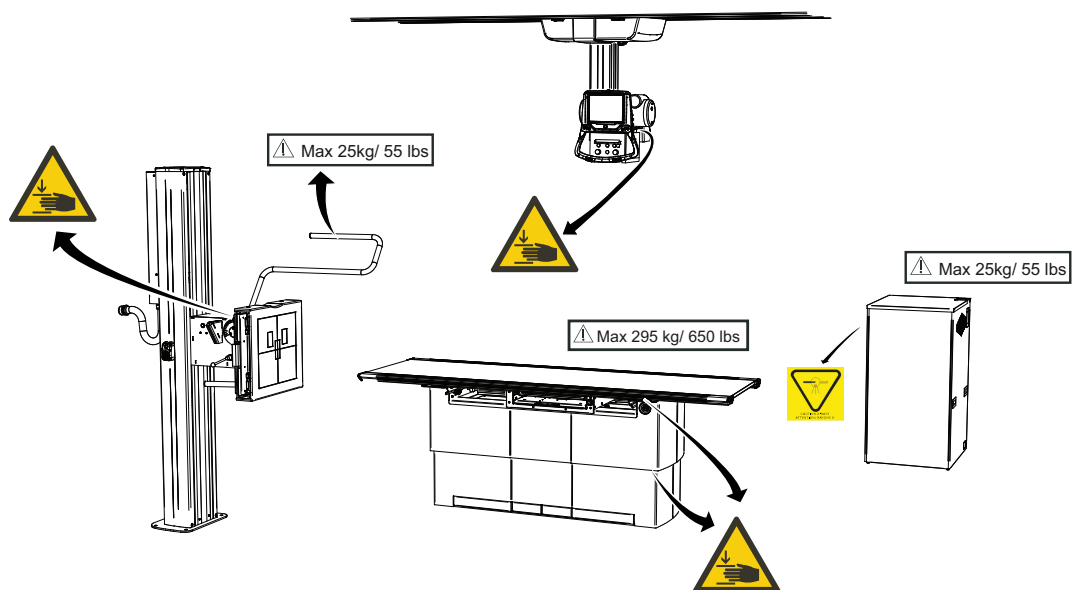

Fig. 2-1 Location of the Safety and Warning labels, with table 0181

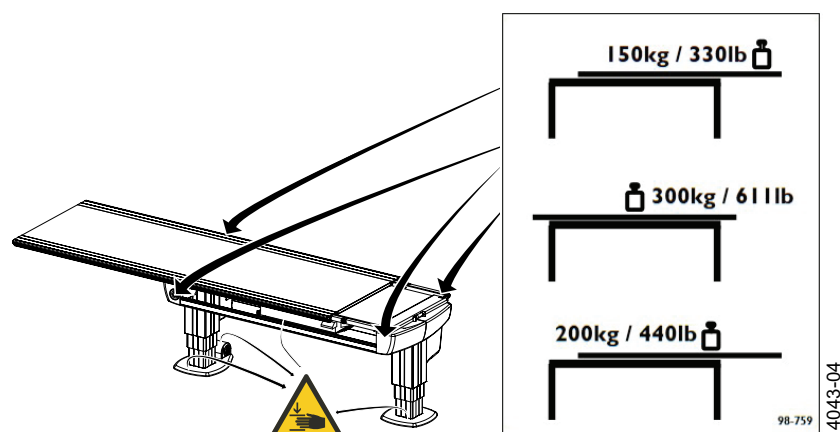

Fig. 2-2 Location of the weight restriction labels and warning labels, table 0055

Possible squeeze hazard areas are indicated in the figures above.

### 2.9 Emergency Stop

**Note!**

*It is recommended to train the operator regularly in the use of the emergency stop function so the operator feels confident in using it.*

The System has five emergency stops; one on the Ceiling suspended X-ray tube support, two on each side of the Table (at the head end), and two on the wall stand.

Pressing one of the emergency stop buttons, immediately cuts the power to all motorized movements. The emergency stop is also connected to the generator. The emergency stop will prevent a new exposure and terminate an ongoing exposure.

To reset the emergency stop position, turn the emergency stop button clockwise. The button is released and the system is ready for use again.

There are additional external emergency stops as option.

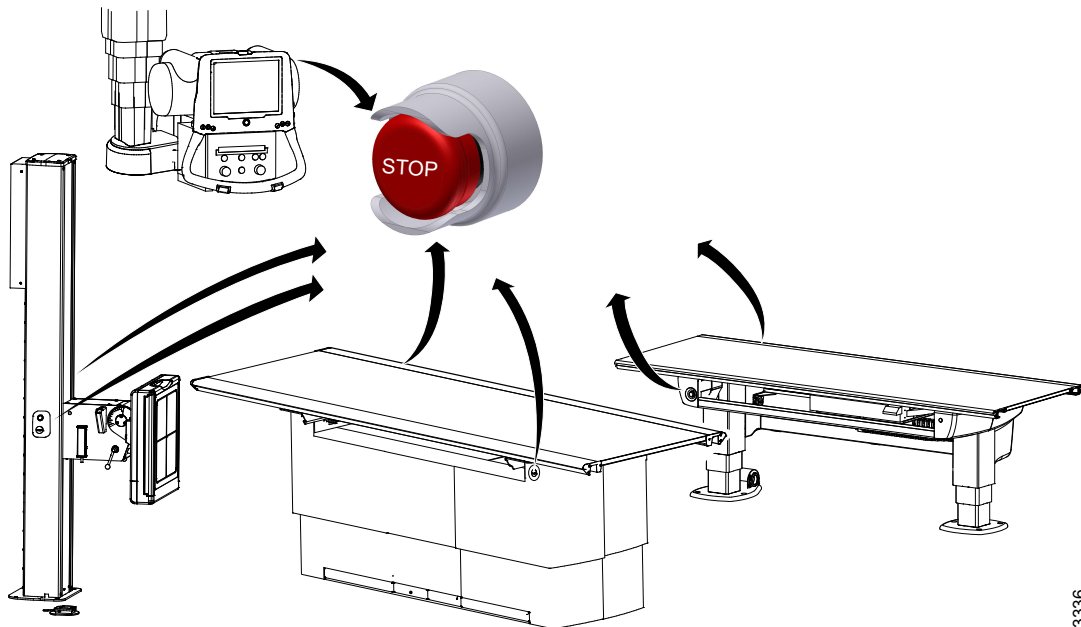

Fig. 2-3 Emergency Stop Positions

3336

# Safety

## Radiation and X-ray Tube

---

### 2.10 Radiation and X-ray Tube



**WARNING!**

*Make sure that the patients, the operators and third parties are protected against unnecessary X-ray radiation according to the local regulations.*

---



**WARNING!**

*The surfaces on the Collimator and the X-ray tube can be warm. The collimator temperature will not reach 60 degrees Celsius, but the X-ray tube may be up to 85 degrees Celsius.*

---



**WARNING!**

*Verify that correct filter is used during exposure.*

---



**WARNING!**

*Make sure that the SID shown in the display corresponds to that shown on the collimator.*

---

**Note!**

*Audio and visual communication must be possible between the operator and the patient when exposure is performed.*

---

**Note!**

*The X-ray beam must never be outside the boundaries of the detector holder.*

---



## 2.11 Mechanical Safety



**WARNING!**

*Tracking is only allowed under supervision of personnel.*

---



**WARNING!**

*Squeezing hazard can occur between column segments and beta rotational assembly interface.*

---



**WARNING!**

*Squeezing hazard can occur between the column and the plastic corner around the alpha movement.*

---



**WARNING!**

*Squeezing hazard can occur between support arm and high tension cable inlet to the tube.*

---



**WARNING!**

*All obstacles placed within the working area, must be moveable for easy patient release. This is necessary due to the squeezing hazard.*

---

**Note!**

*Surrounding equipment are not subject of the collision warning.*

---

### 2.11.1 General

It is the operator's duty to ensure that any danger to the patient and/or third person is prevented, before movements are released.

# Safety

## Mechanical Safety

---

### 2.11.2 OTC, Mechanical Safety



#### **WARNING!**

---

*Make sure that the personnel who are trained in the use of the equipment are beside the patient for support, to avoid any potential risk of injury when handling the OTC, for example squeezing between the Wallstand/Table.*

---



#### **WARNING!**

---

*All motorized movements shall be supervised by trained personnel.*

---

#### **CAUTION!**

---

*The IR sensor underneath the Ceiling stand is exclusively intended for Table protection. It is not intended for patient protection.*

---

Possible squeezing hazard areas are indicated in Fig. 2-4 *Mechanical Safety*.

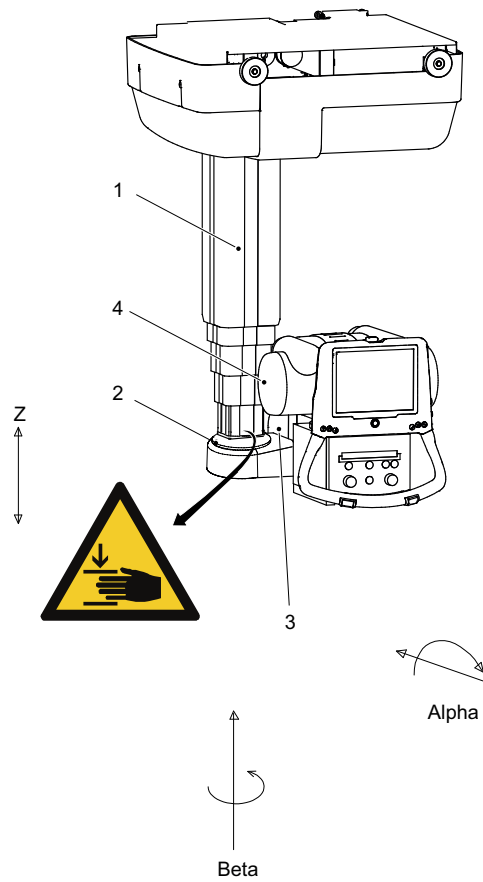

Fig. 2-4 Mechanical Safety

- |                        |               |
|------------------------|---------------|
| 1. Column (Z)          | 3. Cover      |
| 2. Column bottom plate | 4. X-ray tube |

Squeezing hazard can occur between the:

- column (1) and the column bottom plate (2) when the column is moving upward (Z-direction).
- cover (3) and the column (1) when the X-ray tube (4) is moving in beta direction.

# Safety

## Mechanical Safety

---

### 2.11.3 Mechanical Safety, Table

#### 2.11.3.1 Safety Issues when Placing the Patient, Table



**WARNING!**

*The hospital bed shall be placed in direct contact and in the same height as the Table, to avoid any potential risk of injury during transfer of the patient.*

---



**WARNING!**

*Due to squeezing hazards, the patient shall always have their extremities placed over the table top.*

---



**WARNING!**

*Be aware of unwanted motion when releasing the brakes.*

---



**WARNING!**

*To avoid any potential risk of injury when handling the product. Make sure that personnel trained in the use of the equipment, is at the side of the patient for support.*

---



**WARNING!**

*If a fully extended table top is subject to extreme forces laterally, there is a risk for damage to the floor attachment. Contact the Manufacturer for further information about the attachments.*

---

**Note!**

*Do not lean against the table top when the table top is floating.*

---



### **WARNING!**

**Squeezing hazard can occur between the:**

- **table top and the top of the detector holder**
- **table top and the detector holder rail**
- **detector holder rail and the detector holder**
- **detector holder and the cover**
- **vertical lift segments when moving down in Z-direction (closed table)**
- **columns and the footplate (two column table)**
- **cover and the column foot cover**
- **detector holder and vertical lift segment**

Possible squeezing hazard areas and placement of warning labels:

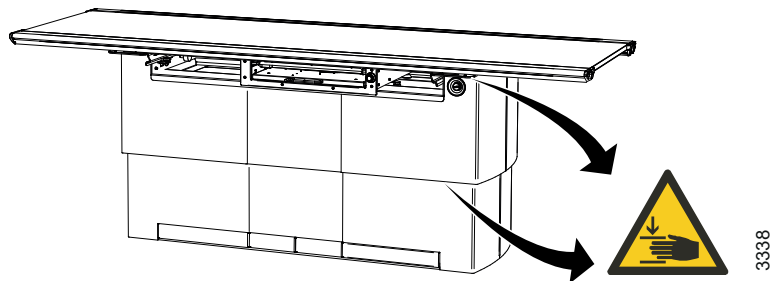

Fig. 2-5 Closed table 0181

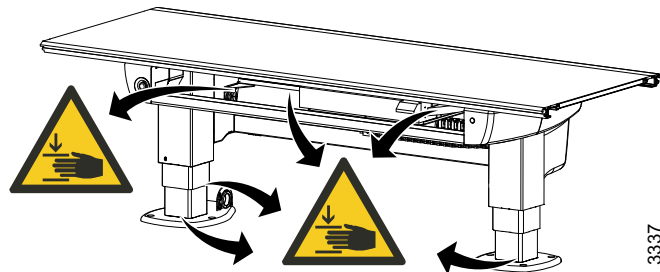

Fig. 2-6 Two column table 0055

# Safety

## Mechanical Safety

---

When transferring the patient from the hospital bed to the X-ray Table, the table top has to be locked and centered over the Table. To avoid any potential risk of injury during transfer of the patient the hospital bed shall always be placed in direct contact and in the same height as the X-ray Table.

To reduce the lateral forces on the Table the operator shall be placed on the opposite longitudinal side of the patient and the hospital bed. The operator shall then drag the mattress with the patient from the hospital bed to the x-ray Table.

**Note!**

*Wheelchair patients shall always be placed outside the working area, when operating any motorized movement.*

---

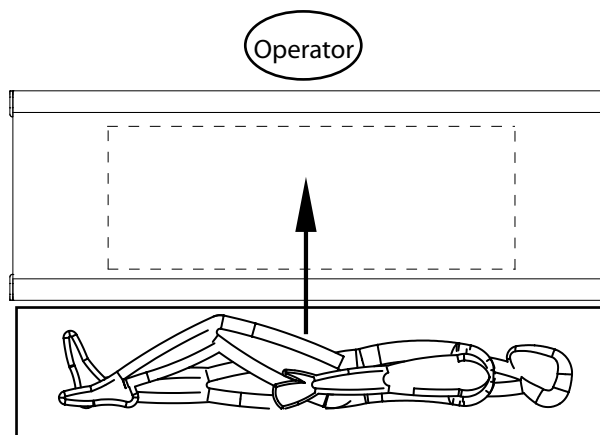
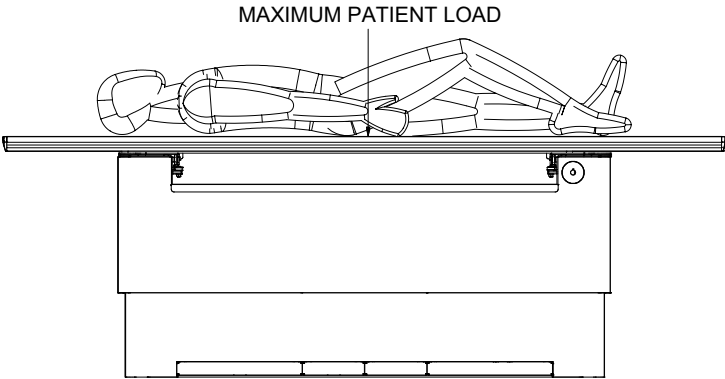

*Fig. 2-7 Transferring patient to Table*

The figure shows the placement of the table top, the operator and the patient when transferring the patient to the X-ray Table.

When transferring the patient back to the hospital bed, the operator shall be placed in the opposite place near the hospital bed.

**2.11.3.2 Weight Restrictions Table 0181**



*Fig. 2-8 Maximum patient load, patient centered*

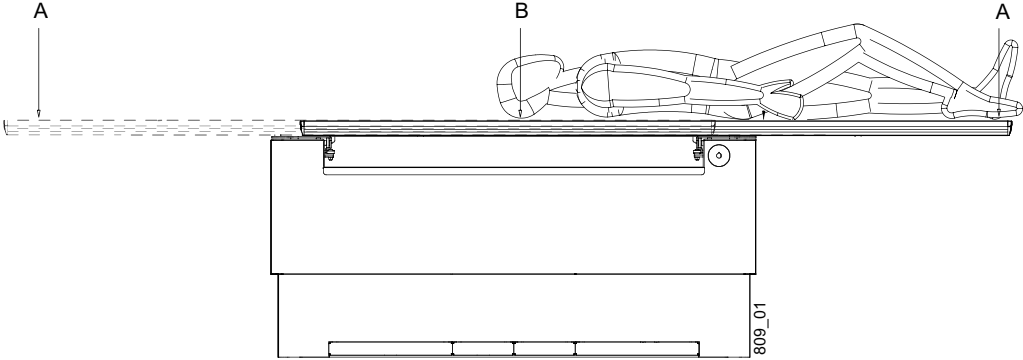

*Fig. 2-9 Maximum patient load, position A – B*

*Table 2-1*

<b>Pos.</b>	<b>Model 0181-1</b>
A	200 kg / 440 lb
B	295 kg / 650 lb

# Safety

## Mechanical Safety

### 2.11.3.3 Weight Restrictions Table 0055

The following figures show the maximum load at different positions of the table.

When the table top is centered over the table frame, the maximum load of a patient either lying or sitting is 300 kg/ 611 lb, see Fig. 2-10 *Maximum patient load, patient centered*

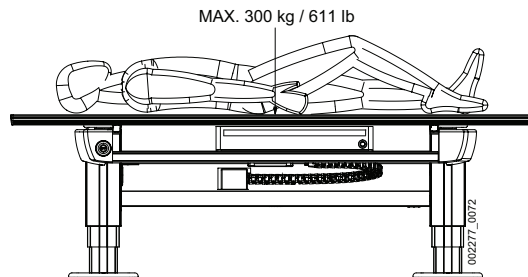

Fig. 2-10 *Maximum patient load, patient centered*

When the table top is positioned outside the table frame, the maximum load of a patient lying on the table top is 200 kg/ 440 lb and the maximum load of a patient sitting on the table top is 150 kg / 330 lb.

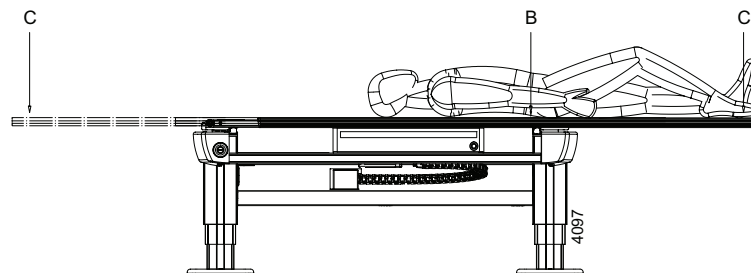

Fig. 2-11 *Maximum patient load position B – C*

Table 2-2

Pos.	Model 0055
B	200 kg / 440 lb
C	150 kg / 330 lb

The table frame is marked on the upper side with the maximum weight when positioning in outer positions, see Fig. 2-12



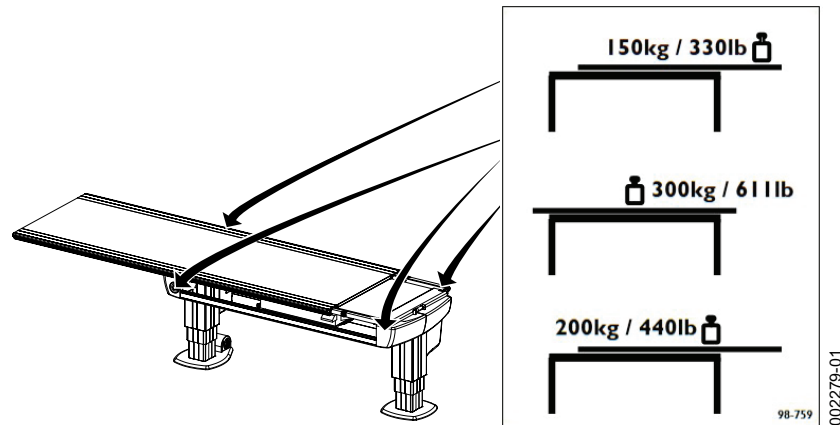

Fig. 2-12

#### 2.11.3.4 Working Area, Table 0181



#### **WARNING!**

*Due to squeezing hazard, when operating any motorized movement — when not placed on the Table — patients shall always be outside the working area.*



#### **WARNING!**

*All obstacles placed within the working area, must be moveable for easy patient release. This is necessary due to the squeezing hazard.*

#### **CAUTION!**

*To avoid any injuries to patient, user or System, peripherals should always be placed outside the working area.*

The working area is the size of the table top including the stroke length of the table top in the X- and Y-direction. The measurements in the figure show the length of stroke in the X- and Y-direction. The dimensions have some tolerances and can differ from the Manufacturer.

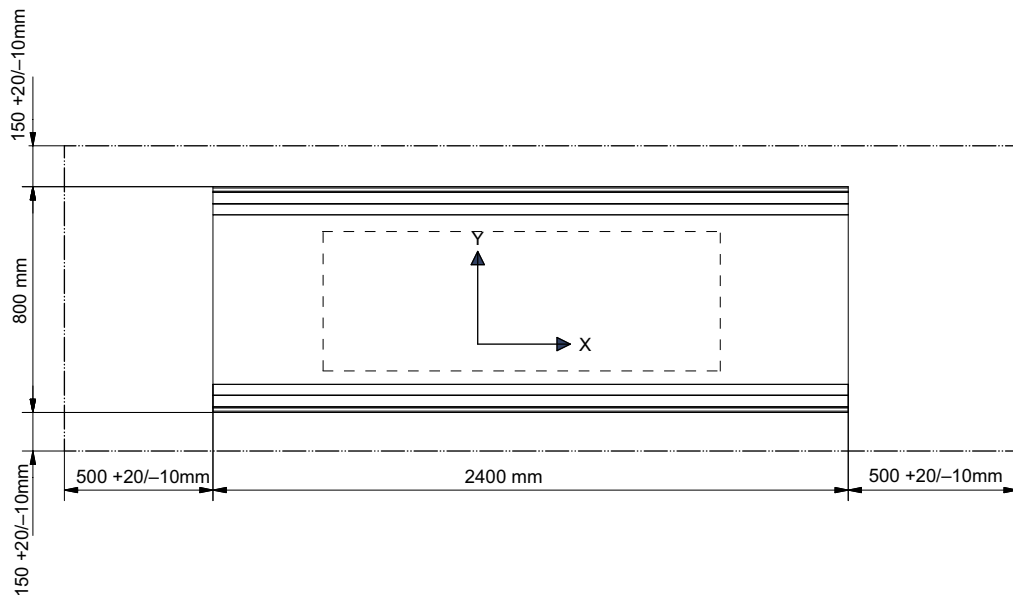

Fig. 2-13 Stroke length

The figure below shows the dimension underneath the Table

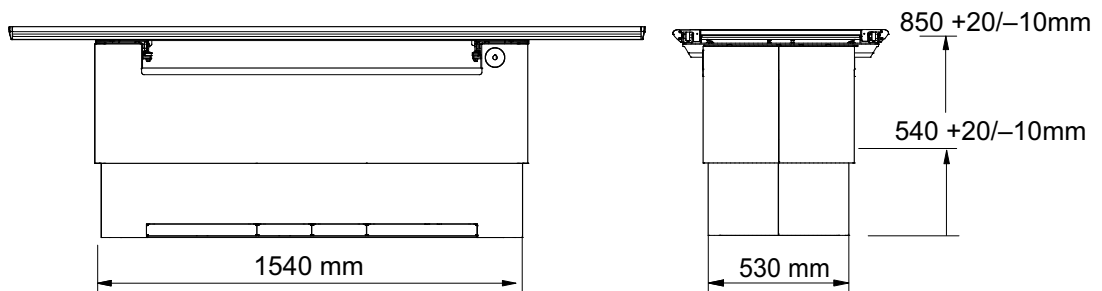

Fig. 2-14 Dimensions underneath the Table

**Area for the Detector holder**

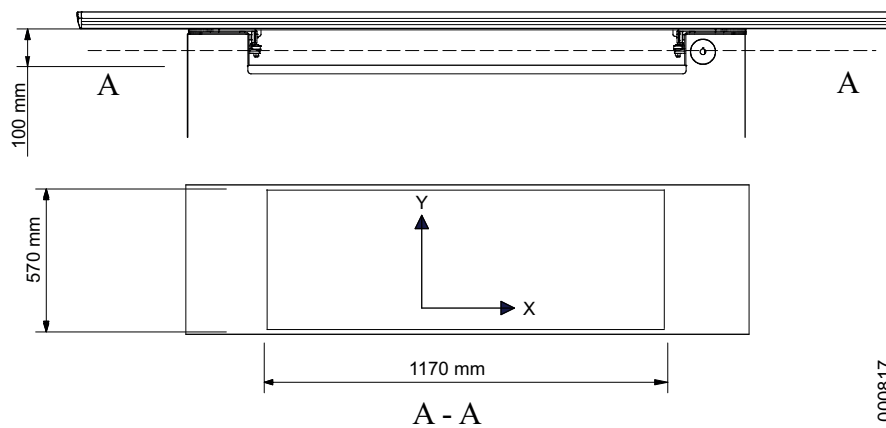

Fig. 2-15 Dimensions

000817

### 2.11.4 Working area, Table 0055



**WARNING!**

**Due to squeezing hazard, when operating any motorized movement — when not placed on the table — patients shall always be outside the working area.**

The working area is the size of the table top, including the length of stroke of the table top in the X- and Y-direction.

The measurements in Fig. 2-16 show the length of the stroke in the X- and Y-direction.

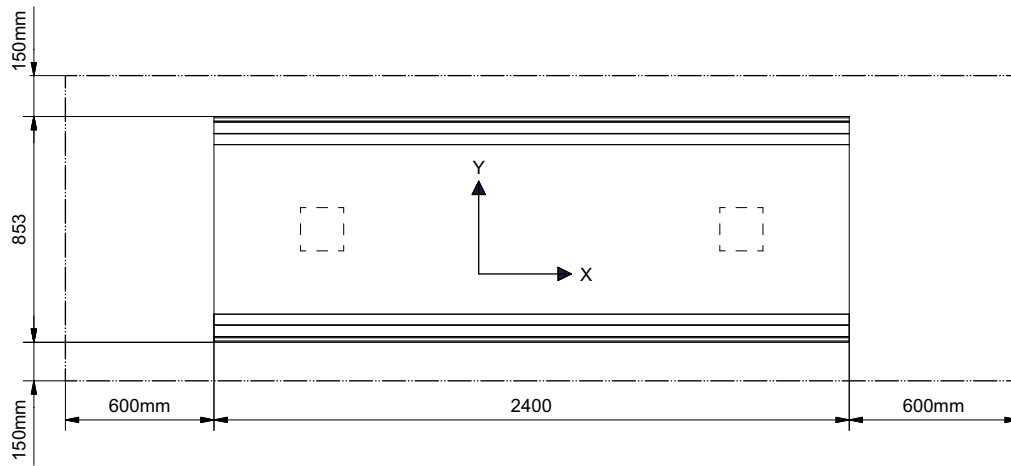

Fig. 2-16

The Fig. 2-17 shows the dimensions underneath the table

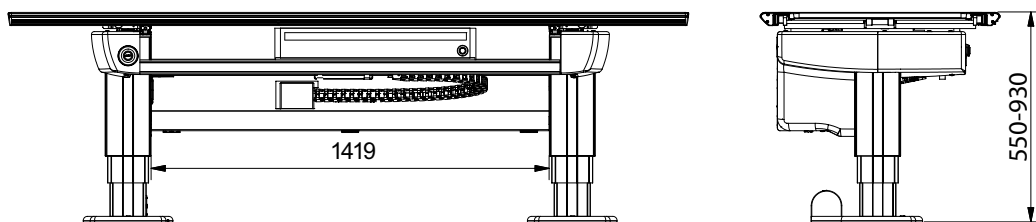

Fig. 2-17

# Safety

## Mechanical Safety

---

### 2.11.5 Mechanical Safety, Wall Stand

#### Note!

The patient or operator is allowed to lean against the Wallstand patient handle or armrest, but **not** to put any weight on it.

---

#### 2.11.5.1 General

It is the operator's duty to ensure that any danger to the patient and/or third person is prevented, before movements are released.

#### 2.11.5.2 Standard Version

Possible squeeze hazard areas are indicated in figure. Getting stuck in the imaging unit slide opening (1) causes squeezing hazard if the imaging unit is moving downward (Z-direction).

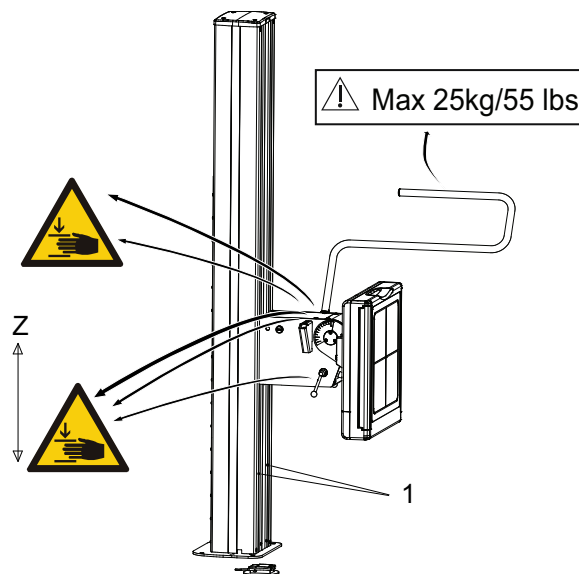

Fig. 2-18 Possible squeeze hazards

1. Slide opening of the imaging unit

#### 2.11.5.3 Motorized Wall stand

#### **CAUTION!**

**It is not allowed to have the patient sitting or standing in the wall stand surroundings, when the motorized movement is operated.**

---

## 2.12 Safety Functions

### 2.12.1 System

#### 2.12.1.1 Collision Detection

##### *Opposite Buttons Pressed*

If, at any time, two from each other opposite buttons are pressed, for example movements up and down, the movement is stopped. Both buttons must be released before any movement is allowed.

#### 2.12.1.2 Dead Man's Grip

All movements require constant activation of the chosen button.

If the operator releases one of the buttons/controls, the System will immediately stop or engage the brakes (manual movements). The exposure hand control has the same functionality.

#### 2.12.1.3 PID Controller

The control loop is implemented as a PID-controller with both acceleration and velocity feed forward. The function of the anti-windup is to prevent any increase of the integration part when the driver board limits the output voltage to a value less than the desired output voltage.

### 2.12.1.4 Safety Functions Table

#### ***Table 0181 Top Crash Guard***

The table top crash guard shall only be primarily used as a safety precaution for the System, but will as well limit the risk of personal injury, although the crash guard does not guarantee patient protection.

To be able to detect a collision, four micro switches are placed between the Table and the table top. If the Table crashes into an object, the micro switches will stop the movement in the on-going direction, but it will allow the movement in the opposite direction. When the object is removed, the Table can move in both directions again.

At power-up, the Table will detect if a button is activated, and then disable all movements. If that is the case, switch off the power and remove the obstacle/replace the broken switch.

#### ***Table 0055 Top Crash Guard***

The table top crash guard is primarily used as a safety precaution for the System (Table top) but will of course limit the risk of personal injury as well, although the function does not guarantee the accuracy needed for patient protection.

To be able to detect a collision, four load cells are mounted between the table frame and the columns. The sensor produces an analogue signal to an input on the guard board. The guard board amplifies the signal and checks if the value is within the specified range. If the signal is not within range the guard board activates an output, which activates a relay and the movement will stop.

The table top crash guard act as a vertical travel safety system protecting the table top. It activates if a collision is detected and the force exceed 20 kg, all movements are stopped

### **Indication of Power to the Table 0181/0055**

The device is powered when the green indicator light on the table frame is lit. See position A in the figure below.

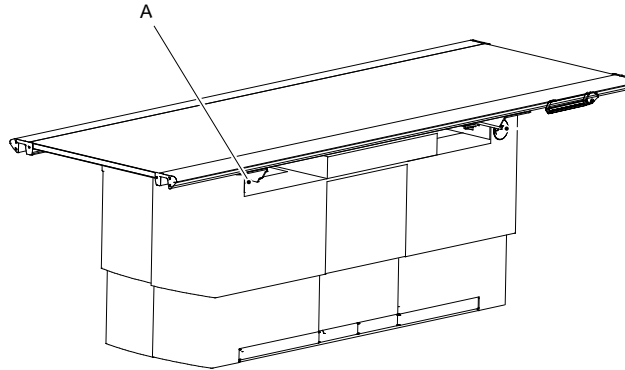

Fig. 2-19 Power indication Table 0181

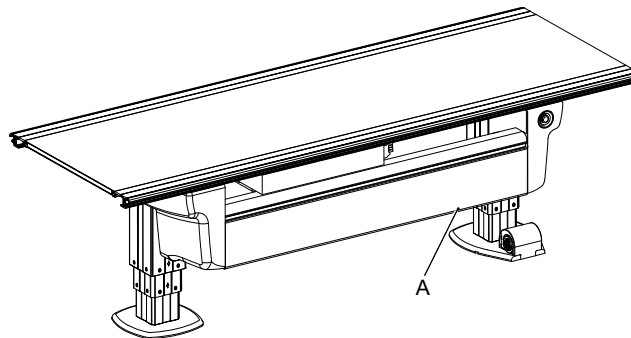

Fig. 2-20 Power indication Table 0055

### **2.12.1.5 Wall stand**

#### **Manual Wall stand**

The Wall stand is strictly manually controlled. All movements are balanced which means that very little force needs to be applied. To move the system up or down, the brake has to be released, by pressing constantly and pushing the image receptor holder manually up or down.

The product is balanced with counterweights and whenever any item is removed from the Wall stand it will become unbalanced. If the brake is released when the Wallstand is unbalanced, the image receptor holder will move upward and can cause injury.



#### **WARNING!**

---

**Be aware of unwanted motion when releasing the brakes.**

---

#### **Motorized Wall stand**

##### **Collision Detection**

Every motorized movement has a collision detection. All movements are stopped when the collision detection activates and the display shows an error message.





### 2.13.2 Safety Zone, Wall stand

When the alpha angle is outside the range of +45 degrees to –45 degrees, the automatic movement downward (tracking) is possible in safety zone (1).

The safety zone (1) does not affect the function of the automatic movement upward (tracking).

# Safety

## Electromagnetic Compatibility (EMC)

### 2.14 Electromagnetic Compatibility (EMC)

The System complies with the requirements of IEC 60601-1-2:2007 regarding electromagnetic compatibility. Surrounding equipment shall follow the standard IEC 60601-1-2:2007.

**CAUTION!**

**Do not place this device near MRI equipment or other equipment that generates a strong magnetic field.**

**CAUTION!**

**Mobile telephones and other radiating equipment can interfere with the function of the System and can therefore cause safety hazards.**

Guidance and manufacturer's declaration - electromagnetic emissions		
The System is intended for use in the electromagnetic environment specified below. The customer or the user of the System should assure that it is used in such an environment.		
Emissions test	Compliance	Electromagnetic environment - guidance
RF emissions CISPR 11	Group 1	The System uses RF energy only for its internal function. Therefore, its RF emissions are very low and are not likely to cause any interference in nearby electronic equipment.
RF emissions CISPR 11	Class B	The System is suitable for use in all establishments, other than domestic and those directly connected to the public low-voltage power supply network that supplies buildings used for domestic purpose. For information purpose the System complies with IEC61000-3-11 and is suitable for connection to public mains network if the impedance is 0.32 Ohm or lower
Harmonic emissions IEC 61000-3-2	Not applicable	
Voltage fluctuations/ Flicker emissions IEC 61000-3-3	Not applicable	

Guidance and manufacturer's declaration - electromagnetic immunity			
The System is intended for use in the electromagnetic environment specified below. The customer or the user of the System should assure that it is used in such an environment.			
Immunity test	IEC 60601 test level	Compliance level	Electromagnetic environment - guidance
Electrostatic discharger (ESD) IEC 61000-4-2	± 6 kV contact ± 8 kV air	± 6 kV contact ± 8 kV air	Floors should be wood, concrete or ceramic tile. If floors are covered with synthetic material, the relative humidity should be at least 30%.
Electrical fast transient/burst IEC 61000-4-4	± 2 kV for power supply lines + 1 kV for input/output lines	± 2 kV for power supply lines n/a. for input/output lines	Mains power quality should be that of a typical commercial or hospital environment.

# Safety

## Electromagnetic Compatibility (EMC)

<b>Guidance and manufacturer's declaration - electromagnetic immunity</b>			
Surge IEC 61000-4-5	± 1 kV differential mode  ± 2 kV common mode	± 1 kV differential mode  ± 2 kV common mode	Mains power quality should be that of a typical commercial or hospital environment.
Voltage dips, short interruptions and voltage variations on power supply input lines. IEC 61000-4-11	<5 % $U_T$ (>95 % dip in $U_T$ ) for 0.5 cycle  40 % $U_T$ (60 % dip in $U_T$ ) for 5 cycles  70 % $U_T$ (30 % dip in $U_T$ ) for 25 cycles  <5 % $U_T$ (>95 % dip in $U_T$ ) for 5 sec	<5 % $U_T$ (>95 % dip in $U_T$ ) for 0.5 cycle  40 % $U_T$ (60 % dip in $U_T$ ) for 5 cycles  70 % $U_T$ (30 % dip in $U_T$ ) for 25 cycles  <5 % $U_T$ (>95 % dip in $U_T$ ) for 5 sec	Mains power quality should be that of a typical commercial or hospital environment. If the user of the System requires continued operation during power mains interruptions, it is recommended that the System should be powered from an uninterrupted power supply or battery.
Power frequency (50/60 Hz) magnetic field IEC 61000-4-8	3 A/m	3 A/m	Power frequency magnetic fields should be at levels characteristic of a typical location in a typical commercial or hospital environment.
<p><b>Note!</b> —</p> <p><math>U_T</math> is the AC mains voltage prior to application of the test level.</p>			

# Safety

## Electromagnetic Compatibility (EMC)

Guidance and manufacturer's declaration - electromagnetic immunity			
The System is intended for use in the electromagnetic environment specified below. The customer or the user of the System should assure that it is used in such an environment.			
Immunity test	IEC 60601 test level	Compliance level	Electromagnetic environment - guidance
			Portable and mobile RF communications equipment should be used no closer to any part of the System, including cables, than the recommended separation distance, calculated from the equation applicable to the frequency of the transmitter.  Recommended separation distance;
Conducted RF IEC 61000-4-6	3 Vrms 150 kHz to 80 MHz	3 Vrms 150 kHz to 80 MHz	$d = 1.2 \sqrt{p}$
Radiated RF IEC 61000-4-3	3 V/m 80 MHz to 2.5 GHz	3 V/m 80 MHz to 2.5 GHz	$d = 1.2 \sqrt{p}$ 80 MHz to 800 MHz $d = 2.3 \sqrt{p}$ 800 MHz to 2.5 GHz where $p$ is the maximum output power rating of the transmitter in watts (W) according to the transmitter manufacturer and $d$ is the recommended separation distance in metres (m). Field strengths from fixed RF transmitters, as determined by an electromagnetic site survey, <sup>a</sup> should be range. <sup>b</sup> Interference may occur in the vicinity of equipment marked with the following symbol: 
NOTE 1: At 80 MHz and 800 MHz, the higher frequency range applies.			
NOTE 2: These guidelines may not apply in all situations. Electromagnetic propagation is affected by absorption and reflection from structures, objects and people.			
<sup>a</sup> Field strengths from fixed transmitters, such as base stations for radio (cellular/cordless) telephones and land mobile radios, amateur radio, AM and FM radio broadcast and TV broadcast cannot be predicted theoretically with accuracy. To assess the electromagnetic environment due to fixed RF transmitters, an electromagnetic site survey should be considered. If the measured field strength in the location in which the System is used exceeds the applicable RF compliance level above, the System should be observed to verify normal operation. If abnormal performance is observed, additional measures may be necessary, such as relocating the System.			
<sup>b</sup> Over the frequency range 150 kHz to 80 MHz, field strengths should be less than 10 V/m.			

### Recommended separation distances between portable and mobile RF communications equipment and System

The System is intended for use in an electromagnetic environment in which radiated RF disturbances are controlled. The customer or the user of the System can help prevent electromagnetic interference by maintaining a minimum distance between portable and mobile RF communications equipment (transmitters) and the System as recommended below, according to the maximum output power of the communications equipment.

Rated maximum output power of transmitter <i>W</i>	Separation distance according to frequency of transmitter		
	150 kHz to 80 MHz $d = 1.17 \sqrt{p}$	80 MHz to 800 MHz $d = 0.35 \sqrt{p}$	800 MHz to 2.5 GHz $d = 0.7 \sqrt{p}$
0.01	0.12	0.04	0.07
0.1	0.37	0.11	0.22
1	1.17	0.35	0.7
10	3.69	1.11	2.21
100	11.67	3.5	7

For transmitters rated at a maximum output power not listed above, the recommended separation distance *d* in metres (m) can be estimated using the equation applicable to the frequency of the transmitter, where *p* is the maximum output power rating of the transmitter in watts (W) according to the transmitter manufacturer.

NOTE 1: At 80 MHz and 800 MHz, the separation distance for the higher frequency range applies.

NOTE 2: These guidelines may not apply in all situations. Electromagnetic propagation is affected by absorption as reflection from structures, objects and people.

# Safety

## Electromagnetic Compatibility (EMC)

---

## 3 Theory of Operation

### 3.1 System Description

#### 3.1.1 General

The System consists of a system cabinet and a Ceiling suspended unit (with an X-ray tube and a collimator).

The System can be integrated with the following components:

- a Wallstand with an Image receptor
- a Table with an Image receptor
- a Wallstand and a Table with an Image receptor.

### 3.2 Safety

The Z-movement in the Ceiling suspended unit is strictly motorized and has a suspended mass of approximately 50 kg, depending on tube/collimator configuration. These two factors together generates a potential risk of injury on patients and operators, as well as a potential risk of damaging the System and/or its environment.

The System design minimizes this risk with a number of measures. The strongest of these measures is that the System is hardware supervised which removes the risk of unauthorized/uncontrolled movements. This hardware supervision is realized via a hardware circuit that must be closed in order to allow downward movement below a specified height.

All movements, including the Z-movement, are considered to be safe above a certain height and as long as movement is performed outside the patient area. This later statement allows automatic movement below the safety height in some cases, such as tracking against a Wallstand. Although the ceiling height may differ between 2500 and 3000 mm, the height is calculated to give a safety zone above the table top of minimum 300 mm.

Additional safety measures, in form of electrical switches on the Alpha movement, is included in the System, to secure that the System is in position for enabling tracking below the safety height. The System allows tracking below the safety height, if Alpha is positioned outside the range of +45° to -45°, although it requires an activation of the tracking function toward the Wallstand.

The activation of an automatic movement, i.e. a tracking movement, is performed by activating control buttons with a double switch feature. One switch is connected in series with the emergency stop circuit and the other switch is for enabling the tracking function. The switch connected to the emergency stop circuit is used as a safety measure (DMG, Dead Man Grip) with a delayed activation function. The delay is necessary in order to maintain a controlled retardation of the movement when the control button is released. The time frame for the delay is set to < 1 sec. giving a maximum movement of 150 mm on release of the control button. Note that this switch shall be used as a measure in case of a single fault in the function switch and not as a "quick-stop" function.

Above all internal safety measures, the System includes a number of emergency stops that are connected in the same circuit (see Electrical design, Emergency stop circuit).



### 3.3 Electrical Design

#### 3.3.1 General

##### 3.3.1.1 System Power Supply

The entire System, except for the Image system PC, is powered from the System power supply, placed in the cabinet. The System is designed for the following power inputs:

- 480V 3 ~
- 400V 3 ~
- 400V 3N ~

The System power supply design allows the main part of the System to be powered when the generator ON button is pressed. Consequently it is also switched off when the generator OFF button is pressed. The power to the image system, i.e. the DR sensors, is however always powered

##### 3.3.1.2 Interface and System Logic

The internal System interface has a gathered connection point in the System cabinet. Most of the internal interfaces are collected into one interface board.

The interface toward the image system is handled through a separate board. This board acts as a master in the System and communicates with the image system via Ethernet bus, and with the X-ray system via CAN bus.

##### 3.3.1.3 Exposure Control

The generator has a set of input and outputs, used to validate the conditions for exposure.

These I/Os are validated in different states of the exposure sequence. The behaviour of the System, i.e. the exposure control sequence, is set during installation/production. The System supports the following control signals:

- *Door interlock (input)*

The *Door interlock* input is designed to inhibit exposure and terminate an on-going exposure. This signal is normally used as signal to determine if the door to the examination room is closed. The exposure is inhibited if the circuit is open.

- *EM-Interlock (input)*

The *EM-interlock* input is designed to inhibit a new exposure if the emergency stop circuit is open, i.e. an emergency stop has been activated. An activation of the emergency stop during exposure, does not terminate the exposure but requires that the emergency stop circuit is closed before enabling a new exposure.

- *System Interlock*

The System Interlock signals (Table, Wallstand) are used to inhibit exposure if the Ceiling suspended unit is not in position.

- *X-ray light (output)*

The *X-ray light* output is designed to be used for exposure indication. The output is activated during exposure.

### 3.3.1.4 Emergency Stop Circuit

The emergency stop circuit is an independent circuit which means that by activating an emergency stop, the power to the motors cuts unconditionally and inhibits exposure.

By opening the emergency stop circuit, the power to the motor is switched off and the exposure control circuit is opened, which will inhibit exposure. The logic power to the System control boards is however independent of the emergency stop circuit and is therefore always live. Note that activation of the emergency stop does not stop an on going exposure, just inhibits a new exposure.

### 3.3.2 Electrical Design, Ceiling Suspended Unit

The electronics of the column, consist of a motor (AC) with a frequency converter, motor brake, electrical end stops, safety switches for detection of chain failure and position sensor (absolute encoder).

The motor is powered by the frequency converter which is controlled from the Z/Master control board. The control board also controls the motor brake (electric). The brake is released during movement and engaged at stand still. The brake is also activated by the emergency stop, securing that the column is brought to a complete stop.

The positioning of the column is supervised using an absolute encoder and electrical end stop switches. The encoder is connected to the Z/Master board which, as mentioned above, is controlling the motor and the motor brake. The end stop switches are wired directly to the control signals of the frequency converter and when activated they are inhibiting a movement to be initiated. The design of this circuit allows movement in the opposite direction, e.g. if the high end stop is activated, only a downward movement is possible.

The motor drives the column with the use of two parallel chains to secure the suspension from a single fault (one broken chain). A broken chain is detected via electrical switches that are connected to the emergency stop circuit. On detection, the emergency stop circuit is opened, inhibiting movement until the chain is replaced.

#### 3.3.2.1 The Electrical Brakes for the X and Y Movements

The electrical brakes for the X and Y movements are controlled via relays on the CIB-board (placed in the Ceiling wagon). The Relays are in their turn controlled by the Z/Master board. The Z/Master board communicates with the display board that supervises the handle bar control buttons (release X, release X/Y, release Y). The brakes are powered with 24V which means that the brakes can always be released as long as the System has logic power (emergency stop circuit does not inhibit the brake release function).

The X and Y movement can also be supplied with electrical index switches (option). The function of the index switches is to inhibit exposure if the Ceiling suspended unit is not placed at the specified position.

#### ***Alpha, Beta***

The electrical brakes for the Alpha and Beta movement are controlled via relays on the SBB-board (placed behind the X-ray tube). The Relays are in turn controlled by the display board that supervises the handle bar control buttons. The brakes are powered with 24V which means that the brakes can always be released as long as the System has logic power (emergency stop circuit does not inhibit the brake release function).

The alpha rotation also includes a switch that is used for enabling and disabling tracking below the System safety height limit. The switch needs to be activated in order to enable tracking against a Wallstand (Alpha angle  $\geq 45^\circ$ ).

# Theory of Operation

## Electrical Design

---

### 3.3.3 Electrical Design Table 0181

The Table is powered from the system cabinet. The Table has its own power supply, generating the internal 24 V power.

The Table control board "TCB" is the main hub in the system, all internal electrical components connects to the board.

The only motorized movement is the vertical movement (Z). The vertical movement is controlled via a kick list (foot pedal) or a hand control. The controls have separate controls for each direction (up/down).

#### 3.3.3.1 Vertical Lift

The electronic parts of the lift consists of a frequency inverter, motor (AC), electrical end stops, low speed switches and a safety switch.

The movement starts when the frequency inverter receives a signal from the foot switch/handlebar which starts the motor. In case of hardware failure the safety switch will stop the movement downward and the movement upward will be stopped by a mechanical end stop.

#### 3.3.3.2 Table Top Brakes

When activating the brake release control, a relay on the TCB board activates the brake magnets. The magnets affect the friction coated metal plates and the unit is released.

### 3.3.4 Electrical Design Two column table (option)

The table has its own power supply, generating the internal 36 V power and the 24 V logic power.

The main power (230 V) to the table as well as the detector holder control signals are routed via the system cabinet. The table mains is controlled in the same manor as the OTC, e.g. the On/Off- function is controlled via the generator On/Off- function.

The table control board controls all functions of the table besides the detector release function and the emergency stops which are controlled by the user directly. All signals, except the emergency stop circuit, pass through the control board where they are validated. If the requested operation is cleared by the control board, the operation is carried out.

The control board controls a trig relay which is connected to a relay that is used for switching on and off the power to the drivers (36 V). The trig relay will react in case of signal loss from the control board, i.e. if the control board is malfunctioning.

#### *Note!*

---

*The emergency stop does not affect the logic power (24 V), hence the control board will be powered at all times.*

---

The only motorized movement is the vertical movement (Z).

The vertical movement is controlled via a hand control (standard control unit) and/or a foot control unit. The controls has separate controls for each direction (up/down). Each control has two switches that are supervised by the table control board. The control board controls to the two drive units (that in turn controls the power to the motors. The movement is continuously controlled by the master node via the position sensors that are placed within each column.

#### 3.3.4.1 Electronic parts

The components included in the table are mainly dependent on the configuration of the columns (motorized vertical movement, motorized detector movement or fixed table height).

The main components (including motorized vertical movement) are:

- A power supply
- A control board (CB)
- Two drivers
- Controls (foot control for the vertical movement and the table top brakes and a switch for controlling the brake for the detector holder).
- A tilt sensor
- A power relay (36 V)
- A trig relay (time relay), used as watchdog, timer triggered.
- Emergency stops (2 pcs.)
- Electrically controlled brakes for the table top and the detector holder.
- Sensor for the table height (potentiometer).
- Electrical options available for two column table (including motorized vertical movement) are:
  - An output (relay) that will be activated when the table top brakes are released.
  - Table top crash guard (stops the vertical movement if a collision is detected).
  - External emergency stop input
  - Controls (table top brakes only)

### 3.3.4.2 Columns

The electronics of the columns consists of a motor (DC), motor brake, electrical end stops and position sensor (potentiometer).

The movement is started when the motor receives power from the driver and the control board releases the motor brake. The sensor feeds the position back to the control board. In one of the two columns an additional sensor is added. The extra sensor is used as a position input to the system and is isolated from table internal electronics. In case of hardware failure or an incorrect calibration the movement is stopped when one of the electrical end stops is activated. The end stops activates a hardware input on the driver which automatically inhibits the movement in the current direction (movement stopped).

### 3.3.4.3 Brakes

The table top brakes are controlled via an output of the control board. The detector brake is connected via a relay on the 24 V logic power. This means that the brakes can always be released as long as the table is powered (24 V logic power). On activation of a brake release control, the control board activates a relay that in its turn activates (power is activated) the brake magnets. The magnets affect the friction-coated metal plates and the unit is released.

The brakes include a solenoid and two friction-coated metal plates. The solenoid releases the brake, two metal plates away from the table top U-bar. When the solenoid has pulled the two metal plates, a micro-switch deactivates the larger coil of the solenoid which reduces the current used. When the brake is deactivated (engaged), the power to the smaller coil is cut and a spring pulls a gear mechanism, which pushes the metal plates toward the U-bar. This means that the brake is normally engaged and is not dependent on power to stay engaged.

The detector brake consists of a simple magnet that is activated when the powered (24 V). When powered the magnet becomes magnetized and reacts against a metal plate inserted in the table frame.

### 3.3.4.4 Table top output (option)

The system is able to deliver an output that is activated when the table top brakes are released. The CB activates a relay when the brake output is activated. The output is intended to be used for activating a collimator lamp but may be used for other purposes defined by the user.

# Theory of Operation

## Electrical Design

---

### 3.3.4.5 Tilt sensor

A sensor that detects the angle (tilt angle) of the table is used for protecting the system.

The tilt sensor delivers an analogue signal to the control board. The control board deciphers the signal and if the tilt angle is outside the specified range the control board activates an output that in turn activates a relay. The activation of the relay affects the hardware inputs on the drivers and the movement in the current direction is inhibited (movement stopped). To secure a quick and effective stop the motors for the vertical movement is short circuit.

### 3.3.4.6 Table top crash guard (option)

The table top crash guard shall only be primarily used as a safety precaution for the system but will of course limit the risk of personal injury as well, although the function does not guarantee the accuracy needed for usage as a patient protection.

To be able to detect a collision, four sensors are placed between the table frame and the columns. The sensor produces an analogue signal that goes to an input on the guard board. The guard board amplifies the signal and check if the value is within the specified range. If the signal is not within range the guard board activates an output which in turn activates a relay. The activation of the relay affects the hardware inputs on the drivers and the movement in the current direction is inhibited (movement stopped).

The guard function is only activated during movement to prevent a temperature deviation and other possible effects that the placing of the guard board might inflict. The activation of the function is made by the control board and is communicated via a CAN-bus. The CAN-bus goes through a second board (BCM) to secure the termination of the bus.

### 3.3.4.7 Controls

The system has a number of control units allowing the user to control the movements and the functions of the system. There are three different types of foot controls and two types of hand controls.

Each control has two separate switches for the functions, operating safety critical movements. The separate switches shall be used for validation of the functionality of the control (validation performed by software).

The hand control is designed to support the functions with two separate switches (DMG). The control is structured by laminate, including domes, switch layer and a silk-screen layer, connected to a small PCB placed inside the aluminium profile.

The advanced hand control includes functions for controlling functions of the OTC. The signals used for controlling table functions are connected to CB-module used for supervising the table. This means that the signal wires, coming from the hand control are split up inside the table and connected to two separate modules.

### 3.3.4.8 Detector holder, table

The manoeuvre control, controls the detector carriage brake.

When the control is activated, the carriage is free to move and when released, the brake is activated holding the carriage in position. The brake is normally activated, at power loss the brake will release.

The detector carriage is designed to accommodate detectors and detector holders. The electrical design of the detector holder is made in the same manner, e.g. standard electronics are used for all detector/detector holder options and additional electronics are added to suit each individual option.

When using a fixed detector in the table, a power box for the detector is mounted underneath the table.

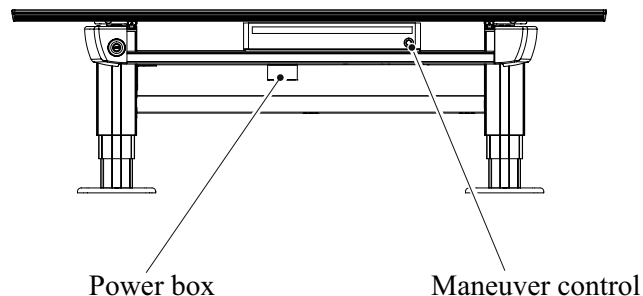

*Fig. 3-1 Location of power box*

### **3.3.4.9 System nodes, motorized, vertical movement**

#### **General**

The system is divided into two logical subgroups. Each group contains several nodes, all with different responsibility and tasks. The difference between the two sub groups, is their emphasis of functionality.

The main priority of the control nodes subgroup is to act as a link to the surrounding world and to feed the system (other nodes) with input. The input of the control nodes are used to control and manage the nodes of the motor nodes subgroup. All data is passed through the master node, which main task is to supervise and control the system.

The task of the nodes in the motor nodes subgroup is to, based on the commands from the master node, move the system in different directions. Each motor node controls a specific axis (direction of movement).

# Theory of Operation

## Electrical Design

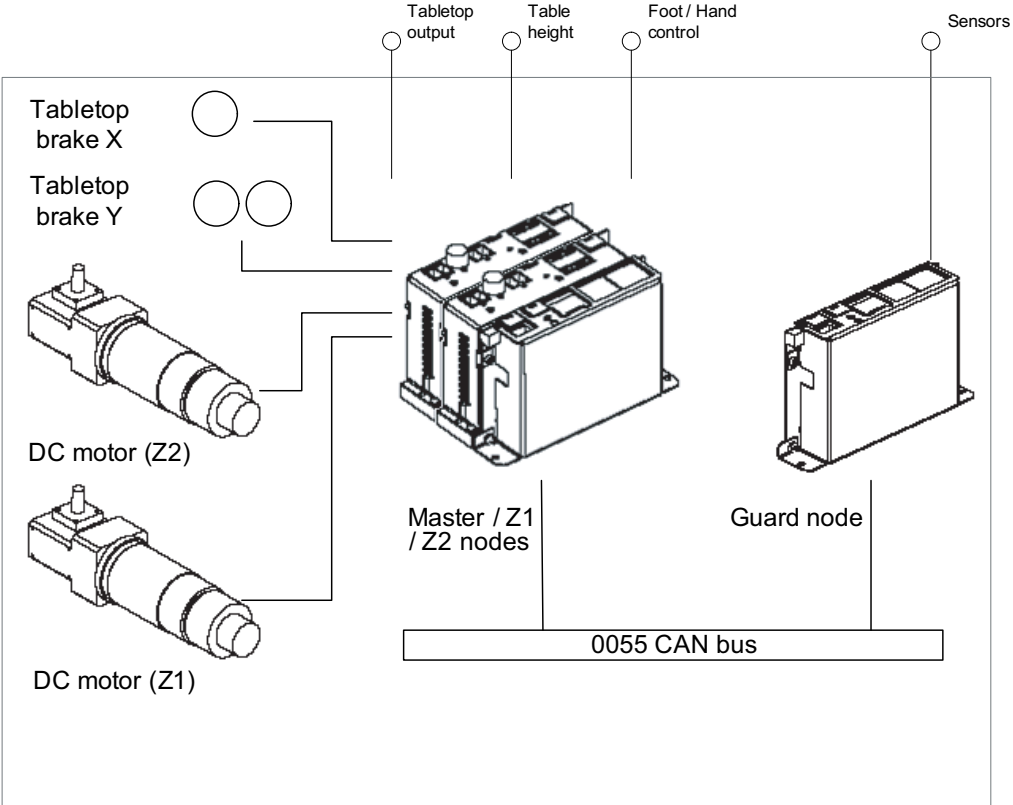

Fig. 3-2 System nodes



### 3.4 Mechanical Design

The System is mechanically designed to be ergonomic and at the same time robust.

#### 3.4.1 OTC, Mechanical Design

The OTC is designed to be extremely light and maneuverable. The OTC has five individual movable axis; X, Y, Z, Alpha and Beta (see Picture 1). All axis of the OTC are manually maneuverable except for the Z-movement (up/down).

All movements have mechanical end stops. The Alpha and Beta movements also have mechanical indexes to indicate fixed positions (-90°, 0° and 90°).

The Z-movement is strictly motorized and controlled via buttons on the handlebar. All brakes are electrical and controlled by a simple press of a button. All control buttons are placed on the handlebar, placed at the front of the X-ray tube. The control buttons for the collimator are placed adjacent to the handlebar, giving the operator a single access point. For a more detailed design description of the OTC.

#### 3.4.2 0181 Table, Mechanical Design

The Table is a high performance product, designed to cover most kinds of examinations and patient types. Maximum load is 295 kg.

The floating table top is manually moved, whereas the Table Z-movement is motorized. The table top brakes are electrical, allowing the operator to control them with a simple press of a button.

##### 3.4.2.1 Table Top Crash Guard

The Table top crash guard shall only be primarily used as a safety precaution for the System. It will as well limit the risk of personal injury, although the crash guard does not guarantee patient protection.

To be able to detect a collision, four micro switches are placed between the Table and the table top. If the Table crashes into an object, the micro switches will stop the moment in the ongoing direction, but it will allow the movement in the opposite direction. When the object is removed, the Table can be moved in both directions again.

#### 3.4.3 Two column table (option)

##### 3.4.3.1 Power supply box

The power supply box contains electronics of the table and for external products such as power supply for detectors etc. the design allows electrical plates to be pre-assembled and attached as a whole into the power supply box.

All cables, used for installing the table is passed through a conduit, running from the head end foot plate to the power supply box.

##### 3.4.3.2 Column

For the motorized solution the columns will consist of three segments. The mechanics and the electrical components are placed within each column. The concept of the mechanics includes a movable ball screw, ball nut, a safety nut and a mechanical brake. A motor rotates a cylindrical bracket that holds the ball nut. When the ball nut is rotated the ball screw is moved upward or downward dependent on the direction the ball nut is rotated. The brake operate on friction which means that an increase of load causes the brake force to increase. There is also an electrical brake at the motor axle.

### 3.4.3.3 Detector holder

The detector holder is manually movable along the table top in the X-direction. The detector holder moves between two aluminium profiles that are attached to the table frame. The attachment of the detectors is adjustable to decrease the distance between the table top and the detector holder. The detector holder is normally locked via a magnet, locking against a steel plate inserted in the aluminium profile. The brake is controlled via a switch placed on a handlebar directly beside the detector holder. It can be supplemented with up to three mechanical indexes that are used for an easy positioning of the unit.

### 3.4.3.4 Controls

There are three different types of foot controls and two types of hand controls available as standard or as options. Each control has two separate switches for the functions operating safety critical movements. The separate switches shall be used for validation of the functionality of the control (validation performed by software).

### 3.4.4 Wall stand

The up and down movement of the Wallstand can be both manually and motorized controlled. The movement is counter-weighted, allowing a manual movement with a very small applied force. For motorized movement the motor is connected to the shaft with a clutch, this is also to reduce the force for manual movement.

The tilting function is balanced in order to reduce the applied force. With a tilting function the imaging unit can be set in any angle within a range of 90 to minus 20 degrees. The imaging unit is locked in position using a mechanical brake. To help the user to find the most frequently used positions, three mechanical indexes (90°, 0° and -20°) are implemented.

### 3.5 Functional Description

#### 3.5.1 General

The functional design of the System is based on the fundamental requirements and values of the System. Functions of the System are intuitive, i.e. the System is intended to be easy to use without any extensive training and understanding of the functions of this particular System.

#### 3.5.2 Description

The System is operated from interfaces inside the examination room and from the operating room. The exposure controls are placed at the display, and in the operating room whereas the positioning controls are placed in the examination room (lab). The basic idea is that the functions shall be operated from the position where they are needed, which will enhance the workflow and increase the efficiency.

##### 3.5.2.1 Positioning Function Controls

The positioning of the System is performed inside the examination room, i.e. the controls for the positioning functions are also placed inside the examination room. All position controls use a "continuous activation technique" which basically means that the operator must press and hold the key to activate the function. On release, the function will be deactivated.

# Theory of Operation

## Functional Description

### 3.5.3 Overhead tube crane

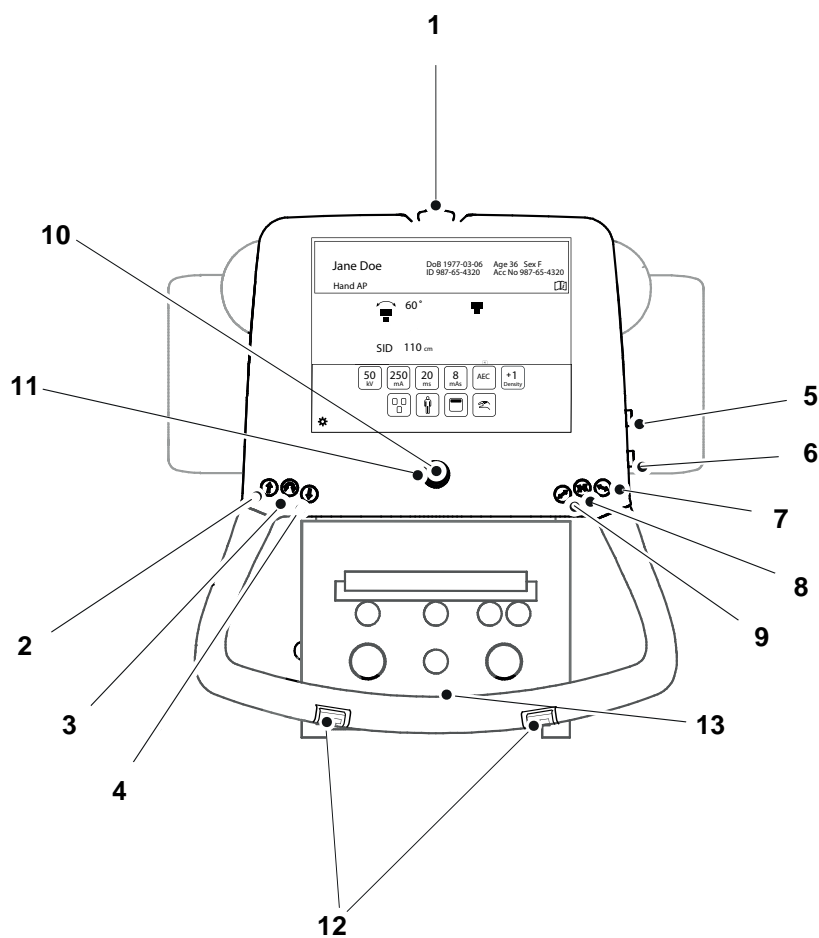

1. Emergency brake
2. Z movement up
3. Alpha Beta rotation
4. Z movement down
5. Z movement up
6. Z movement down
7. Unlock X brake
8. Unlock X and Y brake
9. Unlock Y brake
10. Indication light, tracking
11. Synchronization button, tracking
12. Z-movement, up/down
13. Handle frame (option): X-/Y-brake release button

# Theory of Operation

## Functional Description

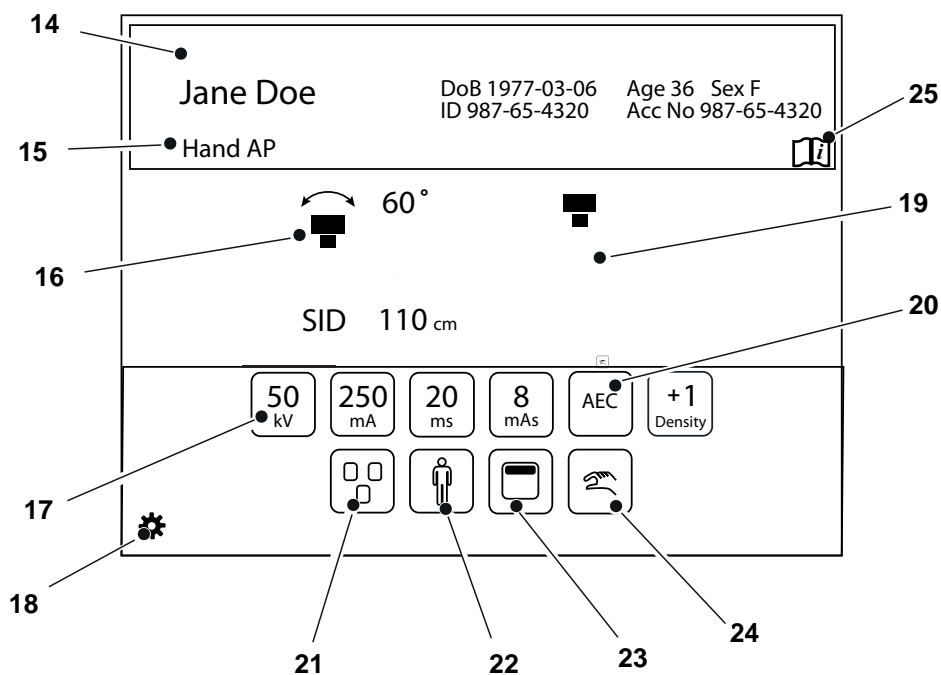

14. Patient information
15. Active protocol
16. Position information
17. Adjustment of generator parameters: kV, mA, ms, mAs, Density
18. Settings and service menu
19. Active mode, see chapter
20. Selection of Technique mode
21. Selection of active AEC field (AEC mode only)
22. Patient size
23. Collimator centering
24. Activation of wallstand or Table tracking
25. Hospital manual

# Theory of Operation

## Functional Description

### 3.5.4 Automatic Collimator Version (option)

Below is a description of the controls on the Siemens AL02 collimator.

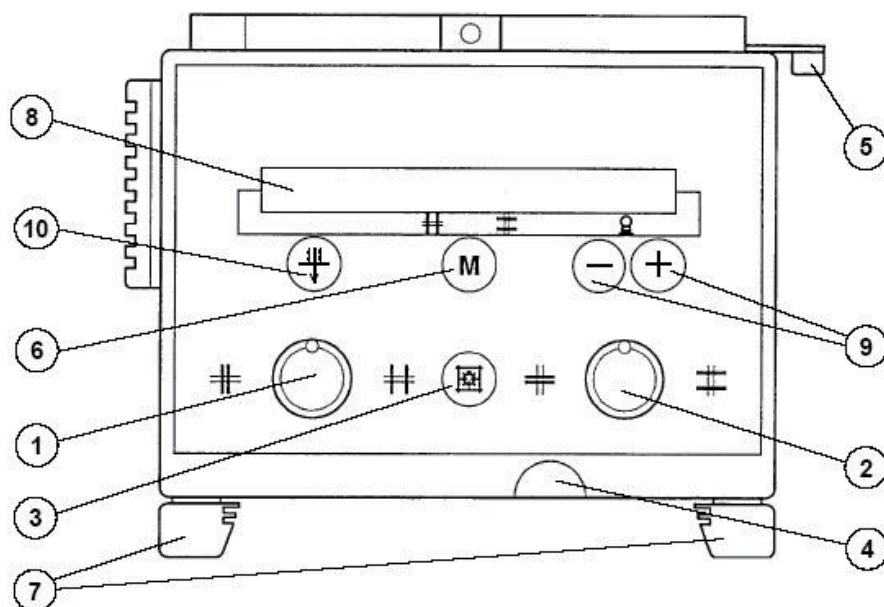

Fig. 3-3 Siemens AL02 Collimator Controls

1. Adjusting knob for formatting height collimation (Turning to the left closes the collimator, turning to the right opens the collimator).
2. Adjusting knob for formatting width collimation (Turning to the left closes the collimator, turning to the right opens the collimator).
3. Button turns the X-ray field illumination and linear light localizing on/off. Cut-out is also performed automatically via a time switch.
4. Measuring tape grip for SID measurement - Take reading at bottom edge of multi-leaf collimator. - The measuring tape has both a cm— and an inch-graduation.
5. Detent lever for  $\pm 45^\circ$  rotation of the collimator around the central beam axis. - The collimator only stops in the  $0^\circ$  position.
6. Button for changing between automatic and manual mode. A long activation (approximately 2 seconds) of the M button will set the light field to maximum size.
7. Two accessory rails.
8. Function display will indicate manual or automatic mode of the collimator.
9. Buttons for manual changing of SID. The new SID value will then be used for calculating the field size instead of the *collimator default value*, steps: 100, 115, 150, 180, 200.
10. Button for selecting collimator filtration.

### 3.5.4.1 SID

#### **Changing SID**

The SID used for calculating the size of the light field can be changed manually with button no. 9 on the collimator.

The new SID value will then be used for calculating the field size instead of the SID *Collimator default value*.

#### **Pre-programmed SID values**

If the SID values for each APR are pre-programmed at the Canon NE user interface, this will override the *Collimator default value*.

# Theory of Operation

## Functional Description

---

### 3.5.5 Functional Description, Table

The control of the Table is placed on the lower part of the vertical lift as a kick box or on the floor as a foot control, there is an optional hand control. The controls are used for enabling and disabling of functions of the Table. These functions are described below.

#### 3.5.5.1 Movements

The Table can be moved in Z-direction for up and down movements and in X- and Y-direction for longitudinal and lateral movements. See figure below for different controllers.

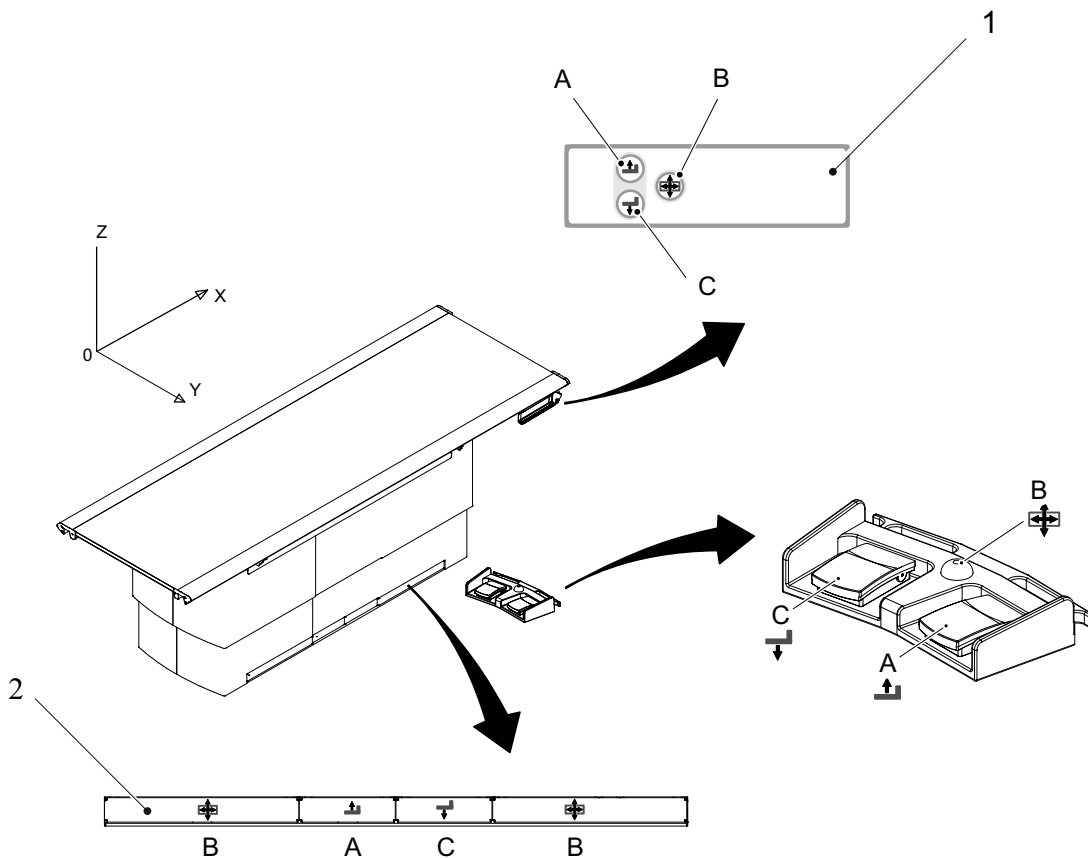

Fig. 3-4 Table controls

1. Maneuver hand control (optional)
2. Kick box control



# Theory of Operation

## Functional Description

---

Table 3-1

Pos.	Direction	Movement	Activation
A	Z up	motorized	Press and hold the button to activate the movement.
C	Z down		Release the button to stop the movement.
B	X and Y lateral and longitudinal	Manual	Press and hold the button to release the break and to be able to move the Table top.  Release the button to activate the brake and the Table top will be locked.

---

**CAUTION!**

- **When moving the Table with the patient or devices nearby, be careful so the Table does not come in contact with the patient and devices.**
  - **When lowering the Table, be careful so the patient does not carelessly come in contact with the Table.**
  - **When moving the Table or the Table top, be careful not to get your arms and fingers caught in the device.**
  - **When moving the Table by foot control or maneuver handle, be careful not to get your arms and fingers caught between the Table and surrounding objects.**
- 

**CAUTION!**

**When turning on power, do not operate foot control, maneuver handle or kick box control. It may lock.**

---

# Theory of Operation

## Functional Description

---

### *Moving the Table Top*

To manually move the Table top, release the brakes and use the hand grip rails located at the long sides of the Table top.

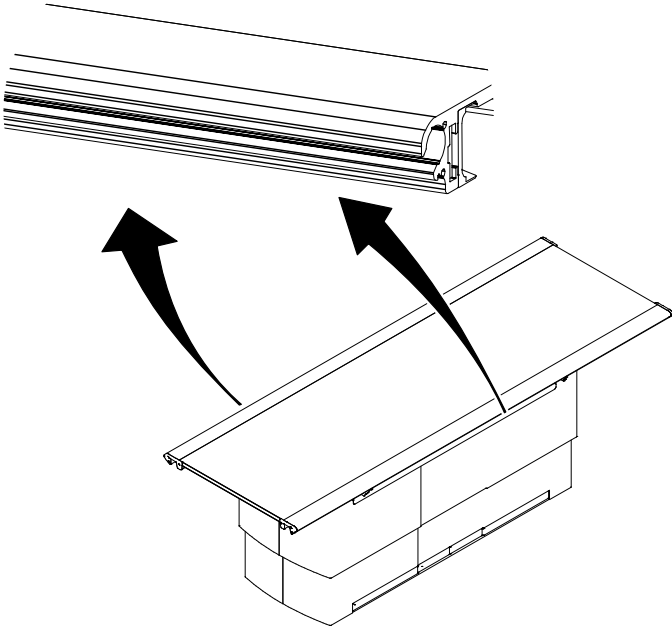

*Fig. 3-5 Manually movement of Table top*

### 3.5.5.2 Grid, closed table

#### Remove grid

1. Pull out the grid.

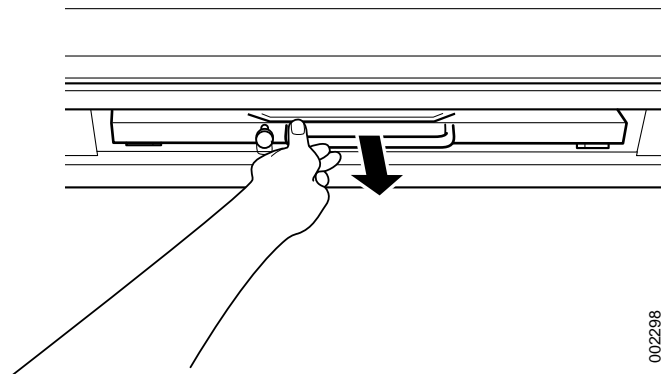

Fig. 3-6

#### Insert grid



#### **WARNING!**

**Failure to insert the grid in the correct orientation, with the tube side facing towards the X-ray source, can result in unsuccessful patient imaging.**

**Additional corrective patient imaging and additional ionising radiation exposure for the patient may be needed.**

**Ensure the grid is inserted in the correct way.**

#### **CAUTION!**

**Use the grid that is appropriate for exposure conditions (focus distance, etc.)**

Hold the grid in both hands holding the metal on the sides of the grid, and insert the grid along the grid holder rail on the top of the detector tray.

#### **CAUTION!**

**Properly insert the grid along with the rail. The device may be damaged if not mounted properly.**

#### **Note!**

**When mounting the grid, after confirming that right side is up, check to make sure that it is mounted correctly with the top surface towards you.**

**The top surface is the one with the sticker affixed to the metal handle of the grid surface.**

1. Insert the grid with the tube side facing upwards, towards the X-ray source. The tube side of the grid has the specification label and the grid centre line identification.
2. Push in the grid, until it clicks.

# Theory of Operation

## Functional Description

---

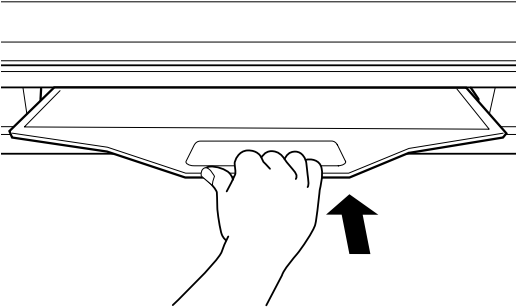

Fig. 3-7

### 3.5.5.3 Two column table (option)

The control of the table is placed at the handlebar installed on the table top and/or on the floor in form of a foot control (option) or a strip tape switch (option).

#### Movements

The control for the brake is placed on the right side of the detector holder. The controls are used for enabling and disabling of functions concerning the table. These functions are:

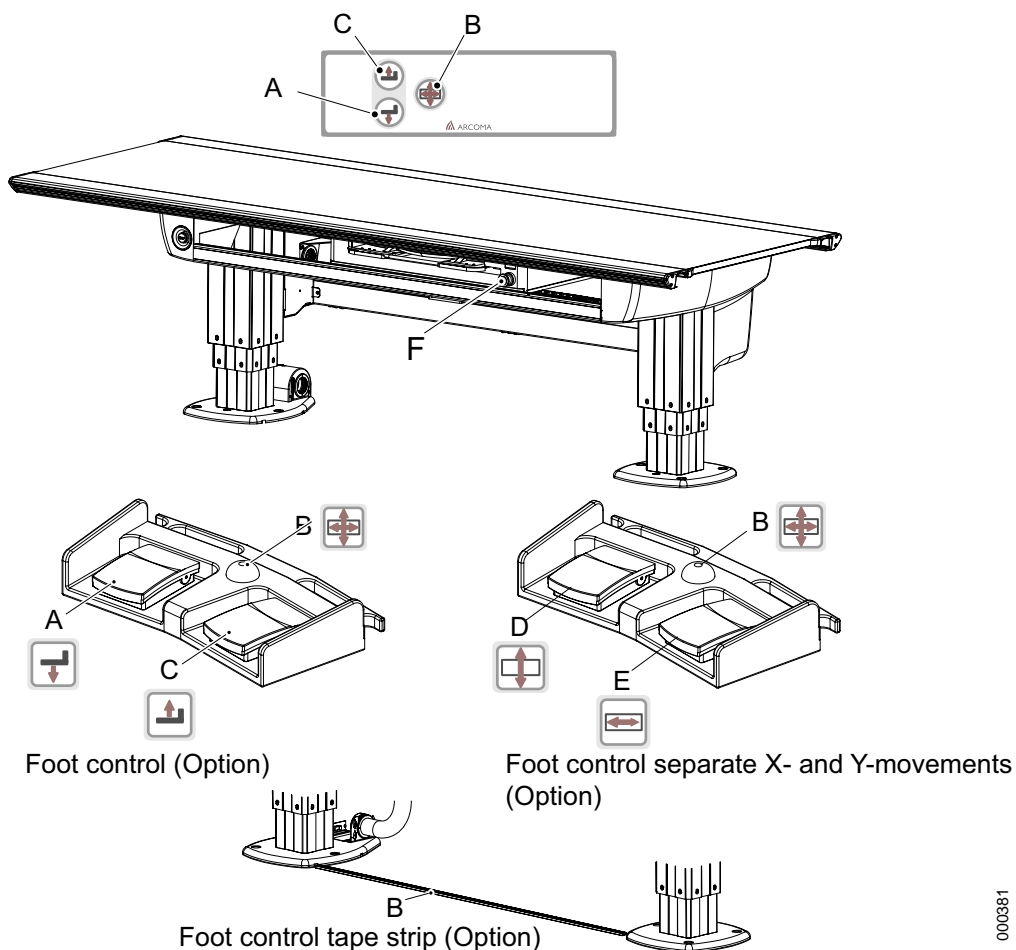

Fig. 3-8

- |   |  |
|---|--|
| A Move down   | E Release/engage table top brake (X-direction) |
| B Release/engage brakes of the table top (X- and Y-direction) | F Release/engage detector holder brake         |
| C Move Up   |  |
| D Release/engage table top brake (Y-direction)                |  |

000381

# Theory of Operation

## Functional Description

---

The table top release key (B) automatically lights the collimator lamp on activation. The collimator lamp is automatically switched off after a pre-defined time when the table top release key has been deactivated (released).

**Note!**

---

*The collimator light is not switched on during vertical movement. The light is only for positioning of the patient and or the radiation beam.*

---

The Up/Down function keys (A, C), also generally named movement keys, are also used for enabling movement of the overhead tube crane (Z-direction). This function is used when tracking is activated.

The user must keep the function key activated during the movement. When the function key is released the movement stops.

On activation of the Up/Down function keys an automatic movement of the OTC is allowed. The automatic movement is used for tracking the vertical movement of the detector.

The tracking of the table detector is only valid if the tracking is activated.

**Grid, two column table**

See 3.5.5.2 *Grid, closed table*, Page 65.

### 3.5.6 Automatic Collimator Control, Table (option).

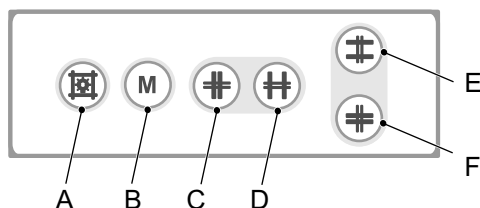

*Fig. 3-9 Table Automatic Collimator Control*

- A. Button turns the X-ray field illumination and linear light localized on/off. Cutout also performed automatically via a time switch.
- B. Button for changing between automatic and manual mode. A long activation (approximately 2 seconds) of the button will set the light field to maximum size.
- C. Button for closing the format height collimation
- D. Button for opening the format height collimation
- E. Button for opening the format width collimation
- F. Button for closing the format width collimation

# Theory of Operation

## Functional Description

---

### 3.5.7 Functional Description Wallstand

#### 3.5.7.1 Manual Wallstand

The Wallstand can be delivered with two different receptor holder wagons:

- Fixed image receptor holder wagon.
- Tiltable image receptor holder wagon.

The control of the Wallstand is placed on the image receptor holder wagon, there is an optional foot control. The controls are used for enabling and disabling functions concerning the Wallstand. These functions are described below.

The Wallstand is always manually moveable in the Z-direction. The movement is counter weighted, allowing a movement with a very limited force applied. The tilting function is also balanced in order to reduce the applied force. With a tilting function the receptor holder can be set in any angle within a range from  $-20^{\circ}$  to  $+90^{\circ}$ . The receptor holder is locked in its position using a mechanical brake. There are mechanical index positions in  $0^{\circ}$  and  $+90^{\circ}$  and a grade scale that displays the angle of the tilt in every 5th degree.

The Wallstand controls are placed on the image receptor holder bracket and at the foot of the column. These functions are:

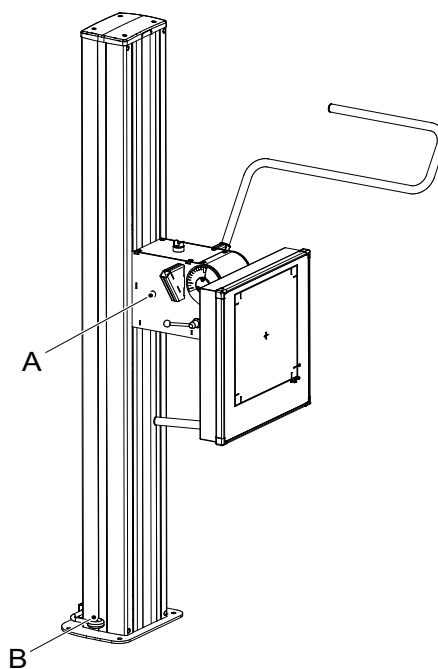

Fig. 3-10 Wallstand Controls

A Tracking function key

B Release/Engage image receptor brake (Z-direction)

If tracking against the Wallstand is selected, the image receptor brake (B) automatically lights the collimator lamp on activation. The collimator lamp is automatically switched off after a pre-defined time when the image receptor brake key has been deactivated (released).

The image receptor brake (B) can externally be used for enabling movement of the OTC (Z-direction). This function is used when tracking is activated. On activation of the image receptor brake an automatic movement of the OTC is allowed. The automatic movement is used for tracking the movement of the image receptor and to synchronize (align) the X-ray tube and the image receptor.



# Theory of Operation

## Functional Description

---

The Wallstand is also supplied with an additional synchronisation key (A). By pressing and holding this key an automatic movement is initialized in order to align the X-ray tube and the image receptor. See also OTC, Tracking function keys.

The tracking of the Wallstand image receptor is only valid if the tracking is activated.

# Theory of Operation

## Functional Description

---

### 3.5.7.2 Manual Z Movement

The Wallstand can be moved manually in Z-direction for movements upward and downward. A button (B) for brake release is placed on the left and right sides of the image receptor holder wagon. An optional button for brake release is placed on the foot control.

Press and hold the button (A or B) to release the brake and push the wagon up or down.

Release the button (A or B) when the image receptor holder is in position and the brake will be activated and locked.



#### **WARNING!**

---

***Hazardous situations when moving the tilted image receptor holder in Z-direction to the floor:***

- ***Image receptor collision with the floor***
  - ***Squeezing hazard for patient***
- 



#### **WARNING!**

---

***Whenever any item is removed from the Wallstand, e.g. image receptor holder, it will become highly unbalanced.***

***Whenever the brake is released it will move upward and can cause injury.***

***Make sure that the operation will be carried out by personnel who are trained in the use of the equipment.***

---

#### **CAUTION!**

---

- ***Before raising or lowering the image receptor holder, be sure to check the position of the patient.***
  - ***When raising or lowering the device with the patient nearby, be careful so the device does not come in contact with other devices or the patient.***
  - ***When raising or lowering the patient support grip, be sure the patient is not hanging down from the grip.***
-

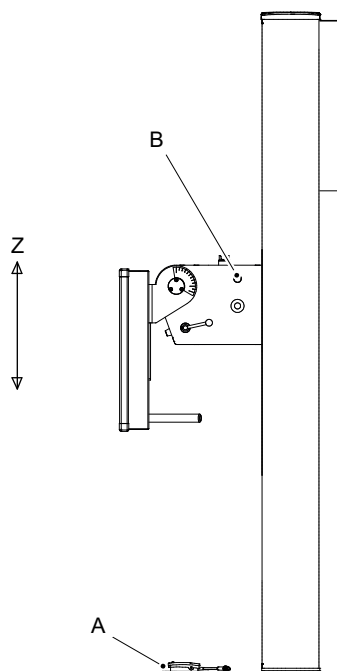

*Fig. 3-11 Manual Z-movement Controls*

# Theory of Operation

## Functional Description

---

### 3.5.7.3 Motorized Z Movement

The controls concerning the motorized wall stand are placed on the imaging unit holder bracket and at the foot of the column.

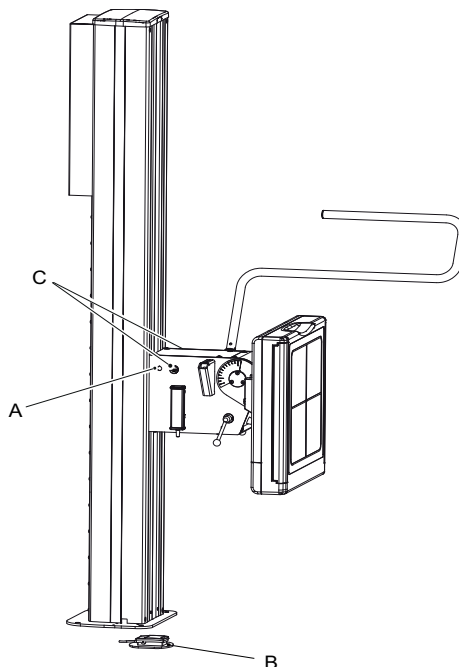

Fig. 3-12 Motorized Z-movement controls

These functions are;

- A. Release/Engage imaging unit brake (Z-direction)
- B. Release/Engage imaging unit brake (Z-direction)
- C. Emergency STOP

The imaging unit brake key (B) automatically lights the collimator lamp on activation, if wall tracking is selected and detector is moved. The collimator is automatically switched off after a pre-defined time when the imaging unit brake key has been deactivated (released).

The imaging unit brake key (B), generally named movement key, is also used for enabling movement of the OTC (Z-direction).

On activation of the imaging unit brake key, an automatic movement of OTC is allowed. The automatic movement is used for tracking the movement of the image receptor and to synchronize (align) the x-ray tube and the imaging unit.

### 3.5.7.4 Detector, detector holder and grid

#### *Tiltable detector holder (option)*

The wallstand has an optional tiltable detector holder wagon. The wagon can make it possible to tilt the detector holder from  $-20^{\circ}$   $+90^{\circ}$ . See index positions in the figure below

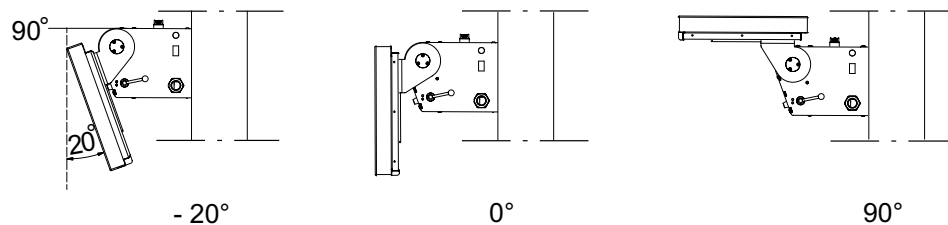

Fig. 3-13 Index positions

#### *Tilt the detector holder*

Turn the handle (1) up to unlock the tiltable detector holder according to picture B in figure below. Push the detector holder up in right position and then turn the handle down to lock the holder, see picture C in the figure below.

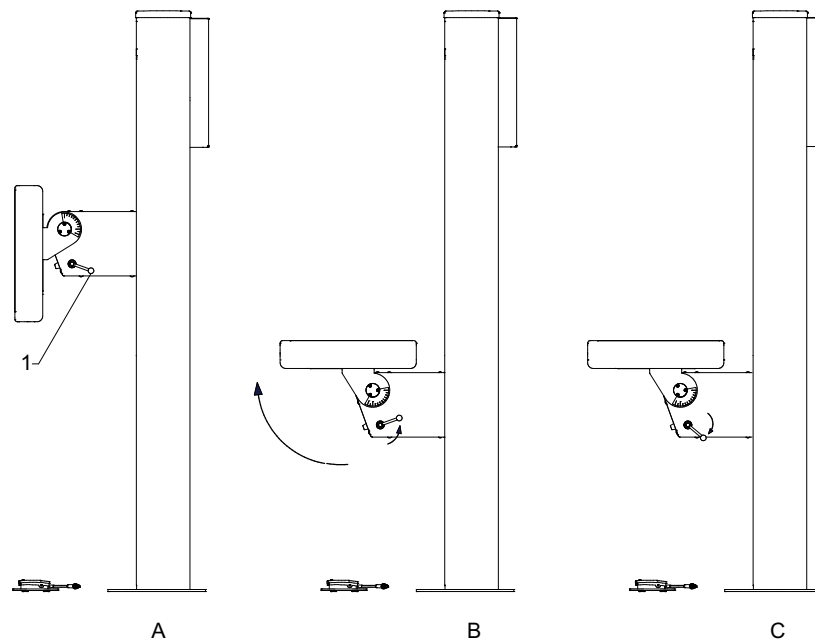

Fig. 3-14 Tilting detector holder

#### *Start position of the handle*

**CAUTION!**

**Squeezing hazards:**

**between the detector holder and other parts or devices when adjusting the angle of the detector holder.**

**for fingers when operating the detector.**

**for arm and fingers when operating the detector holder**

To position the handle (See pos.1 in Fig. 3-14 *Tilting detector holder*, in its start position);

1. Drag the handle out from the wagon

# Theory of Operation

## Functional Description

---

2. Turn the handle to the right position
3. Push the handle back toward the wagon

### 14x17 Detector, wallstand

#### Method to load the 14x17 detector, removable grid

The method of setting the detector to the detector holder is as follows. Following instruction describes the detector operated from the right side.



#### **WARNING!**

- **Before setting or adjusting of detector and other equipment, complete the setting of the counterweights.**
- **Whenever any item is removed from the wall stand, e.g. detector, it will become highly unbalanced, Whenever the brake is released, it will move upward and can cause injury. Make sure that the operation will be carried out by personnel who are trained in the use of the equipment.**
- **Shut down the power when changing of the detector. Confirm that it is not possible to elevate. If the detector holder elevates accidentally while work is being carried out, it may fall against the operator and result in serious injury.**

#### **Note!**

- Depending on left or right operated wall stand, the location of the detector tray and position of button and latches is different.

1. Pull the detector tray toward you until it locks.

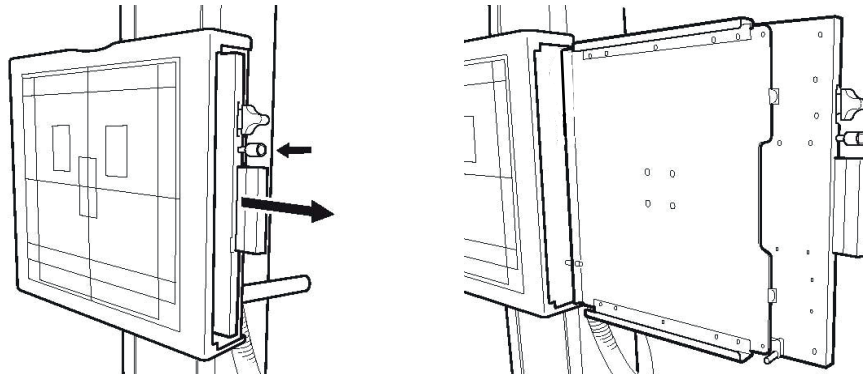

#### **Note!**

- Install the detector with the detector tray pulled into the locked position. When pulling the detector tray, first the button on the side of the tray will recede before snapping back into its original position when it locks.

# Theory of Operation

## Functional Description

---

2. Insert the detector into the detector tray as shown below and set it by pushing it in until it clicks.

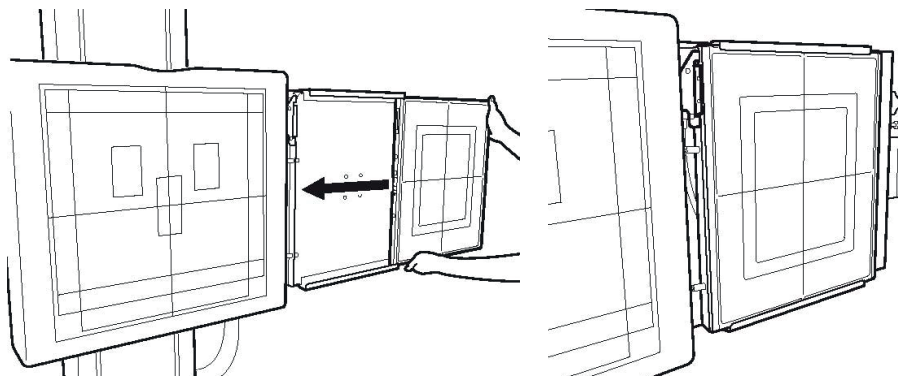

### **CAUTION!**

- **Confirm that the latch is going up firmly, as shown below.**

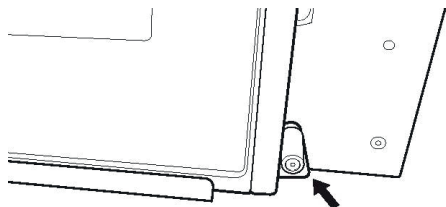

3. While pressing and holding the button of the detector tray, return it back to the inside of the detector holder.

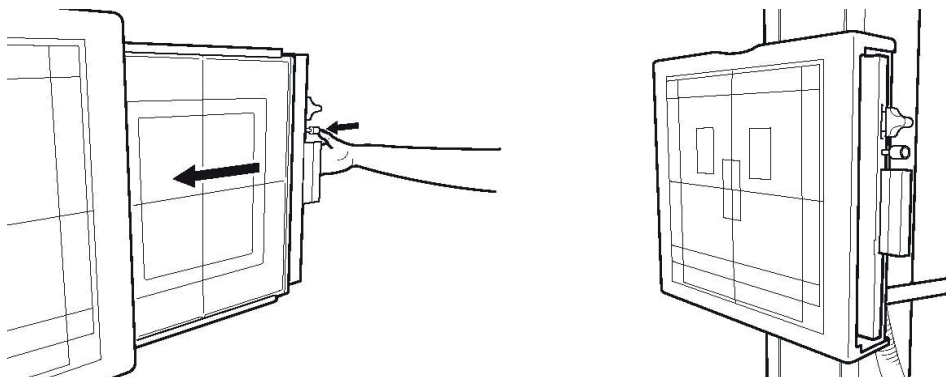



# Theory of Operation

## Functional Description

---

### **Method to rotate the 14x17 detector, removable grid**

The method of rotating the detector in the detector holder, is as follows.

1. To rotate the detector by 90°, in the step 2 of “Method to set the detector”, hold the lower side of the detector and turn it from the below, toward you (2) while pulling the latch upward or downward of the detector tray (1) in the direction of the arrow.

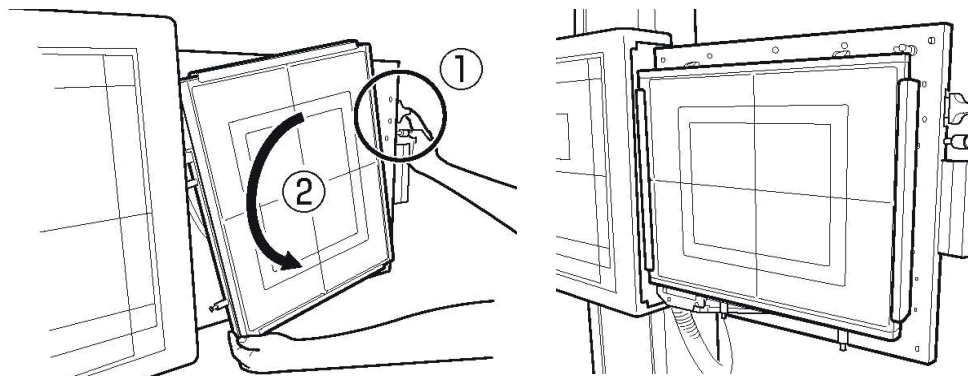

### **Note!**

- To set the detector, pull the latch
    - upward at upper position of the tray.
    - downward at the center of the tray.
  - Depending on left or right operated wallstand, the location of the detector tray and position of button and latches is different.
-

# Theory of Operation

## Functional Description

---

### *Method to remove the 14x17 detector, removable grid*

The method of removing the detector from the detector tray is as follows.

1. To remove the detector, in the step 2 of "Method to set the detector", unlock the connector by pulling the latch of the detector tray in the direction of the arrow.

### *Note!*

- Depending on left or right operated wallstand, the location of the detector tray and position of button and latches is different.
- 

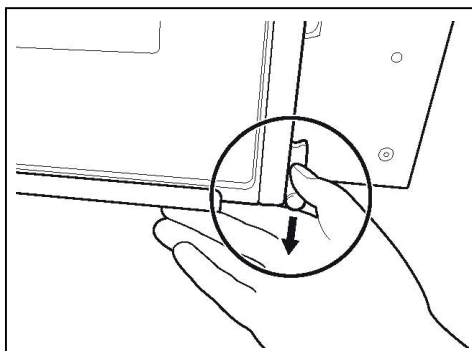

Fig. 3-15

### 17x17 Detector, wallstand

#### Method to load the 17x17 detector



#### **WARNING!**

---

- **Before setting or adjusting the detector and other equipment, complete the setting of the counterweights.**
  - **Whenever any item is removed from the wallstand, e.g. detector, it will become highly unbalanced.**
  - **Whenever the brake is released, it will move upward and can cause injury. Make sure that the operation will be done by personnel who are trained in the use of the equipment.**
  - **Shut down the power when changing the detector. Confirm that the detector holder is not possible to elevate. If the detector holder elevates accidentally while work is being carried out, it may fall against the worker and result in serious injury.**
- 

#### **Note!**

---

- Depending on left- or right-operated wallstand, the location of the detector tray and position of button and latches is different.
- 

The method of setting the detector to the detector holder is as follows;

The following instruction describes the detector operated from the left side.

1. Pull the detector tray toward you. Make sure the detector tray is completely brought out.

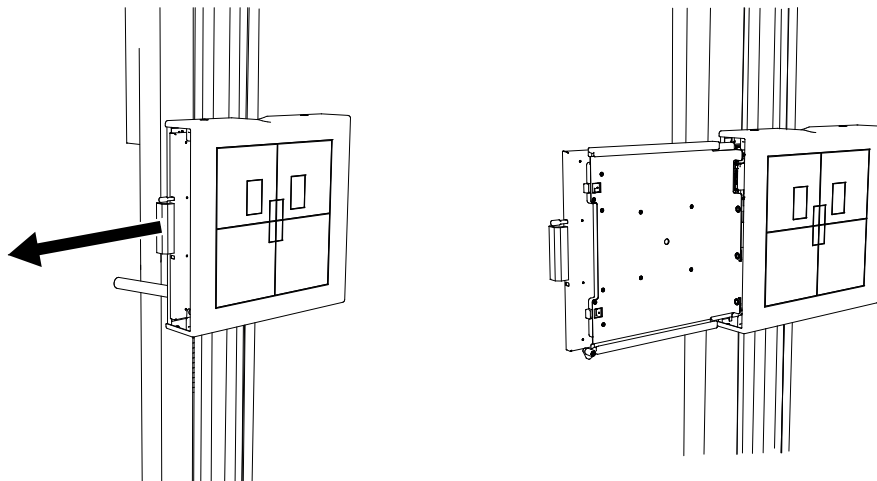

2. Insert the detector into the detector tray as shown below and set it by pushing the detector, holding down the latch.

# Theory of Operation

## Functional Description

---

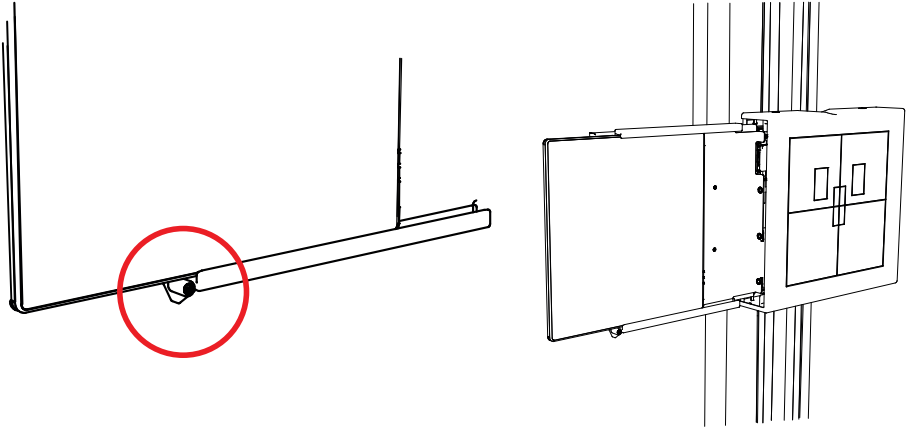

3. While pressing and holding the button of the detector tray, return it back to the inside of the detector holder.

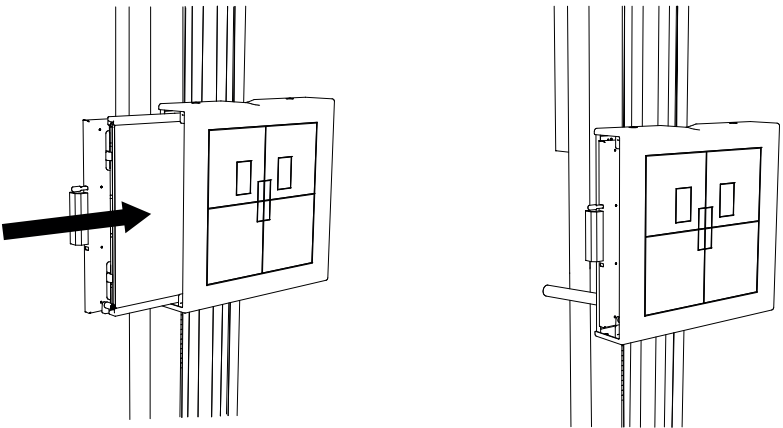

4. Push the detector until the hold-backs are set. Then the detector is in the correct position. Chargeable detectors will start charging when set in this position.

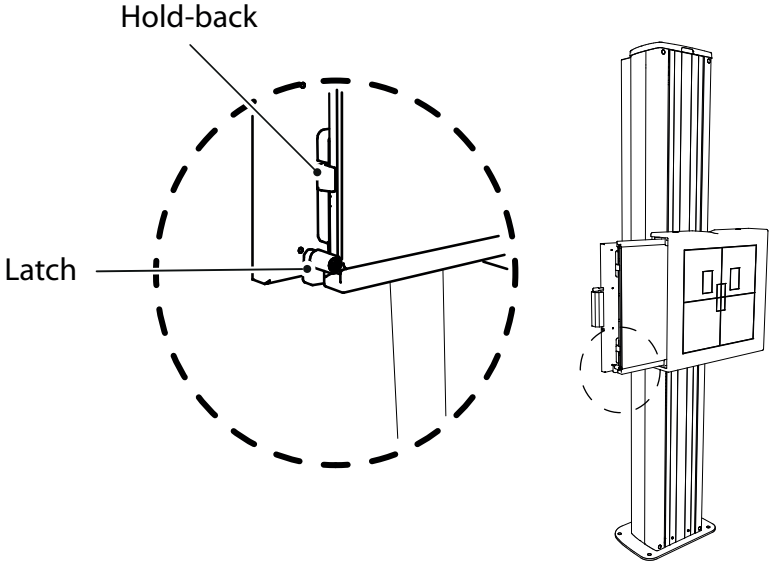

Fig. 3-16

# Theory of Operation

## Functional Description

---

**CAUTION!**

*It is important that the hold-backs lock outside the detector end. Failure to position the detector in the proper position, will lead to incorrect images.*

---

**Note!**

*If the detector or the detector holder is not properly inserted, a warning symbol will be shown at the display.*

---

# Theory of Operation

## Functional Description

---

**Method to remove the 17x17 detector, wallstand**

- 1. Pull the detector tray toward you. Make sure the detector tray is completely brought out.

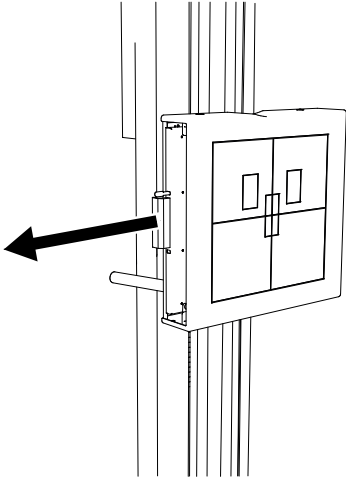

Fig. 3-17

- 2. Hold down the latch, removing the detector from the detector tray as shown below.

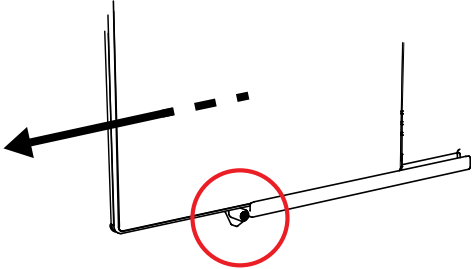

Fig. 3-18

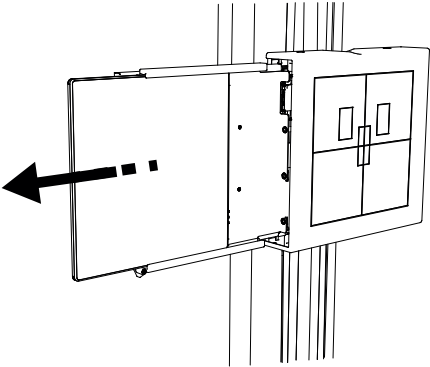

Fig. 3-19

### 3.5.7.5 Grid

#### *Installing the Grid, Removable Grid*

The following procedures are used for installing the grid or when you need to replace the grid.

#### **CAUTION!**

- **Use the grid that is appropriate for exposure conditions (distance, etc).**

**Hold the grid in both hands, with your hands holding the metal on the sides of the grid, and insert the grid along the grid holder rail on the top of the detector tray.**

---

#### **CAUTION!**

- **Properly insert the grid along with the rail. The device may be damaged if not mounted in properly**
- 

#### **Note!**

- When mounting the grid, after confirming that it is right side up, check to make sure that it is mounted correctly with the top surface toward you, as shown below.

*The top surface is the one with the sticker affixed to the metal handle of the grid surface.*

---

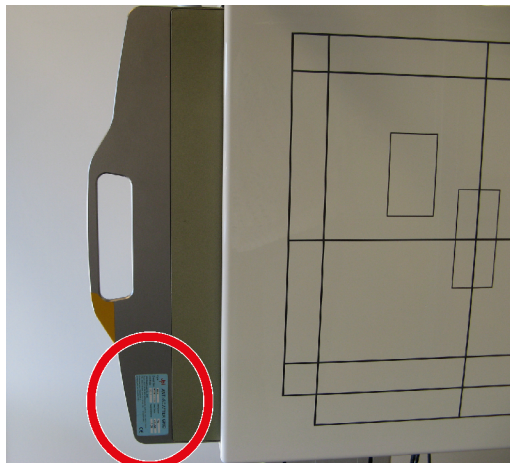

Fig. 3-20 Correct grid mounting

# Theory of Operation

## Functional Description

---

- When mounting the grid, your fingers will come in contact with the detector holder cover. First remove the hands from the cover, and then mount by pressing the grid in by the edges of the metal handles on the grid surface.
- When the grid is mounted correctly in position, there is a peak (click) at the end. After sensing that you have pressed passed that peak, the grid is properly in position.

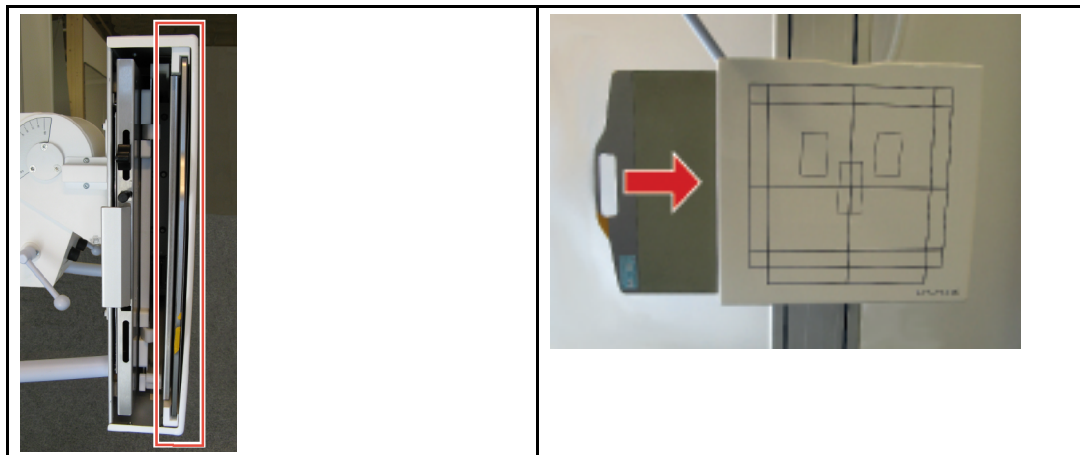

When there is need to replace the grid, or when removing the grid to perform gain calibration, pull the grid in the direction of the arrow by holding the metallic handle on the side of the grid. (See *"Image System Installation/Service Manual"* for gain calibration).

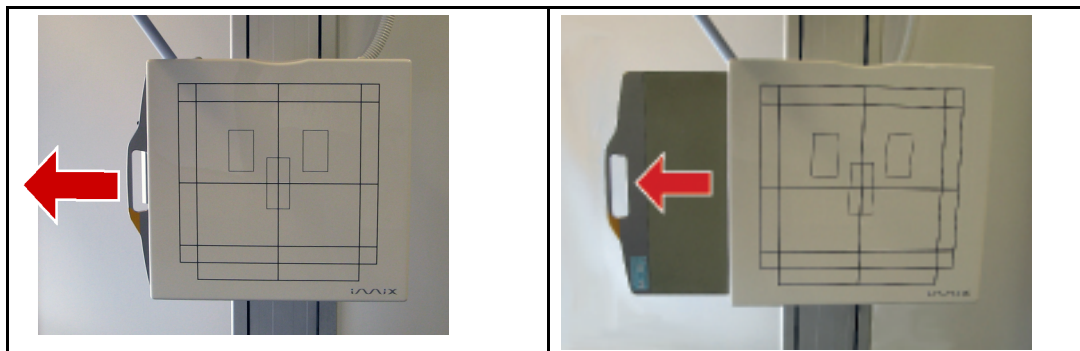



### 3.5.7.6 Collimator Control Handle, Wallstand (option)

**Note!**

*This function is only possible when connected to an X-ray system.*

---

The figure shows the functions of the collimator control handle.

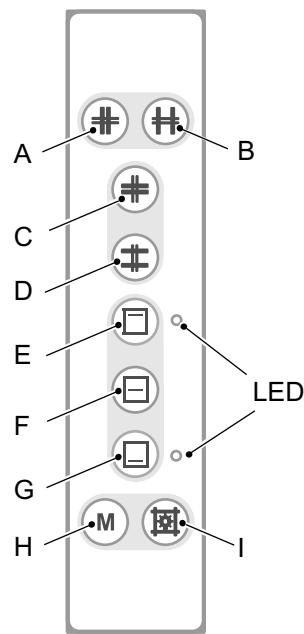

Fig. 3-21 Collimator control handle

- A. Button for closing the format width collimation.
- B. Button for opening the format width collimation.
- C. Button for closing the format height collimation.
- D. Button for opening the format height collimation.
- E. Button for top centering of the collimator light field. LED indicating the selected position.
- F. Button for middle centering of the collimator light field.
- G. Button for bottom centering of the collimator light field. LED indicating the selected position
- H. Button for changing between automatic and manual mode. A long activation of the M button set the light field to cassette size (based on the pre-programmed SID value).
- I. Button for switching the light, the laser line and automatic mode on/off. The light and laser line is automatically switched off via a time switch.

# Theory of Operation

## System techniques

---

### 3.6 System techniques

The system has three different techniques which are described in this chapter. The functionality and features of the techniques is also described in this chapter.

*Note!*

*The available techniques are depending on the actual configuration of the system.*

---

The techniques in the system are:

- *Free Technique*
- *Table Tracking*
- *Wallstand Tracking*

Table and wallstand tracking are both possible against a vertically and horizontally placed detector.

#### 3.6.1 General user interface

The alpha angle is always shown on the display.

In *Free technique* the height (H) is always shown. In *Table* and *Wallstand Tracking Techniques*, the SID is shown toward a horizontally placed detector.

Against a vertically placed detector no height indication or SID is shown.

#### 3.6.2 Free technique

##### 3.6.2.1 General description

The *Free Technique* is the most basic mode in the system. The mode holds no special features or functionality. It is intended as a manual mode with a high level of freedom in positioning and exposure, e.g. for emergency examinations or examinations with the patient sitting in a wheel chair or lying in a bed. The *distance H*, shown in the display, is the distance to the floor.

##### 3.6.2.2 Exposure validation

Exposure is allowed (the interlock relay is closed) if the ceiling stand is standing still and is operating properly (not in an error state).

### 3.6.3 Tracking

There are four different default tracking distances in the system, two for each tracking technique, i.e. *Wallstand* and *Table Tracking Technique*.

The two types for both tracking techniques are against vertically and horizontally placed detectors.

These default distances are set during installation of the system. Which default tracking distance that is used depends on which tracking technique that is chosen on the tube holder and the angle of the X-ray tube. *Wallstand* or *Table Tracking* is selected from the display and an image at the display shows if the wallstand or the table is selected.

The synchronization button below the display, indicates the status.

---

#### **CAUTION!**

***The user shall control if the tracking is activated, or not. This is done by checking if the synchronization button, at the wallstand or the OTC, is lit.***

---

The light indication can be flashing or constant. The light indication will be constant if the system is in the correct position for tracking (normally default tracking distance) and flashing if it is not. If the light indication is flashing, there are two ways to get the system to its correct tracking distance.

1. Move wallstand or table (depending on which tracking is activated).
2. Push and hold the synchronization button at the wallstand or at the OTC.

Tracking movement is performed as long as the movement is activated on the tracked stand, i.e. wallstand or table, the ceiling stand will move to find the correct distance and then continue to track at that distance.

If the tracked stand is already in the desired position, the synchronization button at the wallstand or at the OTC can be pushed and held to get the system to move to the correct position.

When the system has reached the correct distance for tracking, any manual movement on the tube holder (Z-direction) will change the tracking distance to the distance it is placed on when stopping the tube holder movement.

Moving the tube angle will affect the correct distance for tracking if it is moved across the -45 or 45 degree angle.

The correct distance for tracking is then set to the default tracking distance, since it has changed between horizontally and vertically placed detector.

Except for tracking against a vertically placed detector on the wallstand, tracking is always prohibited downward below the safety zone.

# Theory of Operation

## System techniques

---

### 3.6.3.1 Synchronization control/tracking

The automatic tracking is activated at the display.

Activation of the synchronization button will drive the OTC to the position for tracking.

The activation will lead to a synchronization and tracking between the tube holder and the detector.

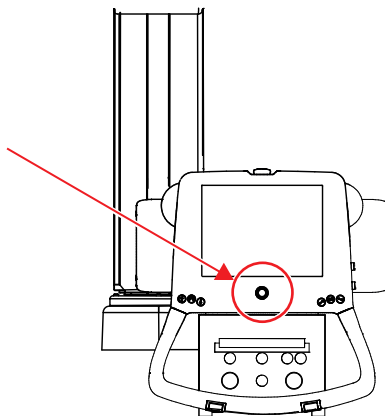

*Fig. 3-22 Synchronization button with indication light — display*

The synchronization button at the display, also comprises a yellow indication light. This light indicates if there is an alignment.

- Permanent yellow light — indicates; *Alignment*.
- Flashing yellow light — indicates; *No alignment*.

### 3.6.3.2 Table tracking technique

#### **General description**

The *Table tracking technique* is intended for examinations against a table.

In this technique the tube holder will track the movements of the table to assist the operator to always keep the distance to the detector.

#### **Table tracking**

The tube holder can track the table detector in two different positions depending on if the detector is placed vertically or horizontally.

The system decides which way, depending on the angle of the X-ray tube.

If the angle is between -45 and +45 degrees, the detector is assumed to be horizontally placed and thereby the default tracking distance for a horizontally placed detector is chosen.

The SID is shown on the display.

If the angle is outside -45 to +45 degrees, the system assumes that the detector is placed vertically and thereby the vertical default tracking distance is chosen.

No SID or height is shown on the display.

The default tracking distances are set during installation of the system.

#### **Note!**

---

*In table tracking technique, the exposure is blocked whenever a wallstand workstation is chosen on the generator.*

---

#### **Table synchronization**

At table synchronization, a predetermined collimator height is set. When tracking, the OTC will seek the determined height.

If the distance: collimator — table, differs from the predetermined, the yellow indication light at the ceiling stand, will flash.

Activate the synchronization button at the ceiling stand, and the OTC will move to the determined SID.

When synchronized, the indication light will stop flashing and shine with a permanent yellow light.

# Theory of Operation

## System techniques

---

### 3.6.3.3 Wallstand tracking technique

#### **General description**

The *Wallstand tracking technique* is intended for examinations against a wallstand.

In this technique the tube holder will track the movements of the wallstand to assist the operator to always keep the correct position to the detector.

#### **Wallstand tracking**

The tube holder can track the wallstand in two different positions depending if the detector is placed vertically or horizontally.

The system decides which way depending on the angle of the X-ray tube.

If the angle is between -45 and +45 degrees the detector is assumed to be horizontally placed and the default tracking distance for a horizontally placed detector is chosen.

The SID is shown on the display.

If the angle is outside -45 to +45 degrees the system assumes that the detector is placed vertically and the vertical default tracking distance is chosen.

No SID or height is shown on the display. The default tracking distances are set during installation of the system.

#### **Note!**

---

*In Wallstand tracking technique, the exposure is blocked whenever a table workstation is chosen on the generator.*

---

### Wall stand synchronization



### **WARNING!**

---

**Before performing any wall stand tracking, assure that the wall stand indication light is lit and thereby, that the wall stand is activated.**

---

At wall stand synchronization, the collimator reticle shall be aligned with the detector cross.

When performing fast or long movements of the wall stand detector, it may occur that the collimator does not synchronize with the wall stand detector. The automatic wall stand tracking may not make it all the way and the indication light will start flashing.

In this case, activate the synchronization button at the wall stand, see Fig. 3-23 *Wall stand synchronization button*.

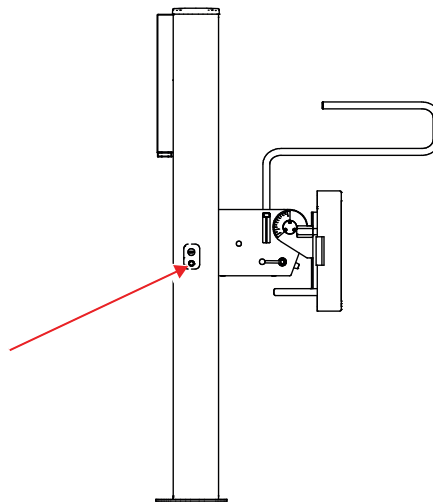

Fig. 3-23 *Wall stand synchronization button*

Then the tracking will carry out the full movement and synchronize. The indication light will shine permanently.

# Theory of Operation

## System techniques

### 3.6.3.4 Tracking (horizontal/vertical)

#### **Tracking operation when horizontal**

- For the detector holder of the table when the *Table icon button* is active:
- When the *Wallstand icon button* is active and the detector holder of the wallstand tilt model is positioned at 90 degrees:

Tracking operation is only performed when the alpha angle of the display is between +45 and -45 degrees. When performing horizontal tracking of each device, check that the alpha angle display is within the above range.

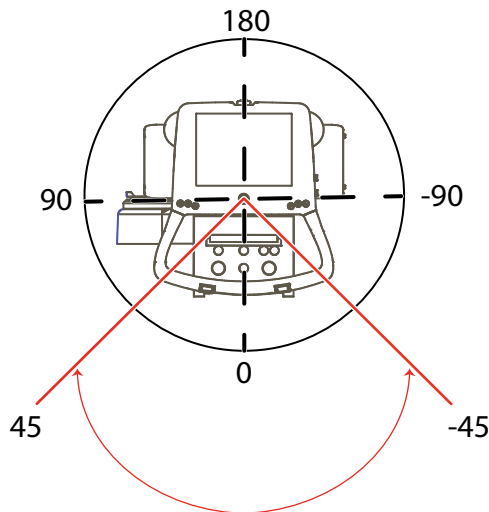

Fig. 3-24 Tracking operation when horizontal

#### **Tracking operation when vertical**

- For the holder of the wallstand when the *Wallstand icon button* is active:
- When the *Table icon button* is active and when using the vertical on the table:

Tracking operation is only performed when the alpha angle of the display is between +46 and +134 degrees and between 46 and 134 degrees. When performing vertical tracking of each device, check that the alpha angle display is within the above range.

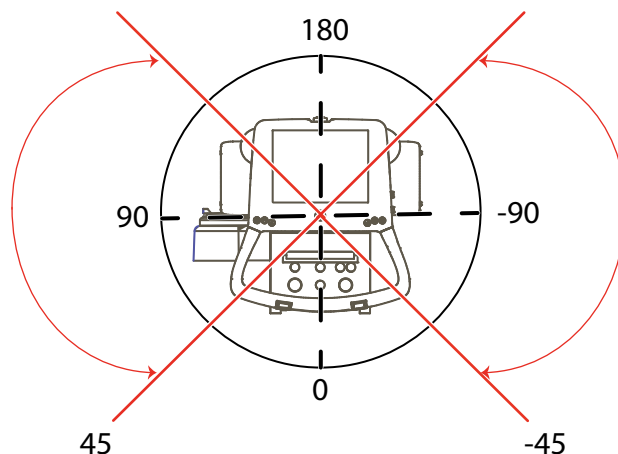

Fig. 3-25 Tracking operation when vertical



### 3.7 Software Design

#### Architectural Goals and Constraints

#### Basic Concepts

The System is built with a number of separate subsystems, acting as individual units in the System.

The different subsystems are:

- *The High voltage generator.*

Responsible for the emission of X-rays.

- *The Cabinet.*

The interface between the image system and other parts in the System. Responsible for the tracking of Table and Wallstand.

- *The Ceiling unit.*

Responsible for handling of the ceiling support. Important functions for this sub-system are, moving Z up/down, X, Y, Alpha and Beta. The display is mounted in this subsystem but controlled by the Cabinet.

- *The Wallstand.*

Responsible for holding the detector for chest examinations. Also possible to move the detector in Z and tilt direction.

- *The Table.*

Holding the detector and a patient. Moving the Table up/down, detector and handling of a brake for the Table top.

# Theory of Operation

## Software Design

---

## 4 Installation

### 4.1 General

This chapter describes how to unpack and install the product. Follow the instructions given in this chapter and use the installation checklist, located in Appendix C.

After completing the installation, fill in the Installation Report and send it back to Arcoma AB. If not, the time of guarantee will be considerably reduced.

**Note!** \_\_\_\_\_

*Surrounding equipment, that is not the manufacture equipment, shall follow the standard IEC 60601-1-2 regarding electromagnetic compatibility.*

---

**Note!** \_\_\_\_\_

*It is the responsibility of the one who combines the Product with other equipment, to secure that the use of the combination is in compliance with MDD 93/42/EEC or other directives that may be mandatory on the market in question.*

---

**Note!** \_\_\_\_\_

*Refer to the Product Planning Guide for information about installation location, space and transfer.*

---

# Installation

## Precautions, Installation

---

### 4.2 Precautions, Installation



**WARNING!**

*Do not switch on the power, before the cabling is checked for damage, completely installed and connected according to the installation chapter.*

---



**WARNING!**

*To prevent dangerous situations, make sure that only formally trained service engineers remove the cover or touch the inside of the equipment (except when the front cover is opened to replace the grid).*

---



**WARNING!**

*When working on the image receptor holder, be sure to use fixing bolts to fix the holder to be the main unit frame. If the holder falls accidentally while work is being carried out, it may fall against the worker and result in serious injury.*

---



**WARNING!**

*Electrical shock. Covers removed, exposure to electrical shock.*

---



**WARNING!**

*Be careful not to touch the power line while performing work, such as voltage measurement, that requires the power supply to be turned ON.*

---



**WARNING!**

*Be sure to keep the power turned OFF while performing work that involves contact with the circuit boards, connectors, cables, or other electronic parts in the System. If the power is kept ON, a serious accident may occur.*

---



**WARNING!**

*Check that the System is grounded in a correct way.*

---



### **WARNING!**

---

**Check that the cables are correctly connected and free from damage**

---



### **WARNING!**

---

**When accessing a motor or other driving parts, be careful to ensure that no parts of your body or items of your clothes get caught. Otherwise, you may be injured.**

---



### **WARNING!**

---

**Be aware of live parts when the covers are removed.**

---

### **CAUTION!**

---

- **Danger or risk for injuries if installation instruction is not followed**
  - **When installing the System, follow the installation procedure described in this chapter, see also Installation checklist, Appendix C.**
  - **When installing the System, pay attention to the power supply frequency, voltage, and allowable current.**
  - **Static electricity can damage the electronic circuits. Handle the main unit and removed electronic parts carefully during repair.**
  - **Be sure to wear a grounding strap when handling a circuit board.**
  - **Store spare screws and other parts of this carefully. Using the System with screws removed, may cause accidents.**
  - **If a failure occurs on this, turn OFF the power and contact your nearest service representative.**
  - **Do not use any flammable or explosive gases near the.**
  - **Do not move the device with the power and other cables connected. Doing so may cause the power and other cables to get caught, causing the System to drop or fall, which may result in injury.**
  - **When installing this in a different location, contact us or our designated dealer.**
- 

### **CAUTION!**

---

**All mains supply cables are allowed to be changed only by engineers trained by supplier.**

---

### **CAUTION!**

---

**Remaining energy may exist when the equipment is switched off. Always wait at least 15 seconds before working on the System.**

---

# Installation

## Precautions, Installation

---

**CAUTION!**  
*Be aware of possible squeezing hazards when the covers are removed.*

---

**CAUTION!**  
*Placing Covers: After installing covers, check the tightness of the fixing screws. In particular, when you have to tighten multiple screws, check that all screws have been tightened.*

---

**CAUTION!**  
*When disassembling/assembling this equipment, follow the specified procedures. Be sure to turn off the main unit power source breaker and remove the power cable from the main unit.*

---

**CAUTION!**  
*If the power supply voltage is unstable and falls by 10% or more compared to the specified voltage, internal devices malfunctions may result in unsuccessful X-raying.*

---

**CAUTION!**  
*After installation or service, protective earth measurements shall be performed.*

---

**CAUTION!**  
*Keep the Table top in proper height in Installation/Maintenance.*

---

**CAUTION!**

- Do not place objects under the Table when you do not use it for a long period of time.*

*Due to the elevating mechanism, the Table automatically falls down a little (approximately 10 mm/day). If falling much more, please contact service personnel.*

---

**Note!**  
*For a safe and reliable function of the System, it is crucial to follow the installation instructions regarding the insulation.*

---

**Note!**

---

*The insulation kit is designed to isolate System components, e.g. System cabinet, Table, Wallstand and Ceiling stand from the hospital building.*

*The insulation kit will prevent stray currents from reaching the System e.g. via screw attachments. Stray currents can be present e.g. in reinforcement bars or in water pipes in a building. These currents can be of several hundred amperes and can affect the leakage current from the System to the patient and thereby the safety for patient and user. Stray currents in the building shall be regarded as a failure in the building but the insulation kit provides an extra safety barrier.*

*The insulation kit will also prevent unwanted ground loops due to e.g. electrical contact through the wall or floor lead X-ray shielding via screw attachments of the System components.*

---

# Installation

## Tools Required

---

### 4.3 Tools Required

#### 4.3.1 Standard Tools

- Standard hand tools and service tools
- Tools for unpacking
- Dynamometer (0–400 N)
- Torque wrench (15–47Nm)
- Multimeter
- Digital water level
- Rotation laser
- Allen keys (metric)
- Steel straight
- Hammer drill
- Lift
- Leakage current tester for measurements according to IEC 60601-1
- Assorted cable ties
- Protective ground wire tester for measurements according to IEC 60601-1
- Installation tool
- Loctite 243
- Tape
- Service PC
- Service cable (See 12 *Spare Parts*)
- Working gloves
- Circlip pliers for external circlips
- Customized Allen keys



Fig. 4-1



### 4.4 Service PC

System requirements:

- 128Mb Internal memory
- 100 Mbyte free disk space
- Minimum 1.6 Ghz processor
- CD drive
- 1pc Com port or 1pc USB port with a RS232 converter
- CD/RW or USB (USB stick)
- Windows 2000 or later
- Microsoft. NET 2.0 + SP1

# Installation





## Tightening Torque

---

### 4.5 Tightening Torque

At installation, all screws shall be tightened with the moment (Nm) shown in the Table below, according to ISO 898-1.

10% deviation is permitted.

Nominal Thread Diameter	Screw Material				
	Iron/Steel				
	Hardness Rating				
					
	Tightening Torque (ft-lb)				
M3	0.3	0.6	0.9	1.3	1.6
M3.5	0.5	0.9	1.4	1.99	2.4
M4	0.8	1.3	2.1	2.95	3.6
M5	1.6	2.7	4.2	5.97	7.2
M6	2.7	4.5	7.2	10.3	12.5
M8	6.6	11	17.7	24.3	29.5
M10	12.5	21.4	34.7	47.9	58.3
M12	22.1	37.6	59.7	84	100.3

### 4.6 Shipping/Receiving

#### 4.6.1 Receiving

Verify that the site is ready for installation.

Remove the tops and the sides of the crates.

Inspect the equipment for transport damage immediately upon arrival at its destination. If there is any damage, save the packing material and notify the transport company at once.

To determine whether the complete shipment has arrived, compare items received to those listed on the shippers packing list and the Manufacturer order.

Any discrepancies should be reported to:

Virtual Imaging, Inc.  
A Canon Company  
5600 Broken Sound Blvd.  
Boca Raton, FL 33487  
Toll Free: 866.288.9729  
Main: 561.893.8400  
Fax: 561.893.8401

#### 4.6.2 Storage Precautions

**CAUTION!** \_\_\_\_\_

***Store the System in a place where it will not be exposed to water.***

---

**CAUTION!** \_\_\_\_\_

***Store the System in a place where atmospheric pressure, temperature, humidity, ventilation, sunlight, dust, salt, or air containing sulphur will not adversely affect the equipment.***

---

**CAUTION!** \_\_\_\_\_

***Avoid placing the System on angled surfaces, and subjecting it to vibration, shock (including during transportation) and other factors that may impair stability.***

---

#### 4.6.3 Return Authorizations

Goods returned for credit, exchange or repair will not be accepted by the Manufacturer unless written authorization has been issued. Contact Manufacturer at the above address for return authorizations.

# Installation

## Shipping/Receiving

### 4.6.4 OTC

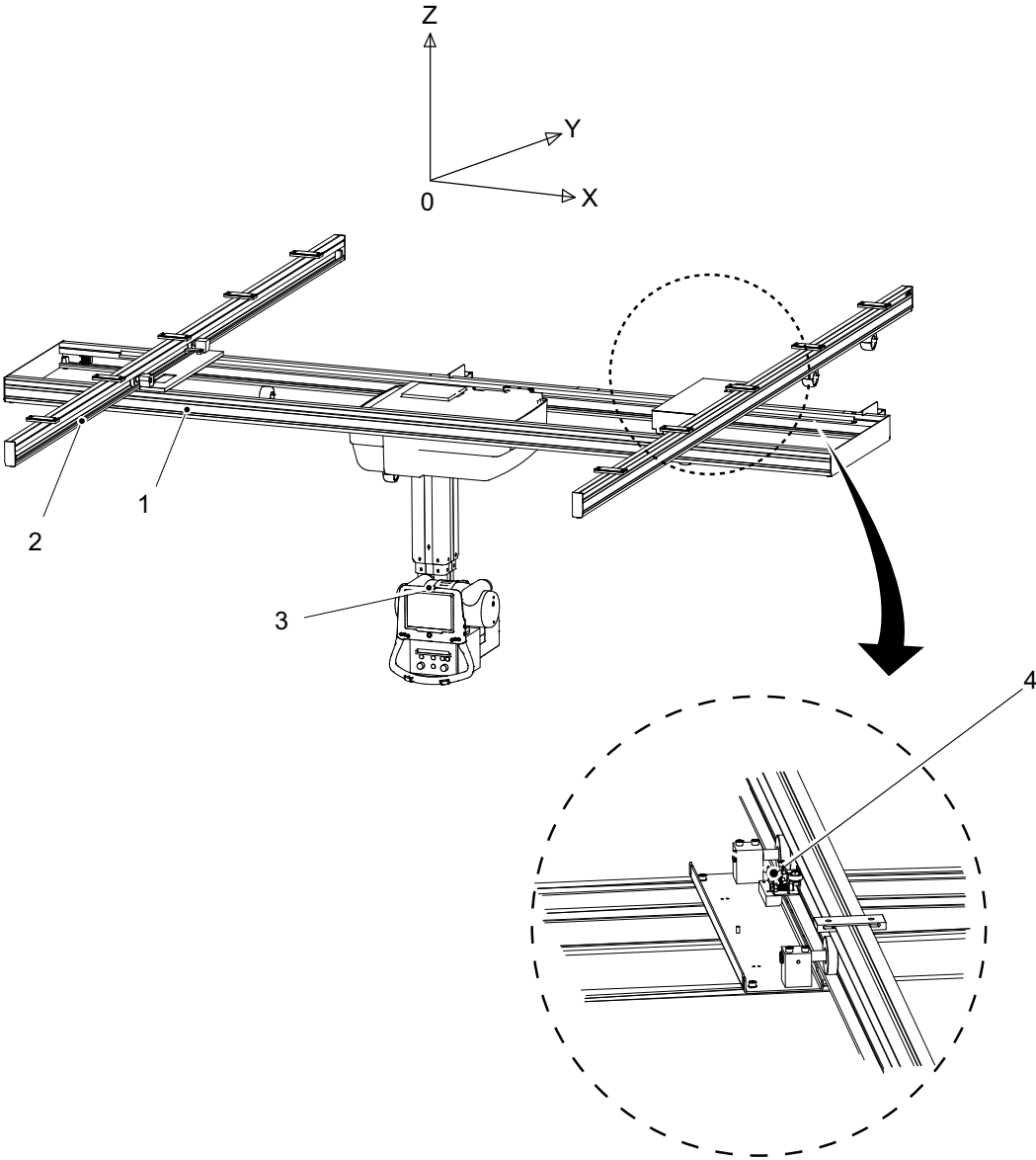
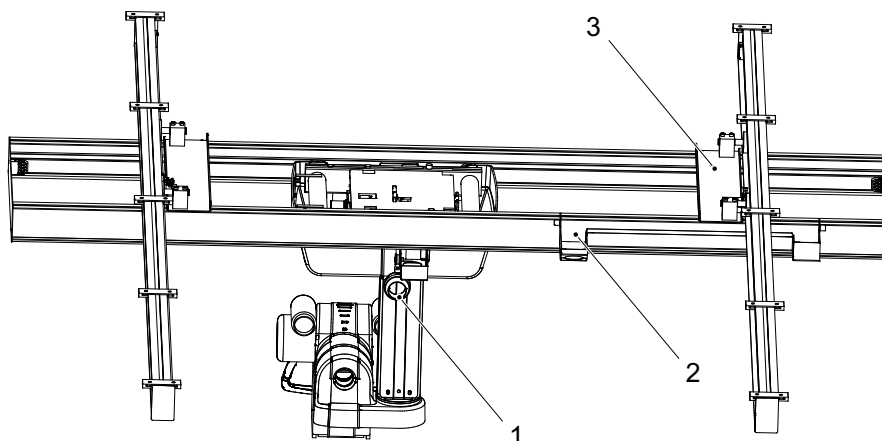

Fig. 4-2 OTC details

- 1. Traverse rail (X)
- 2. Ceiling rail (Y)
- 3. Emergency stop
- 4. Brake



*Fig. 4-3 OTC details*

1. Cable carriage
2. Cable channel
3. Distance plate

# Installation

## Mechanical Installation of OTC

### 4.7 Mechanical Installation of OTC

#### 4.7.1 Ceiling Rails Y

Check that needed fixation point are present in the ceiling.

The ceiling must be free from hanging and extruding objects. The ceiling unit is moving and requires free space.

Spread the pre-installed fixation blocks on the ceiling rail Y, with the same distance (A) as the fixation points in the ceiling, see figure and table below.

The distance (A) between the fixation points depends on the length of the traverse rails Y.

**Note!**

*The ceiling suspended unit rails shall also be parallel +/- 1 mm.*

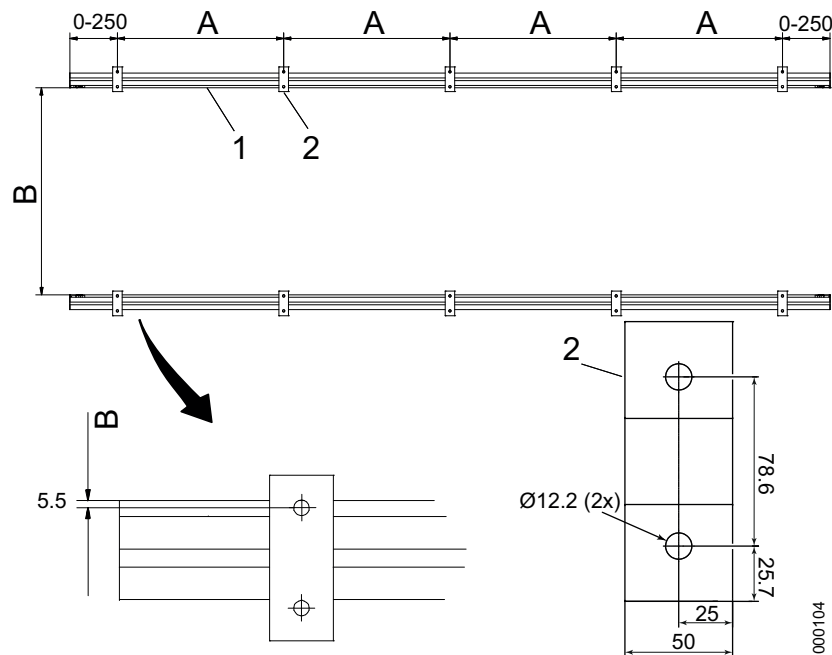

Fig. 4-4 Ceiling rails Y

1. Ceil suspended unit rail (Y)
2. Fixation block

Table 4-1

Length traverse rail X	3000 mm	2748 mm (low ceiling)
Measure A	850-1100 mm	850-1100 mm
Measure B	1800-2200 mm	2778 mm

Spread the pre-installed fixation blocks on the ceiling rail Y, with the same distance (A) as the fixation points in the ceiling.

The distance (A) between the fixation points depends on the length of the traverse rails Y, see Fig. 4-4 *Ceiling rails Y* and Table 4-1 .

Lift up the ceiling rails Y and bolt the fixation blocks into the Unistrut or similar with the enclosed M10 screws and washer. Also install the insulation plates and cases on the fixation blocks, see figure below.

### Note!

*The insulation kit is designed to isolate System components, e.g. System cabinet, Table, Wallstand and Ceiling stand, from the hospital building.*

*The insulation kit will prevent stray currents from reaching the System e.g. via screw attachments. Stray currents can be present e.g. in reinforcement bars or in water pipes in a building. These currents can be of several hundred amperes and can affect the leakage current from the System to the patient and thereby the safety for patient and user. Stray currents in the building shall be regarded as a failure in the building but the insulation kit provides an extra safety barrier.*

*The insulation kit will also prevent unwanted ground loops due to e.g. electrical contact through the wall or floor lead X-ray shielding via screw attachments of the System components.*

The ceiling rail Y must be level in X, Y and Z direction  $\pm 1$  mm. If not use the enclosed shims.

The distance (B) between the ceiling suspended unit rails Y is depended on the length of the traverse rails X, see Fig. 4-4 *Ceiling rails Y*.

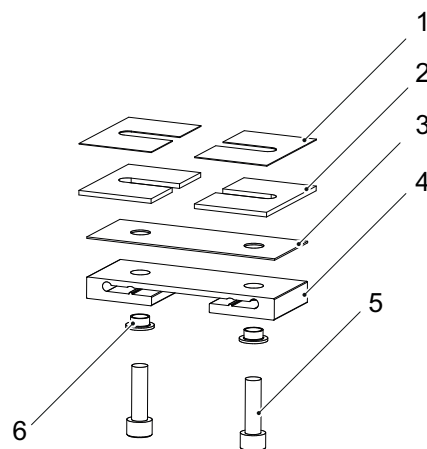

Fig. 4-5 *Mounting ceiling rail Y*

- |                     |                       |
|---------------------|-----------------------|
| 1. Shims            | 4. Fixation block     |
| 2. Shims            | 5. Installation screw |
| 3. Insulation plate | 6. Insulation case    |

# Installation

## Mechanical Installation of OTC

### 4.7.2 Traverse Rail X

*Note!*

One of the traverse rail X contains a steel bar for the brakes. See the room layout to know the orientation of the steel bar for the brakes in the room.

Loosen the screws (4) and push on the flat bar (3), with the distance plate (2), onto the traverse rail X (1) according to figure.

The distance (B) between the distance plates is depended on the length of the traverse rail X, see Fig. 4-4 *Ceiling rails* and Table 4-1

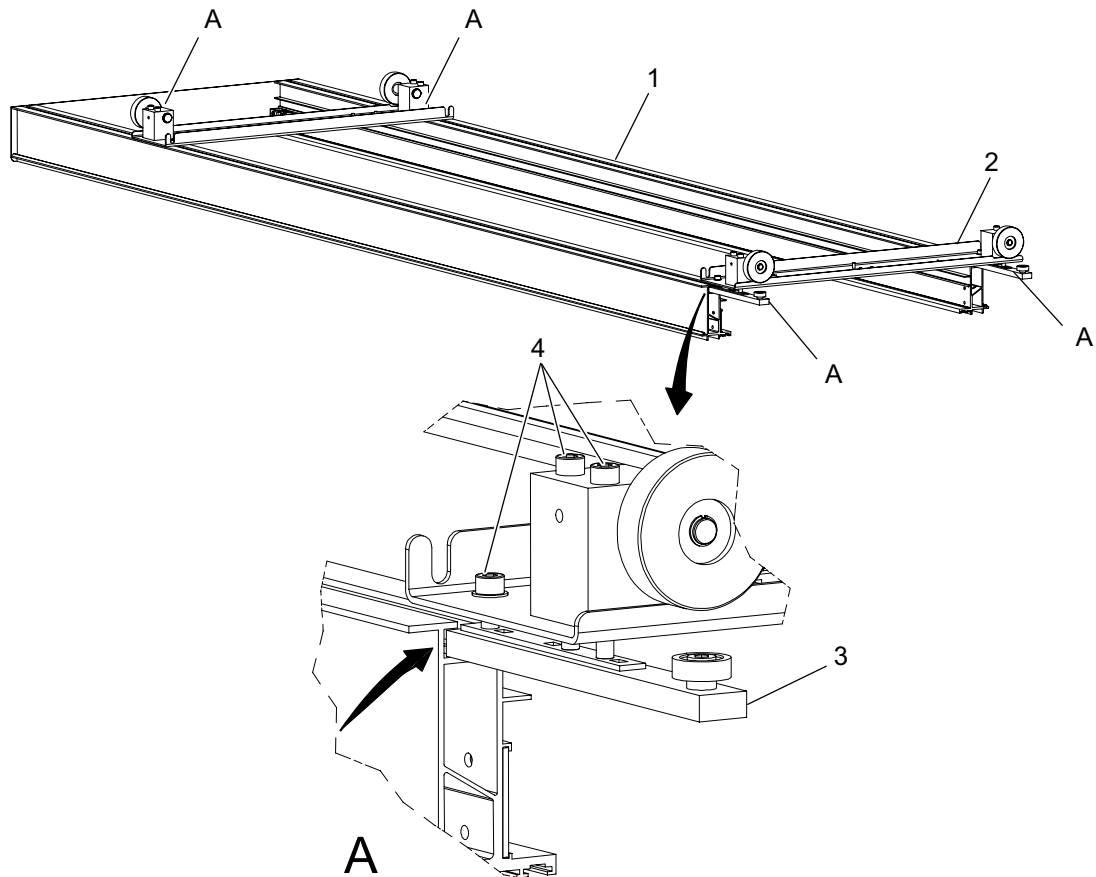

Fig. 4-6 Traverse rails X

- |                    |             |
|--------------------|-------------|
| 1. Traverse rail X | 3. Flat bar |
| 2. Distance plate  | 4. Screws   |



See figure below for the distance between the traverse rails X.

The traverse rails X must be parallel in X direction  $\pm 2$  mm.

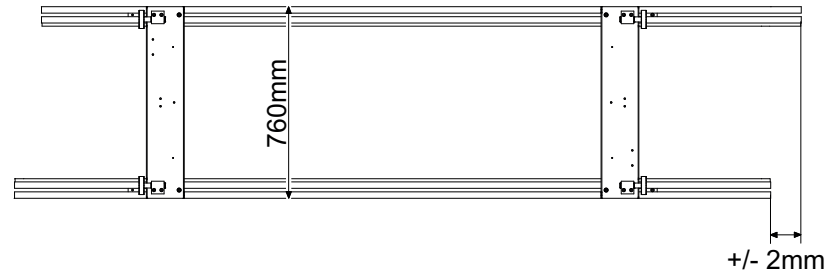

*Fig. 4-7 Distance between traverse rails X*

Install the end covers on the traverse rails X.



*Fig. 4-8*

Before installing the traverse rails X, check that the steel bar for the brakes is placed in the correct traverse rail X.

The placement of the steel bar for the brakes depends on the orientation of the ceiling wagon to secure the function of the brake X.

The steel bar for the brakes has to be placed on the same side of the ceiling wagon as the brake X.

# Installation

## Mechanical Installation of OTC

---

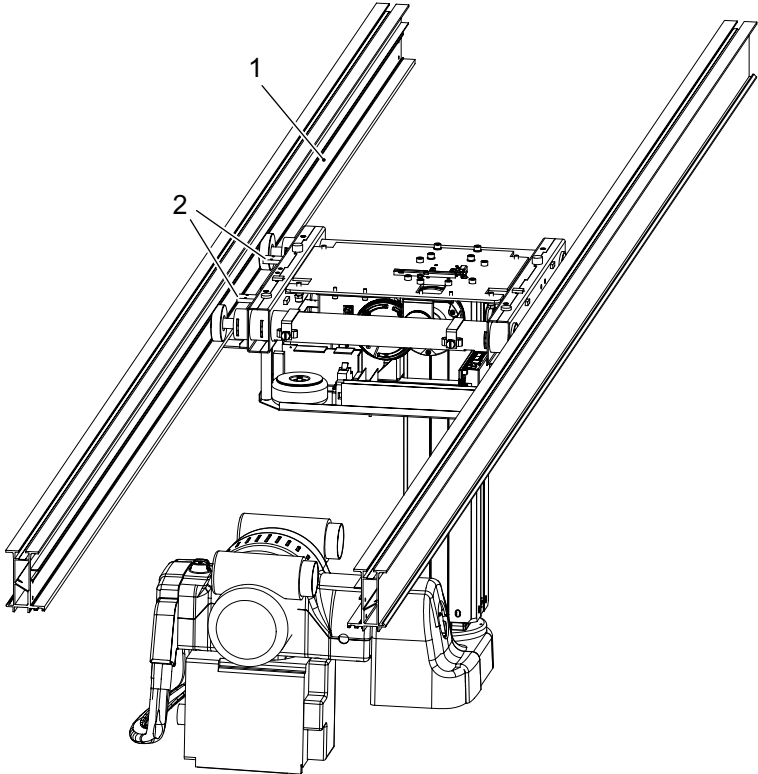

Fig. 4-9 Brake steel bars

- 1. Steel bar for the brakes
- 2. Bracket for brake X.

Lift up the traverse rails X and check that the wheel on the flat bar, see Fig. 4-6 *Traverse rails X*, ends up into the track of the ceiling rail Y.

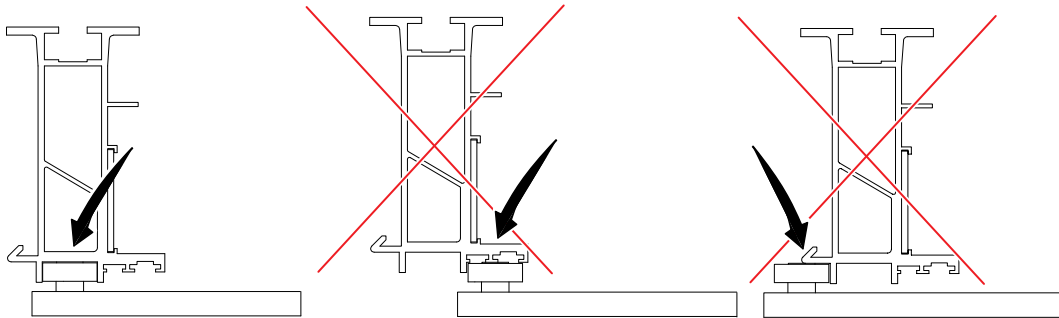

Fig. 4-10 *Mounting traverse rail X*

When the traverse rail X is in place, push out the wheels on the distance plates into the tracks on the ceiling rails Y, see picture A and B in Fig. 4-12 *Locking the wheels*.

The wheels must not be outside the tracks or too close to the ceiling rail Y, see figure below.

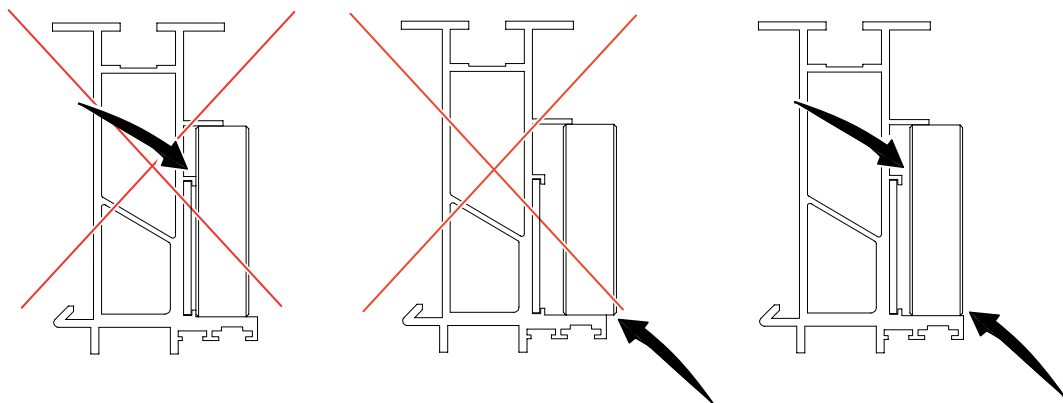

Fig. 4-11 *Mounting of wheels*

# Installation

## Mechanical Installation of OTC

---

Install the set screws to lock the wheels when they are in position, also install the clamp ring into the shaft groove.

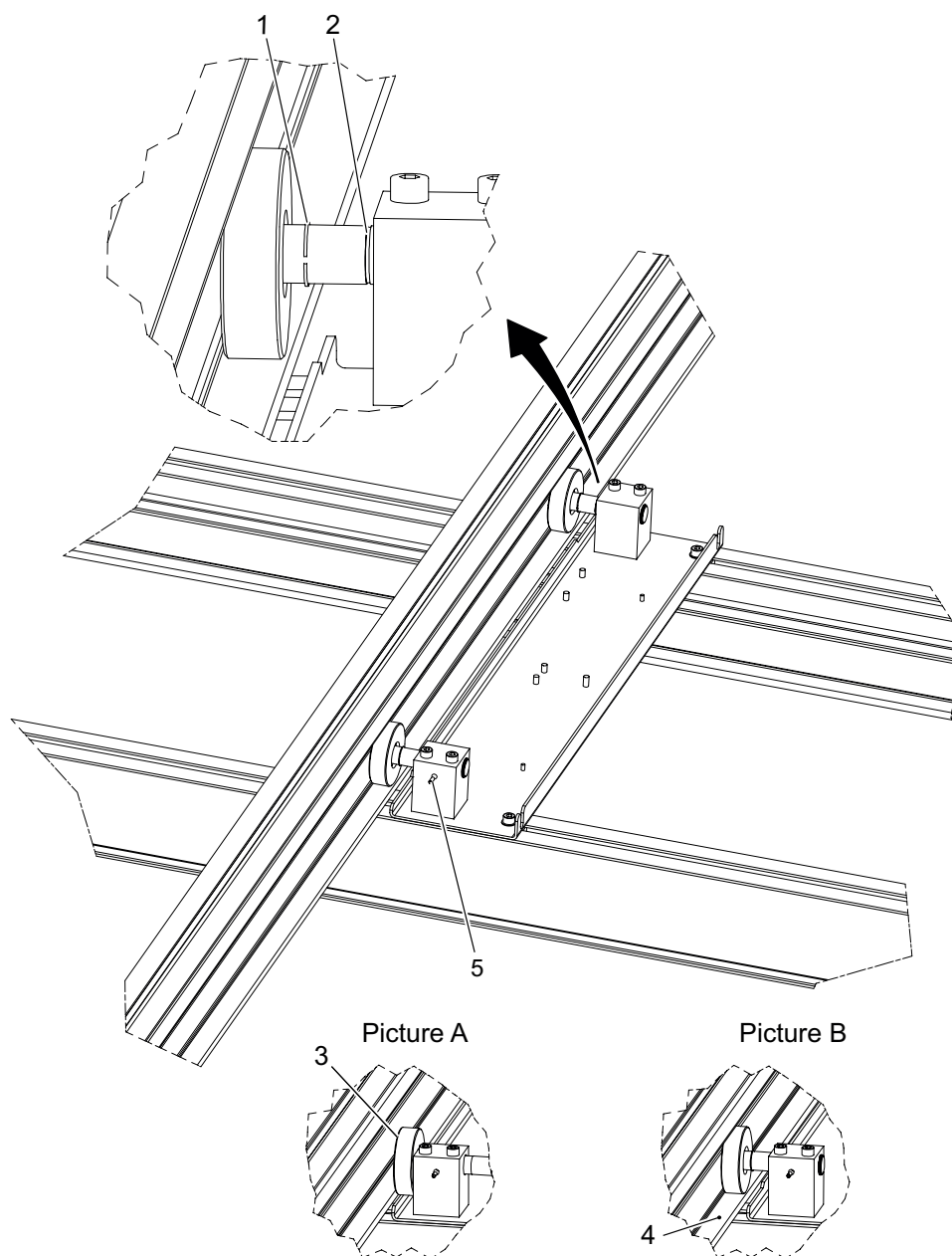

Fig. 4-12 Locking the wheels

1. Clamp ring
2. Shaft groove
3. Wheel

4. Track
5. Set screw

### 4.7.3 Y Brake

*Note!*

*Having installed the brakes, it will not be possible to move the traverse until after the power-up.*

Install the Y brakes on the distance plate, one on each distance plate.

Install the Y brakes against the steel bar for the brakes on the ceiling rail Y.

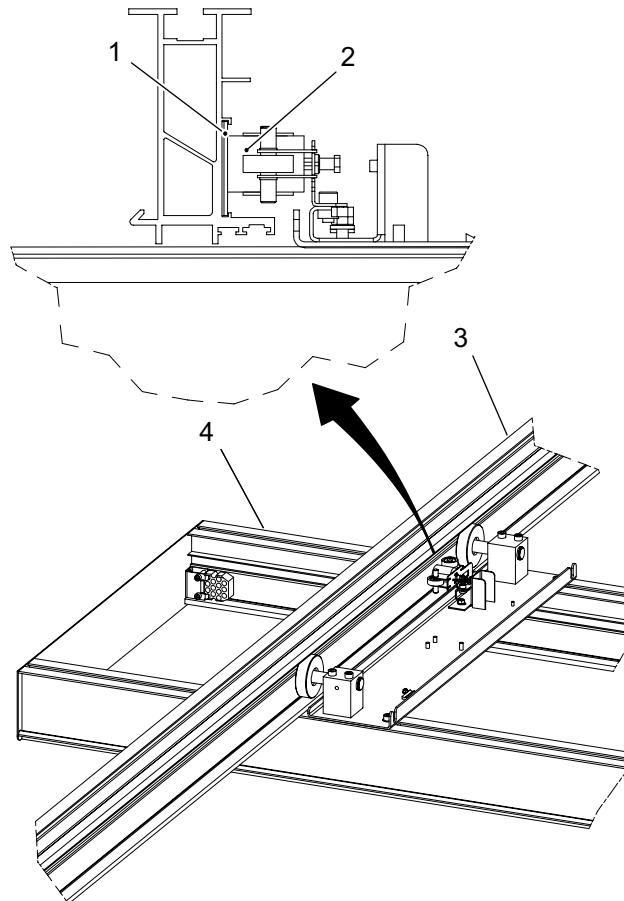

Fig. 4-13 Installing the Y brakes

- |                             |                    |
|-----------------------------|--------------------|
| 1. Steel bar for the brakes | 3. Ceiling rail Y  |
| 2. Y Brakes                 | 4. Traverse rail X |

# Installation

## Mechanical Installation of OTC

---

### 4.7.4 Ceiling Wagon

*Note!* \_\_\_\_\_  
Check the room layout for orientation of the ceiling wagon.

---

The ceiling wagon can either be lifted with the four enclosed rings (1), this shall be installed on top of the wagon, or lifted on the pallet with an industrial truck.

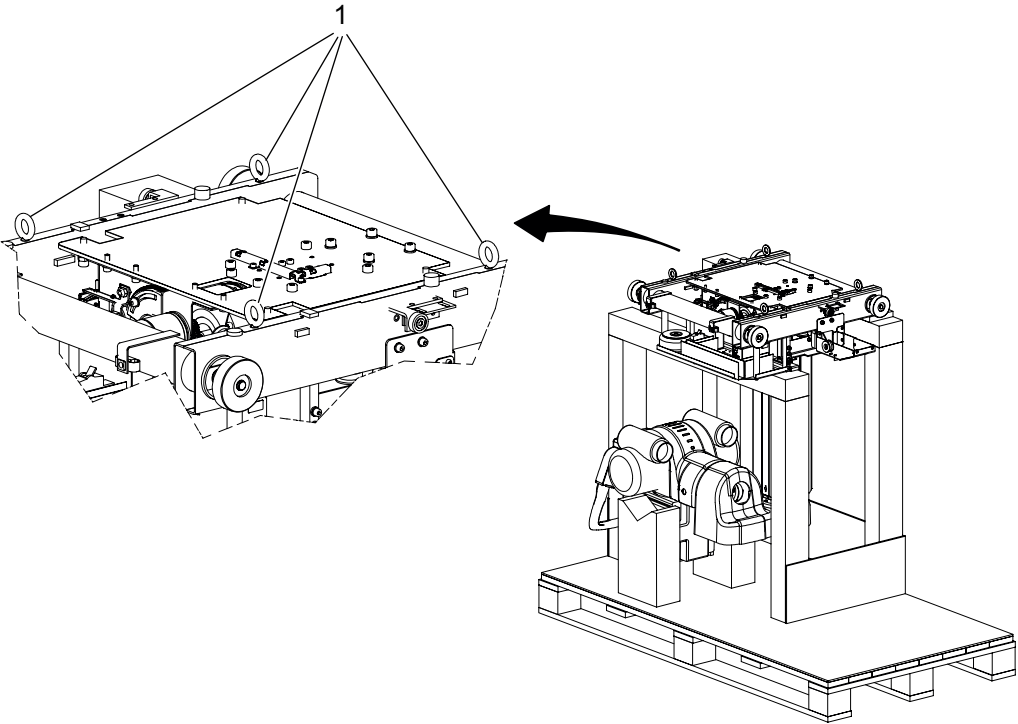

Fig. 4-14 Lifting ceiling wagon

# Installation

## Mechanical Installation of OTC

Lift up the ceiling wagon and check that the side position bearings ends up into the track of the traverse rails X, see figure below and Fig. 4-16 *Wheel position*.

Check that the steel bar for the brakes is placed on the correct side of the ceiling wagon.

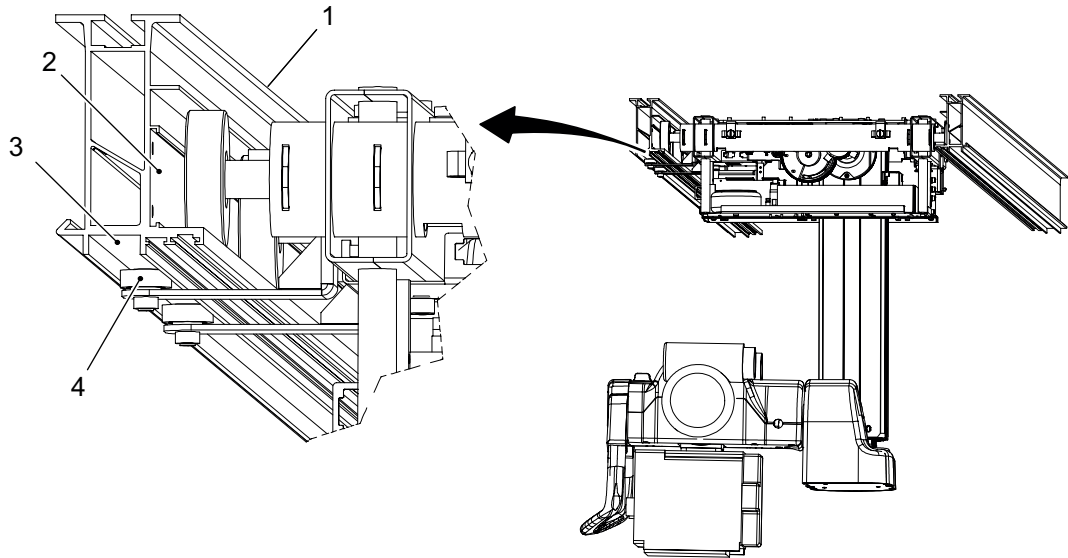

Fig. 4-15 Ceiling wagon

- |                             |                           |
|-----------------------------|---------------------------|
| 1. Traverse rail X          | 3. Track                  |
| 2. Steel bar for the brakes | 4. Side position bearings |

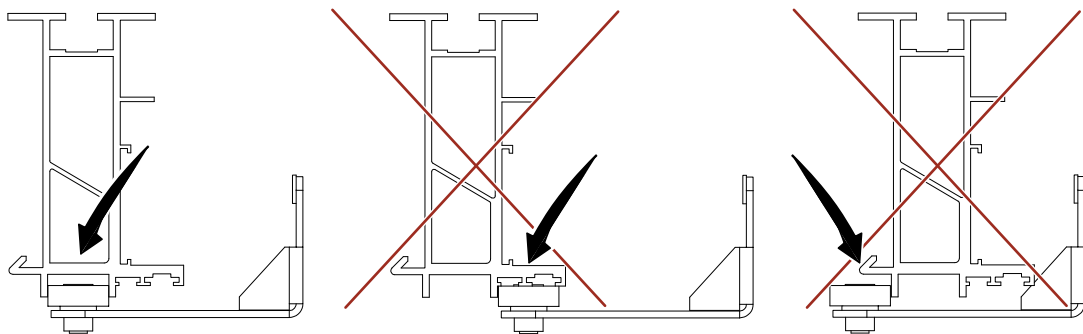

Fig. 4-16 Wheel position

# Installation

## Mechanical Installation of OTC

---

Push out the wheels into the tracks on the traverse rails X, see picture A and B in Fig. 4-12  
*Locking the wheels.*

The wheels must not be outside the tracks or too close to the traverse rails X, see Fig. 4-11  
*Mounting of wheels.*

When the wheels are in position, install the clamp rings into the shaft groove, see figure below.

Check that the ceiling wagon runs smoothly.

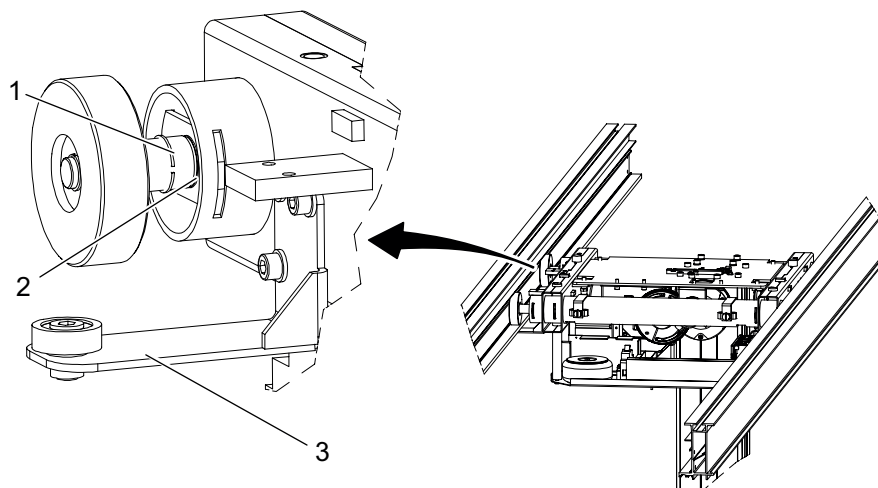

Fig. 4-17

1. Clamp ring
2. Shaft groove

3. Side position bearings



### 4.7.5 Install Safety Clamp Ring

Move the OTC manual to all positions in X, Y and Z direction and make sure it runs smoothly and sounds OK.

When the position is absolutely decided; Push the safety clamp ring (1) toward the clamp ring (2) as far as possible.

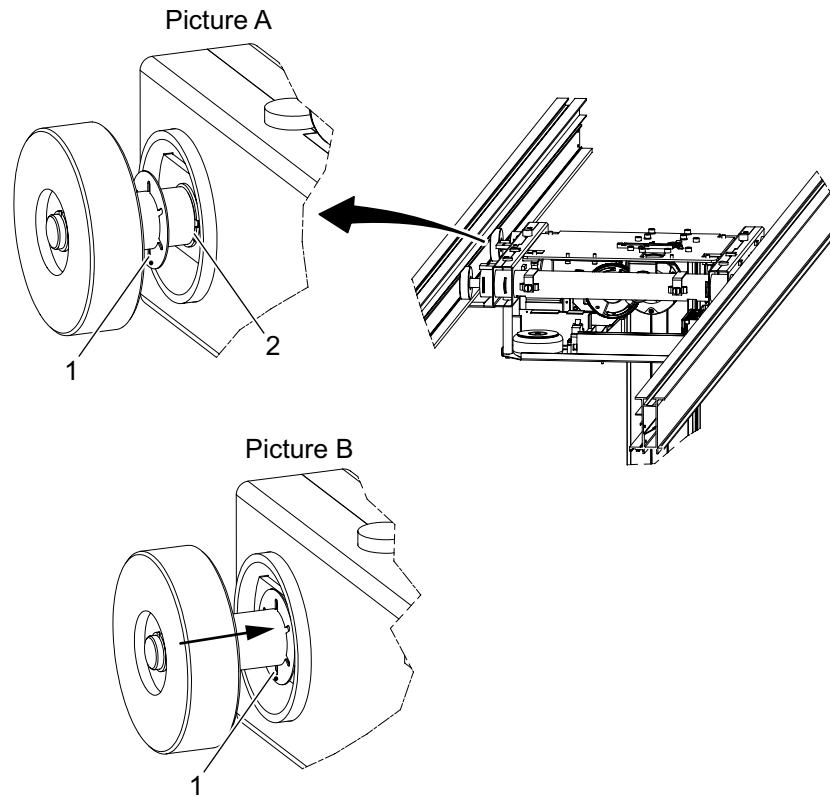

Fig. 4-18 Safety clamp ring

1. Safety clamp ring
2. Clamp ring

# Installation

## Mechanical Installation of OTC

---

### 4.7.6 X-Brakes

*Note!*

*Having installed the brakes, You will not be able to move the Ceiling stand until after the power-up.*

Install the X brakes on the bracket on the ceiling wagon, see picture 1 in figure below, one on each bracket.

Install the X brakes against the steel bar for the brakes on the traverse rail X.

Connect both the X brakes according to picture 2, in Fig. 4-19 X-brakes.

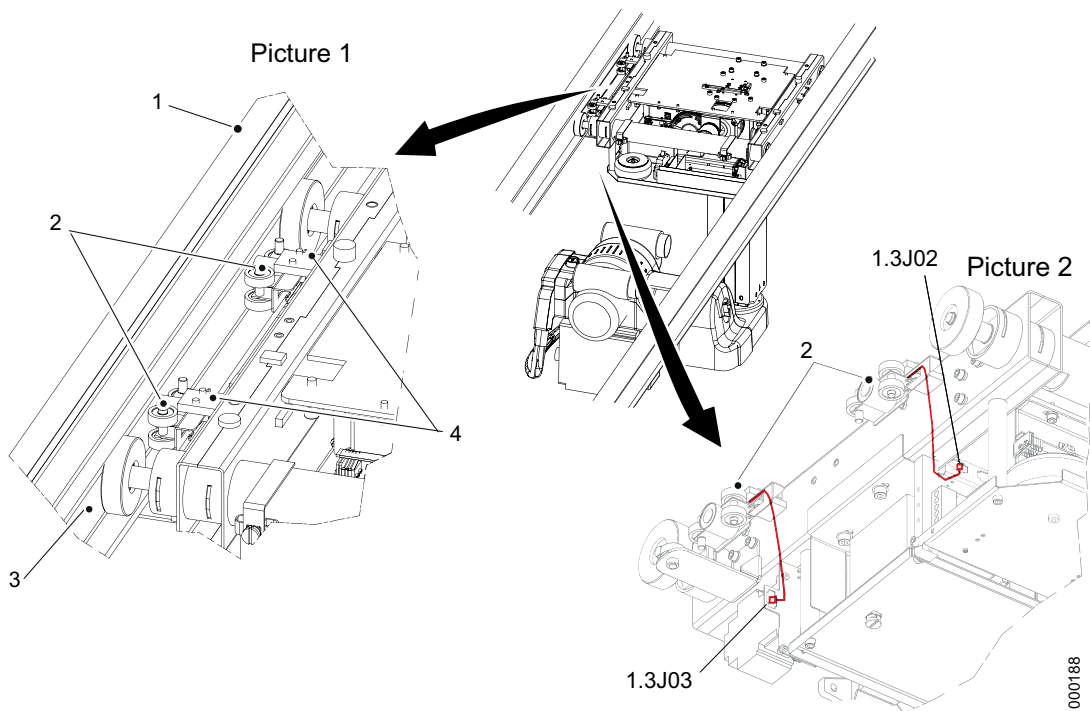

Fig. 4-19 X-brakes

- |                    |                             |
|--------------------|-----------------------------|
| 1. Traverse rail X | 3. Steel bar for the brakes |
| 2. Brake X         | 4. Bracket for brake X      |

### 4.7.7 Cable Channel

Depending on the orientation of the ceiling wagon in the room, the cable channel can be installed on the left or the right side of the ceiling wagon.

Figure below shows how right respective left hose frame of the cable channel looks like.

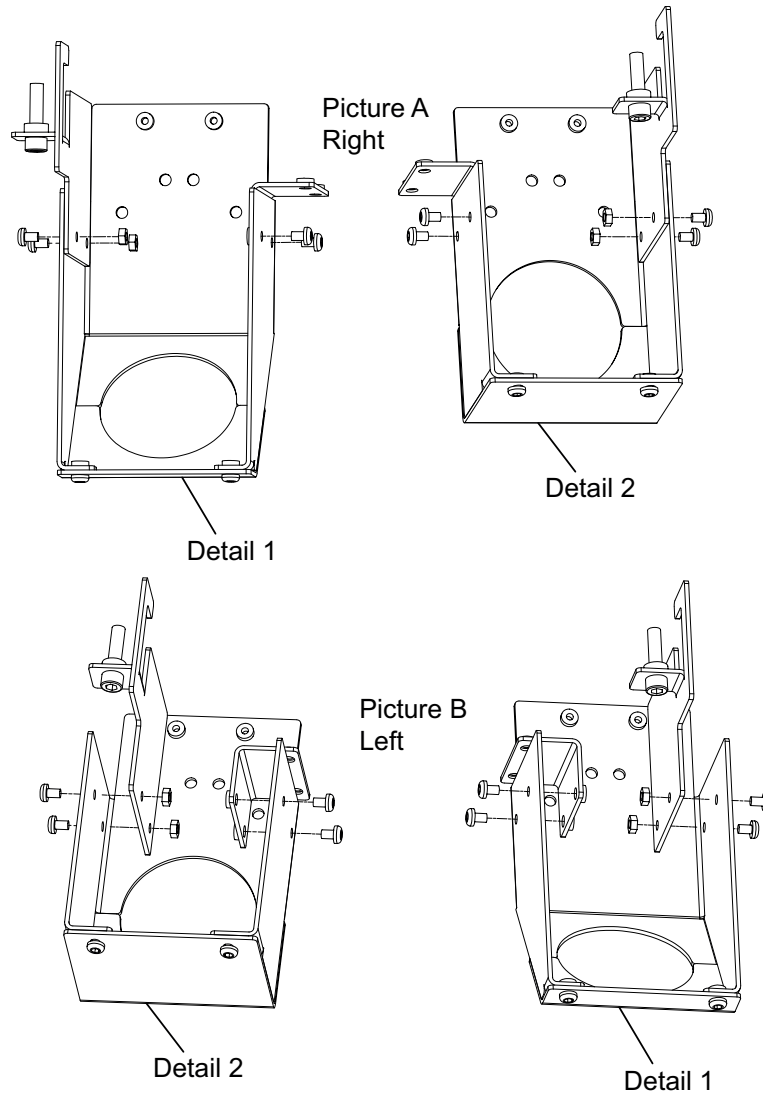

Fig. 4-20 Cable channel hose frames

# Installation

## Mechanical Installation of OTC

---

Install the cable channel, see the figure, and tighten the screws (1) to lock the cable channel.

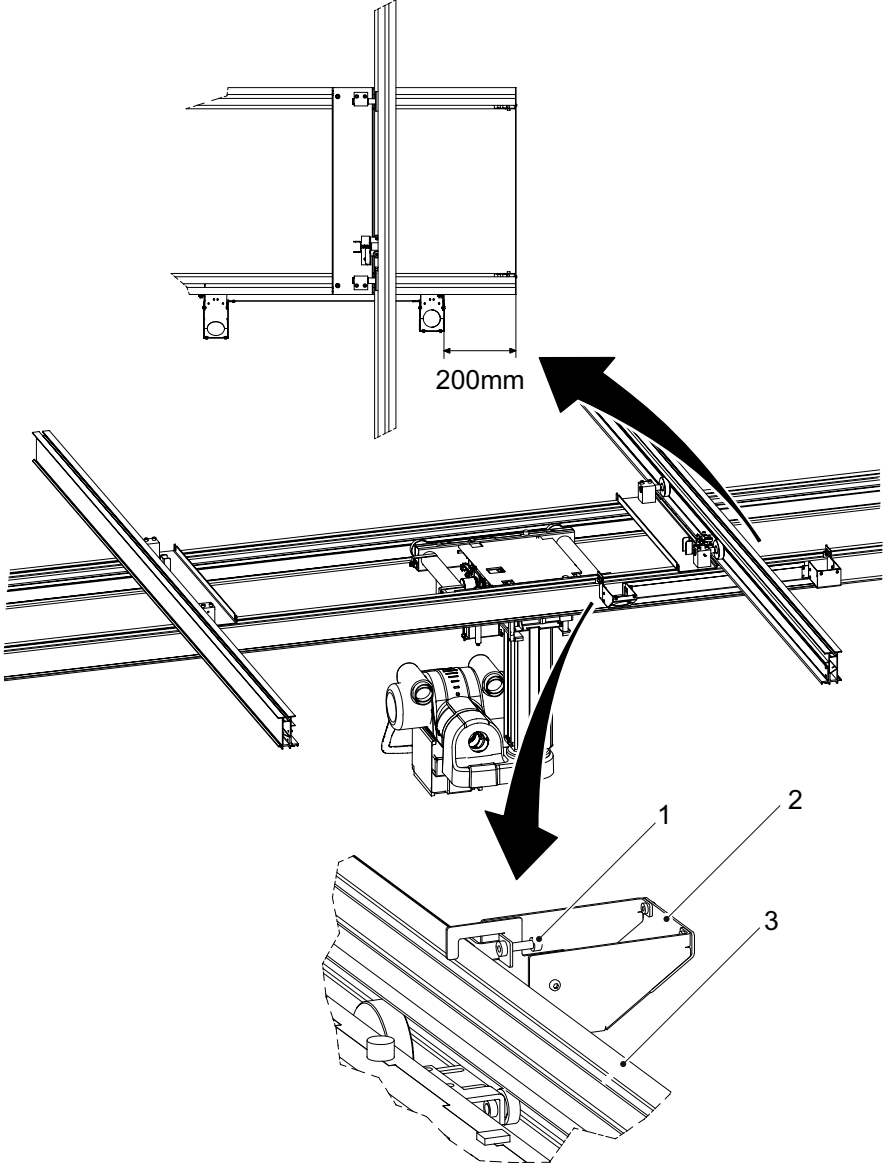

Fig. 4-21 Installing cable channel

- 1. Screw
- 2. Cable channel
- 3. Traverse rail X

### 4.7.8 Connect Brake Y

Connect the cables to the brakes Y according to figure below. For more information see Chapter Electrical drawings. Bundle remaining cable length and place it on top of the distance plates.

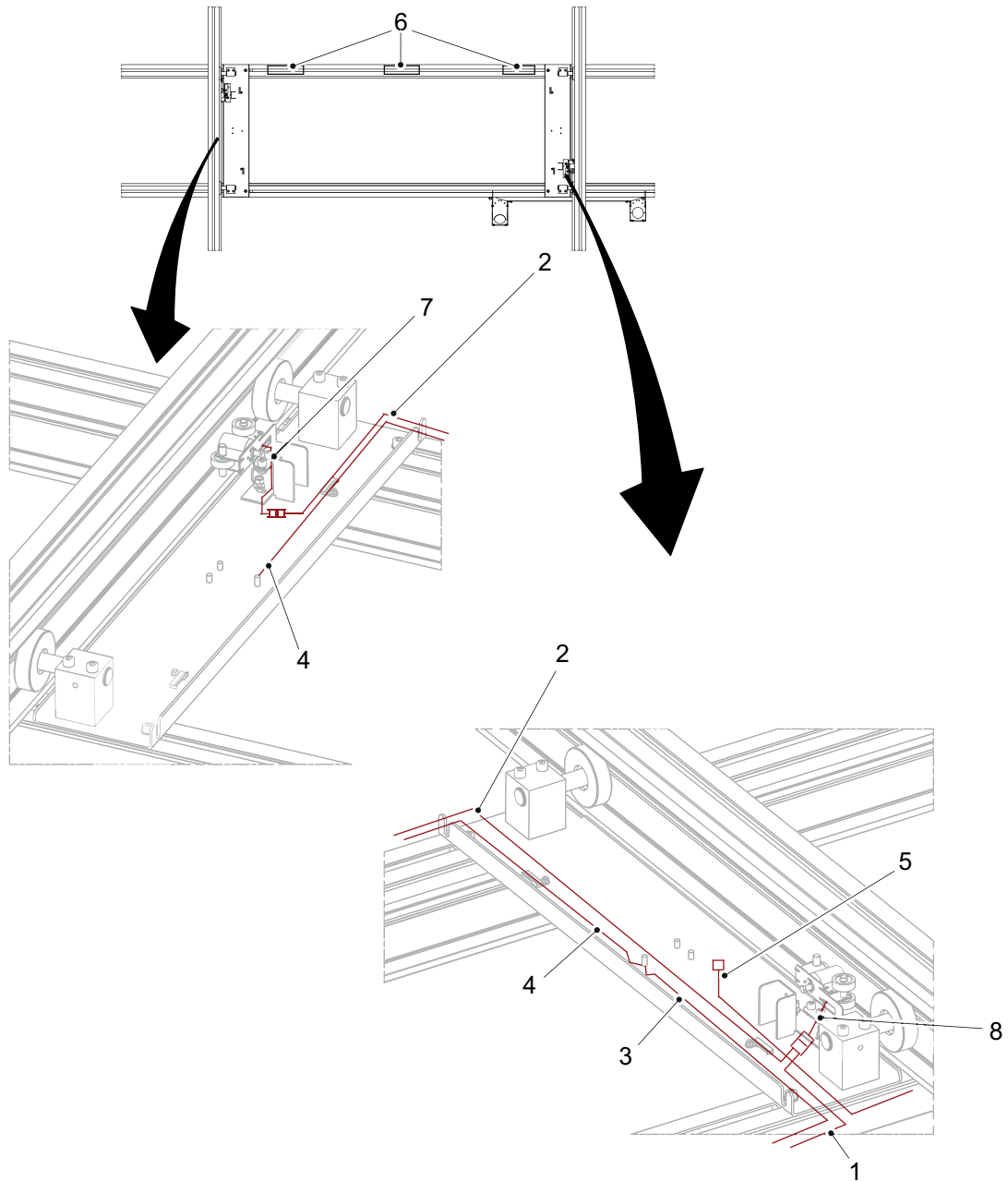

Fig. 4-22 Connecting cables to Y-brakes

- |             |                                  |
|-------------|----------------------------------|
| 1. 1,4BRA01 | 5. 1,4SIG01 (option fail safe Y) |
| 2. 1,4BRA02 | 6. Tape                          |
| 3. 1,4PE01  | 7. 1,4 J03                       |
| 4. 1,4PE02  | 8. 1,4 J02                       |

# Installation

## Mechanical Installation of OTC

---

To change the cable channel from right to left side, loosen the four screws according to picture C in Fig. 4-23 *Cable channels*.

Loosen the screws according to picture A in Fig. 4-20 *Cable channel hose frames* and switch place on the hose frames (detail 1 and 2).

Tighten the screws according to picture B in Fig. 4-20 *Cable channel hose frames* and D in Fig. 4-23 *Cable channels*. The cable channel can now be installed on the left side of the ceiling wagon.

Insert the cables inside the cable channel.

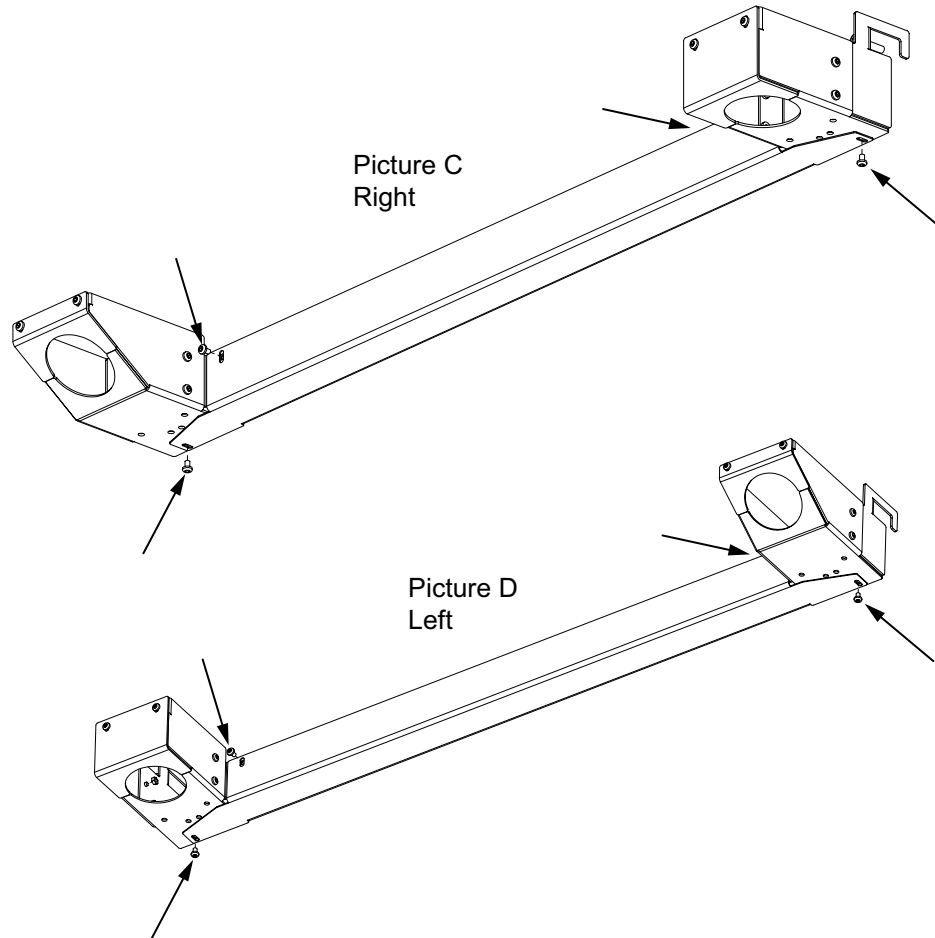

Fig. 4-23 *Cable channels*

### 4.7.9 Wall Attachment

Move the traverse rail X to its end position so the cable channel, installed on the traverse rail X, shall point toward the middle of the ceiling rail Y, according to figure below. If the OTC is not moved to its end position the hose may not be long enough when the OTC is positioning after installation.

Measure the distance A and install the wall attachment on half this distance (distance B) and at the same height as the ceiling rails Y. Use screws (M8x16), for locking the cable holder in- to the traverse. Shorten the hose if necessary after installing the wall attachment.

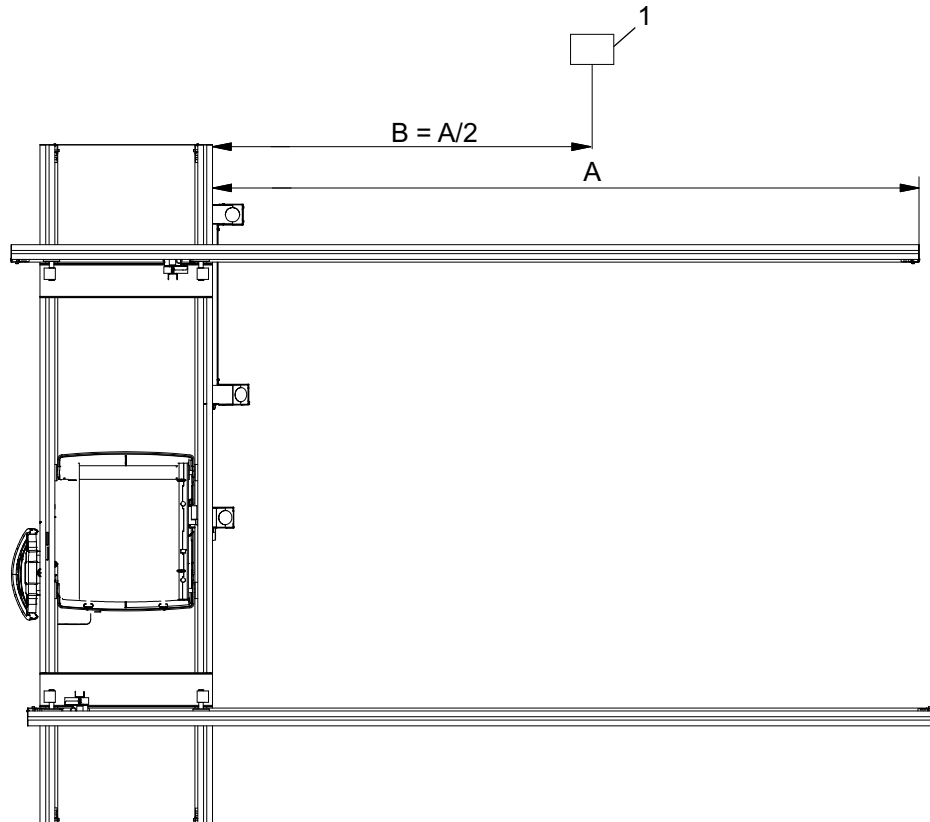

Fig. 4-24 Installing wall attachment

1. Wall attachment

# Installation

## Mechanical Installation of Cabinet

### 4.8 Mechanical Installation of Cabinet

Place the cabinet in a corner of the room.

See the Planning Guide for further instruction of location in the room.

#### 4.8.1 Cover for Cable Outlet

The corner marked (1) in figure below must be placed in one corner of the room. Depending on the installation of the cables from the OTC, Table and Wallstand, one of the cable outlets (2) is used.

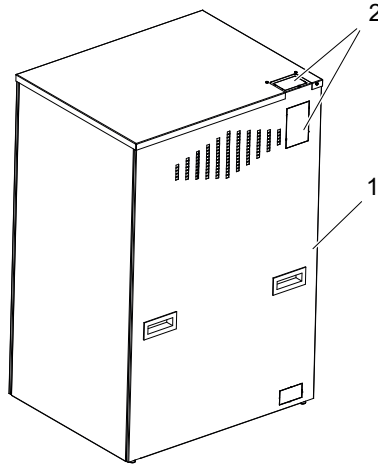

Fig. 4-25 Cable outlets

- Remove one of the covers to the cable outlets (2).
- The borders of the outlet have to be covered with the enclosed edging strip.

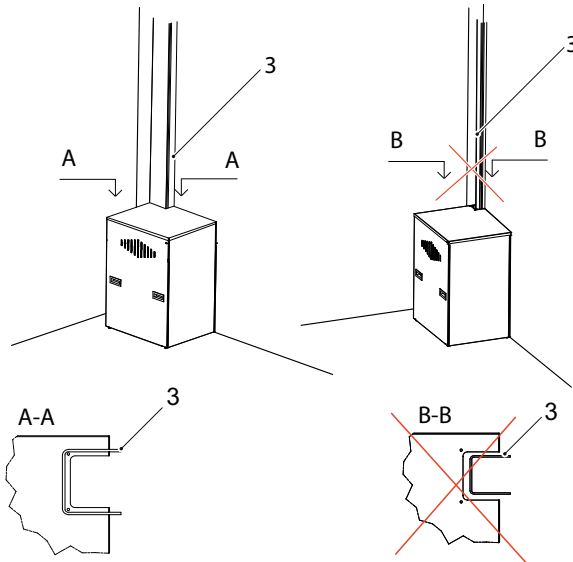
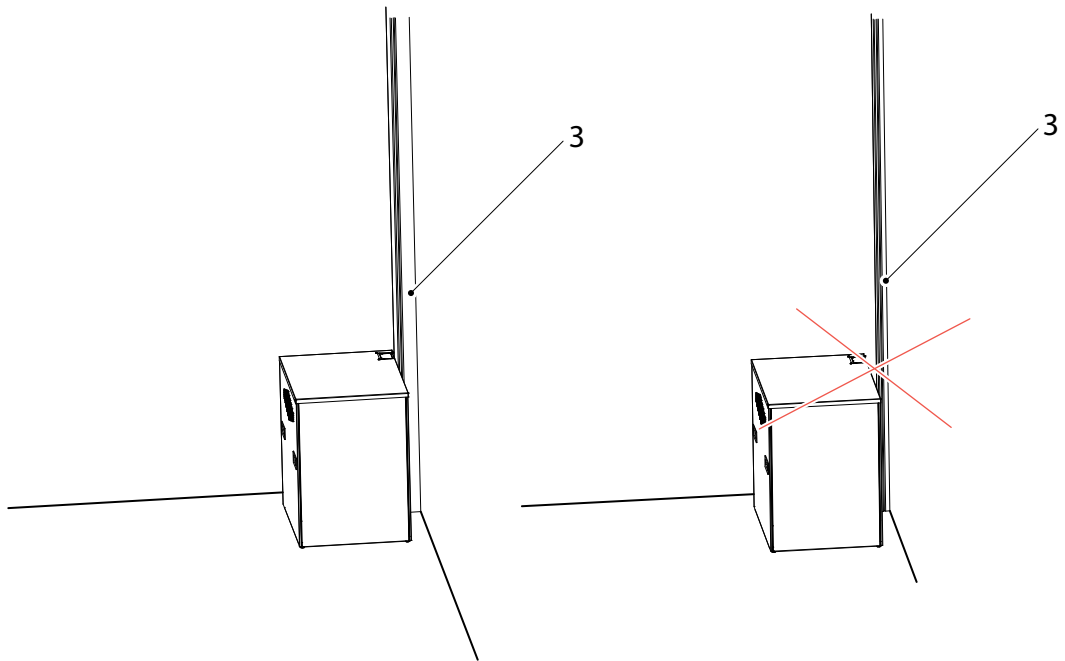

Fig. 4-26 Positioning cabinet

- The cables must be covered with a cable channel. The cable channel has to cover the cable outlet completely see section A-A up of and figure below. The cable channel should only be possible to open with a tool.
- The cables have to be secured with a cable clamp or a suitable strain relief.





*Fig. 4-27 Covered cables*

# Installation

## Mechanical Installation of Cabinet

---

### 4.8.2 Remove Covers, Cabinet

Open the top cover of the cabinet, by removing the two screws (one at each side). Raise the top cover and then fasten the cover in the raised position by fastening the screws in the new position. This will considerably improve the workspace.

Remove the front, right and back cabinet covers according to figure below, in the order that fits best.

Preferably the left cover (seen from the front) can stay mounted.

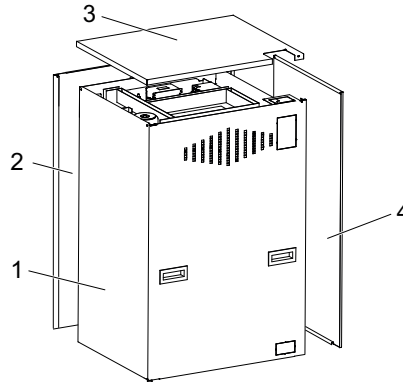

*Fig. 4-28 Remove cabinet covers*

Remove the following components from the system cabinet;

- |                          |  |
|--------------------------|--|
| 1 pc Cable CPI 732091-00 | Control cable from generator to mini console.        |
| 1 pc Cable 90178000F     | RS 232 cable from generator to Image system computer |
| 1 pc Mini console        | On/Off and exposure for generator/System             |

### 4.9 General



#### **WARNING!**

---

*To avoid risk of electric shock, this equipment must only be connected to a supply mains with protective earth.*

---



#### **WARNING!**

---

*All components shall be connected to the same earth connector on the System.*

---

#### **Note!**

---

*A disconnecting device from the mains shall be incorporated external to the equipment according to the national wiring rules.*

---

#### **4.9.1 Interfacing**

to the following standards and local regulations.

- IEC 60601-1
- IEC 60601-1-2
- IEC 60601-2-54
- MDD 93/42/EEC

# Installation

## Cable Paths

---

### 4.10 Cable Paths

The cable paths shall be as shown in Fig. 4-29 *Cable paths*.

**CAUTION!**

**It is important to tie the cables carefully to the frame. Otherwise there is a cable squeezing hazard.**

---

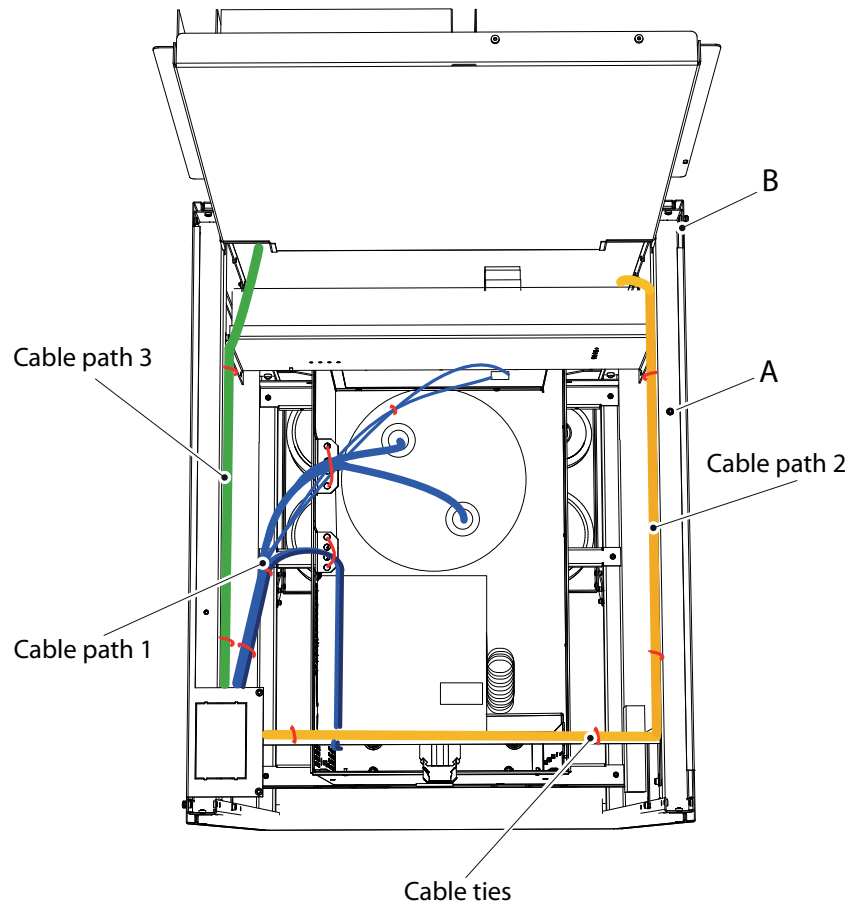

*Fig. 4-29 Cable paths*

1. Cable path number 1 — to the generator.
2. Cable path number 2 — to the electrical plate 4.2.
3. Cable path number 3 — to the electrical plate 4.4.

### 4.11 Electrical Installation of OTC

**Note!**

The installation cables from the OTC must be installed covered. They shall not be placed on the floor.

Lubricate the HSP connectors generously with silicone oil. Use the silicone gaskets.

Wiring to Generator, is made according to path 1, Fig. 4-29 Cable paths.

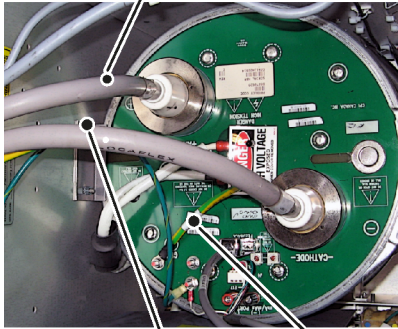
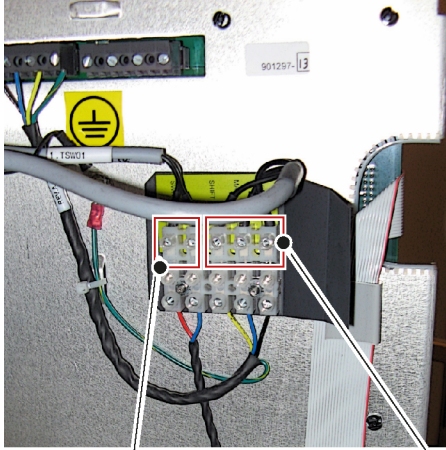
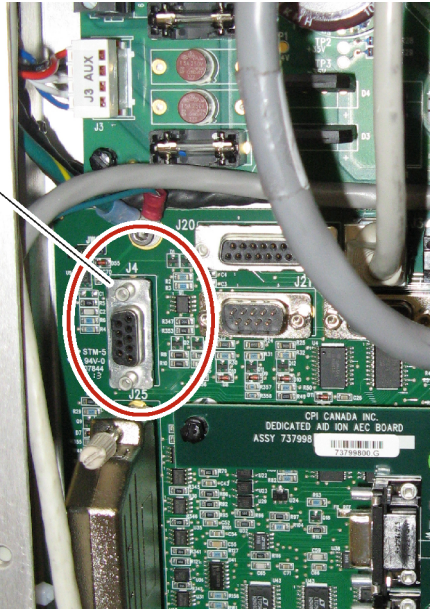
	
	<ol style="list-style-type: none"> <li>1. 1.THSP+</li> <li>2. 1.THSP-</li> <li>3. 1.TSTA01 — Rotation cable Cable 1 — Shift Cable 2 — Main Cable 3 — Common Shield — Ground</li> <li>4. 1.TSW01 — Cable 1 — Thermal switch — Cable 2 — Thermal switch</li> <li>5. 1.TPE01 — PE Tube</li> <li>6. 1.CDAP01 — GEN — J4</li> </ol>

# Installation

## Electrical Installation of OTC

---

Wiring to electrical plate 4.2 is made in accordance with cable path 2, Fig. 4-29 *Cable paths*.



Fig. 4-30 Electrical plate 4.2

1. 1.3PE01

2. 1.1POW01

# Installation

## Electrical Installation of OTC

Wiring to electrical plate 4.4 is made in accordance with cable path 3, see Fig. 4-29 *Cable paths*.

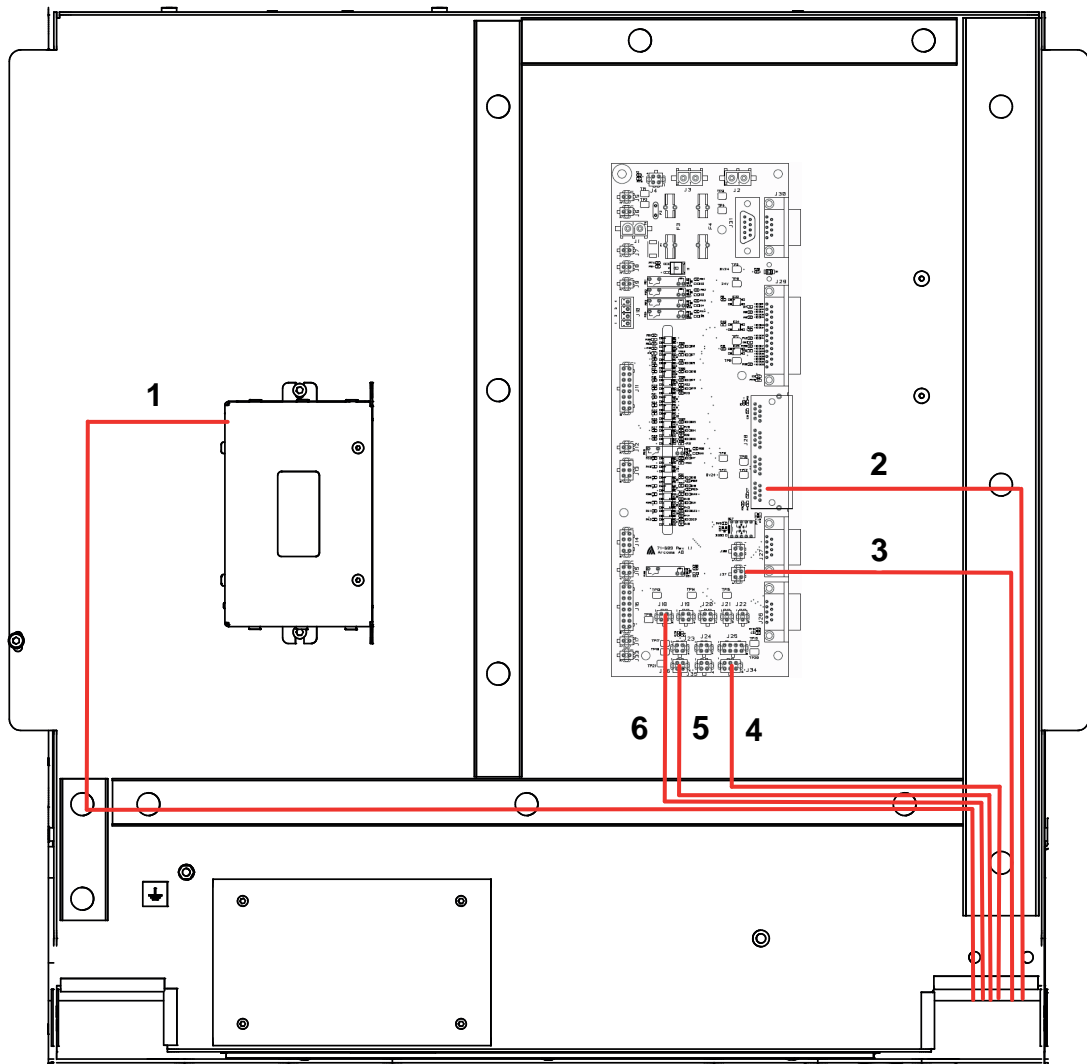

Fig. 4-31 Electrical plate 4.4

1. 1.1DSP01	4.4CB800_01-J0
2. 1.1CAN02	4.4FIB01 J28-P1
3. 1.1SIG01	4.4FIB01-J37
4. 1.1FS01	4.4FIB01-J34
5. 1.4SIG01	4.4FIB01-J36
6. 1.1EM01	4.4FIB01-J18

# Installation

## Electrical Installation of OTC

### 4.11.1 External Exposure Switch

There is an option to connect an external exposure switch at J20, see Fig. 4-32

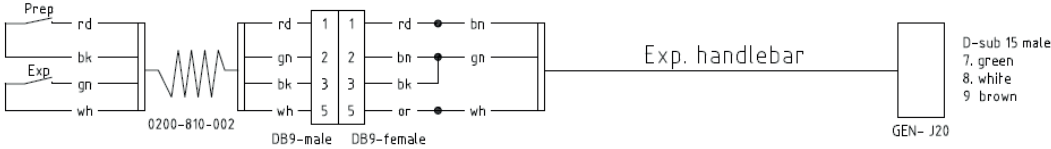

Fig. 4-32



### 4.12 Install Imaging System

Below is the configuration upon delivery.

**Note!**—

---

*It is up to the installer to customize the configuration for the customer needs.*

---

There are 6 receptors (to the 3 power boxes).

The green indication light on the Table will activate on selection of a Table APR.

The green indication light on the Wallstand will activate on selection of a Wallstand APR.

**1. Receptor 1**

- is used for a fixed detector in the Table,
- or a portable detector placed in the Table detector holder.

AEC will be ON.

This receptor shall be used for all APR's where the detector is to be placed in the detector holder of the Table.

**2. Receptor 2**

- is used for a portable detector **on** the Table top.

AEC will be OFF.

This receptor is used for all APR's where the detector shall be placed **on** the Table top, or nearby the Table.

It is important to setup the receptor symbols on the Canon side so it matches the intended examination.

If the 801–detector is connected to the “first Canon power box”, the one in the control room, the receptor 2 may be used for the 801.

**3. Receptor 3**

- is used for a fixed detector in the Wallstand
- or a portable detector placed in the Wallstand detector holder.

AEC will be ON.

This receptor shall be used for all APR's where the detector is to be placed in the detector holder of the Wallstand.

**4. Receptor 4**

- is used for a portable detector, related to the Wallstand.

AEC will be OFF.

**5. Receptor 5**

- is used when using a third Canon power box connected to a portable detector, free in the room.

# Installation

## Electrical Installation of CPI Mini Console

### 4.13 Electrical Installation of CPI Mini Console

Position the Mini console in the operation room and connect cable CPI 732 091-00 between the mini console and the cabinet.

Connect the Canon cable 90178000F between the generator and the Image system computer.

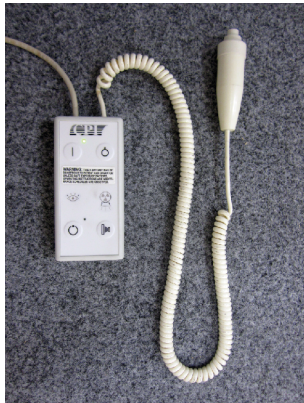

Connecting Mini Console



Cable 732 091-00 is hanging, rolled together, inside the cabinet.

Wiring shall be made according to path 1.

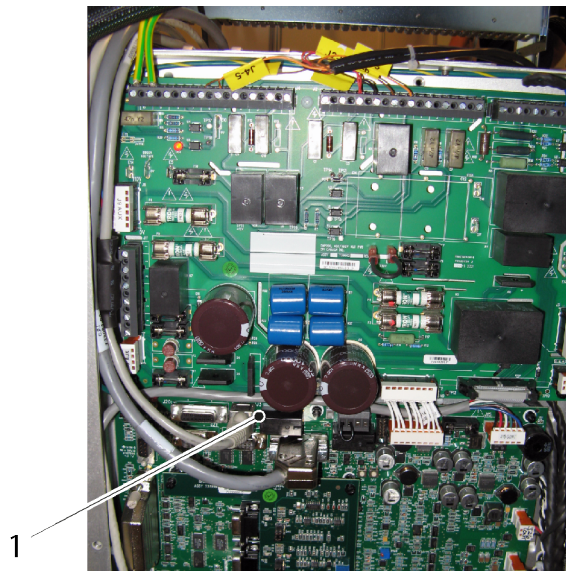

Fig. 4-33 Connecting CPI mini console

1. Cable 90178000F — J3

### 4.14 Wireless Detector

When using a wireless detector in Wallstand or Table, an X-ray interface box for the detectors, is assembled inside the Cabinet. For location, see Fig. 4-34 *X-ray interface box*

X-Ray interface box

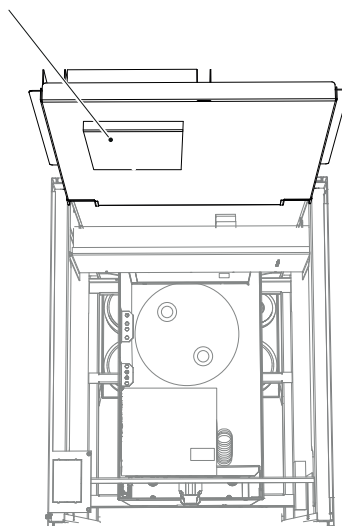

*Fig. 4-34 X-ray interface box*

# Installation

## Electrical Building Installation

### 4.15 Electrical Building Installation

The Machinery Directive 2006/42/EC requires the System to be fitted with means to isolate it from all energy sources.

*Note!*

*When Service or Maintenance will be performed, the technician shall lock the equipment from all energy sources.*

*Note!*

*A disconnecting device from the mains shall be incorporated external to the equipment according to the national wiring rules.*

- 3 Phase VAC +/- 10%
- 400 VAC 50 Hz
- 400 VAC with neutral 50 Hz
- 480 VAC 60 Hz
- Maximum wire gauge 4 AWG (25 mm<sup>2</sup>)
- Required fuse 63A, 3-phase, b-curve

<b>Generator Series and Mains Voltage</b>	<b>Minimum Recommended Mains Disconnect to Generator (15 ft/5 m maximum)</b>	<b>Generator Momentary Line Current</b>	<b>Minimum Recommended Generator Service Rating</b>	<b>Minimum Recommended Distribution Transformer Rating</b>	<b>Minimum Recommended Ground Wire Size</b>	<b>Apparent Mains Resistance</b>
<b>50kW 400 VAC, 3p.</b>	(13.3 mm <sup>2</sup> )	100 A	100 A	65 kVa	(13.3 mm <sup>2</sup> )	0.17 Ω
<b>65kW 400 VAC, 3p.</b>	(13.3 mm <sup>2</sup> )	125 A	100 A	85 kVa	(13.3 mm <sup>2</sup> )	0.13 Ω
<b>80kW 400 VAC, 3p.</b>	(13.3 mm <sup>2</sup> )	155 A	100 A	105 kVa	(13.3 mm <sup>2</sup> )	0.10 Ω
<b>50 kW480 VAC, 3p.</b>	(13.3 mm <sup>2</sup> )	80 A	100 A	65 kVa	(13.3 mm <sup>2</sup> )	0.24 Ω
<b>65 kW480 VAC, 3p</b>	(13.3 mm <sup>2</sup> )	105 A	100 A	85 kVa	(13.3 mm <sup>2</sup> )	0.19 Ω
<b>80 kW480 VAC, 3p</b>	(13.3 mm <sup>2</sup> )	130A	100 A	105 kVa	(13.3 mm <sup>2</sup> )	0.15 Ω

Recommended Service Disconnect (as per the above table):

- All wiring and grounding should comply with the national electrical code or equivalent.
- All wiring must be copper.
- The disconnecting switch shall be located within reach of the operator.

### 4.15.1 400VAC

Having selected the voltage, make a mark at the system serial number label, at the related check box for the power rating.

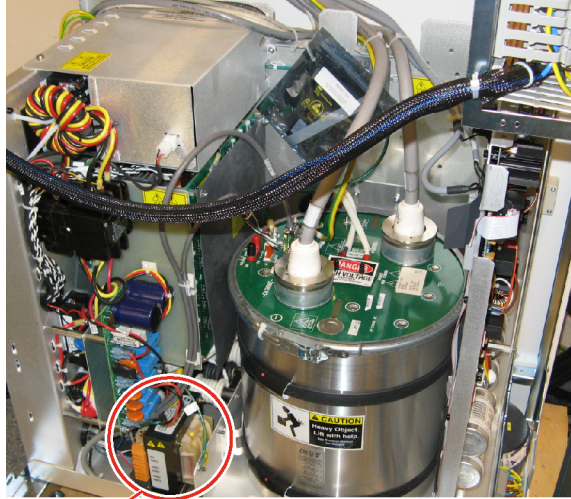

1

Fig. 4-35 400VAC

1. Position of generator transformer.

Check that the red wire is connected to 400V, at the generator transformer. See Fig. 4-36 *Connection 400V*

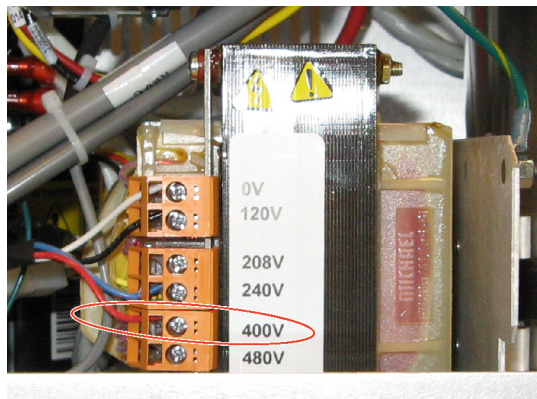

Fig. 4-36 Connection 400V

# Installation

## Electrical Building Installation

When changing voltage, set the DIP switch SW3-8 according to the mains voltage. See Fig. 4-37 400V, DIP switch SW3-8

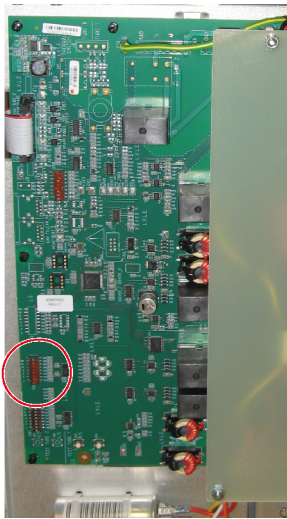
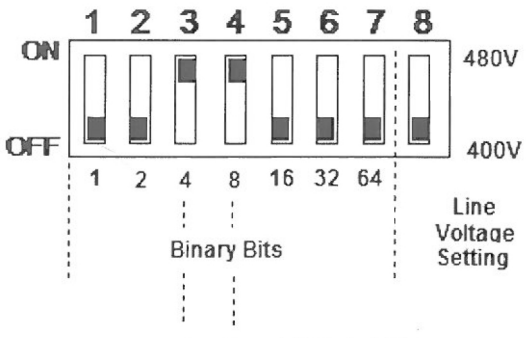
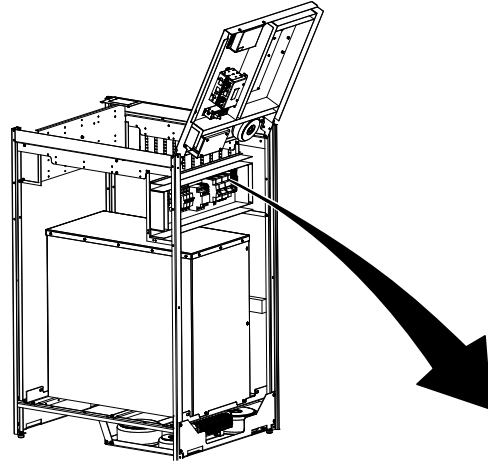
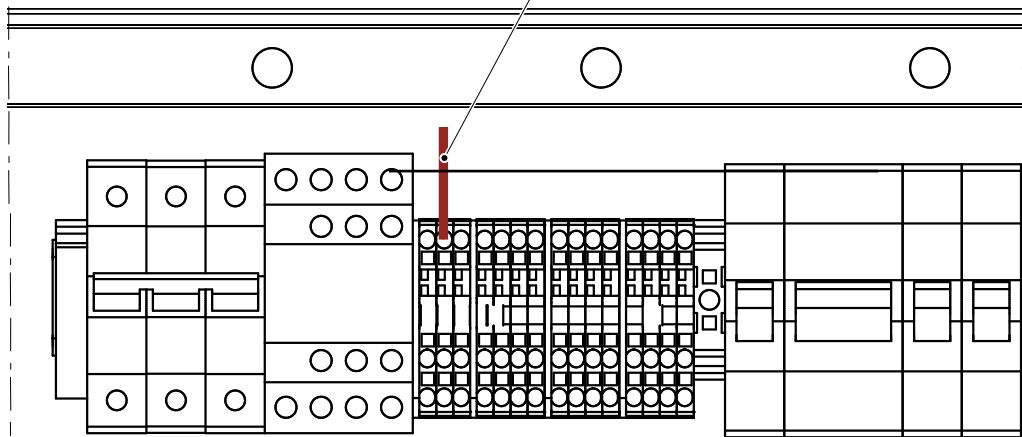

Fig. 4-37 400V, DIP switch SW3-8

Make sure the wire (A) is connected according to Fig. 4-38 .



**A 4.2J01-1**



*Fig. 4-38*

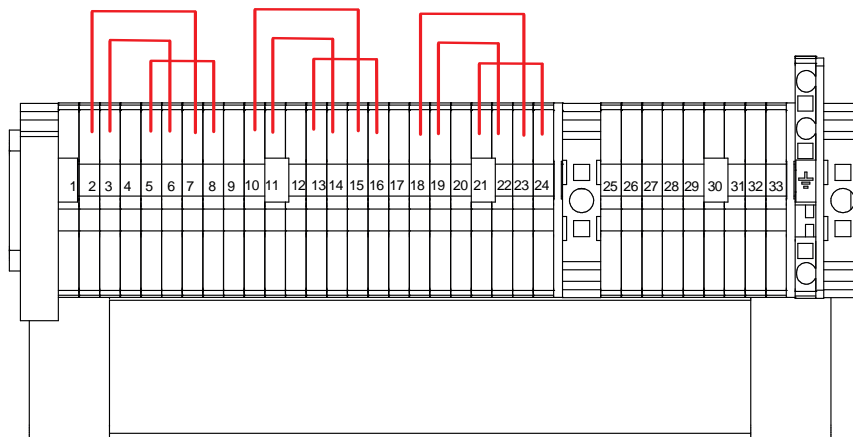

*Fig. 4-39 380V*

# Installation

## Electrical Building Installation

---

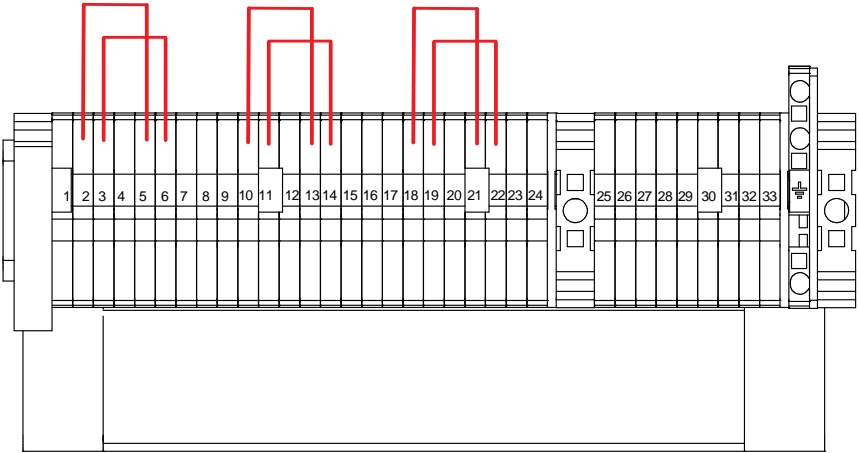

Fig. 4-40 390V

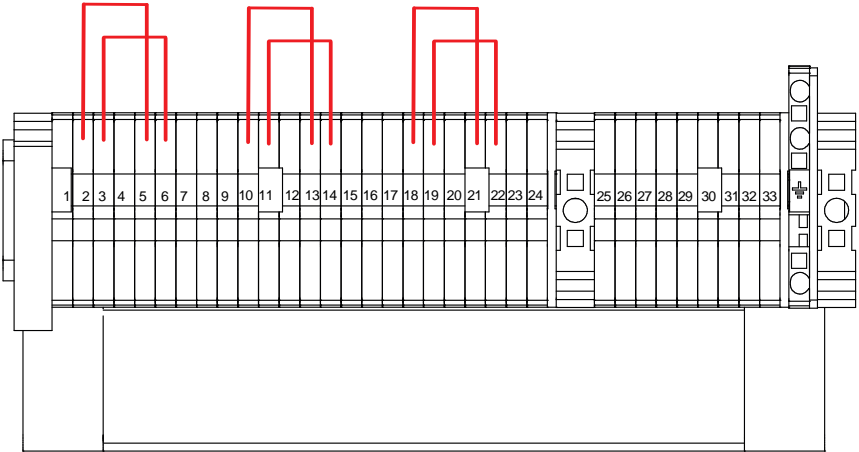

Fig. 4-41 390V

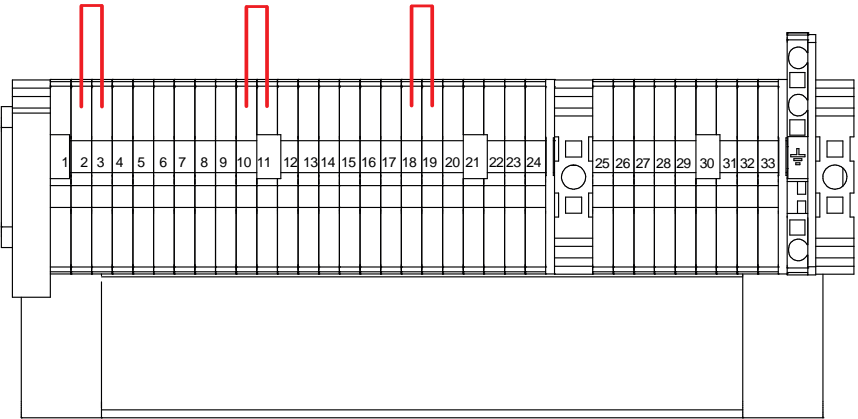
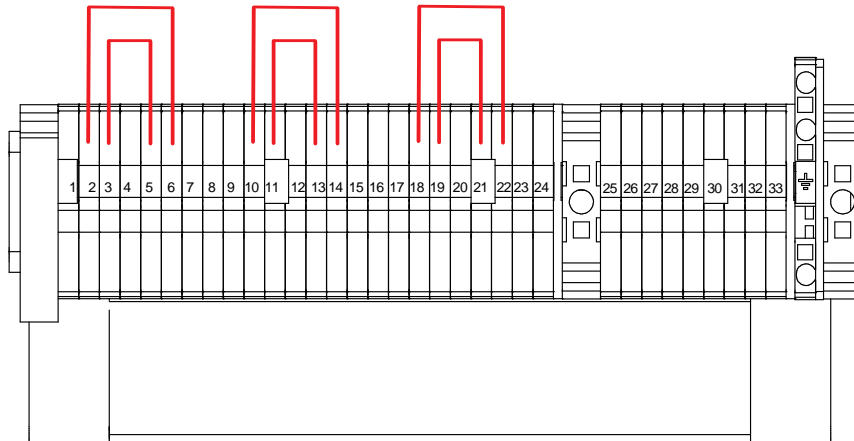
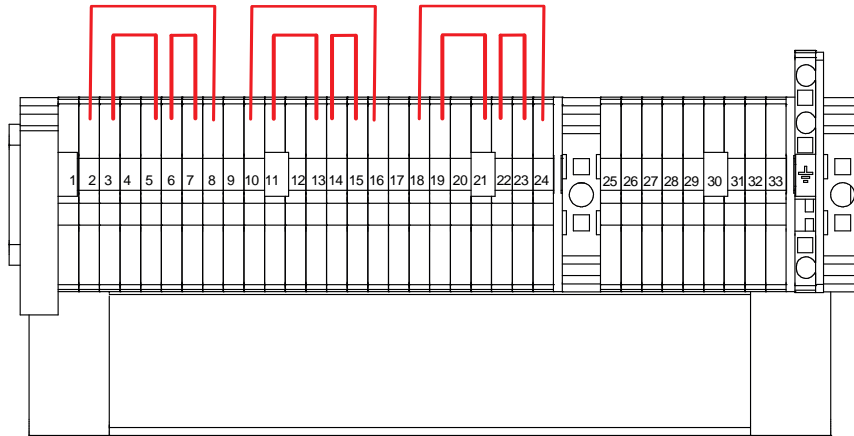

Fig. 4-42 400V





*Fig. 4-43 410V*



*Fig. 4-44 420V*

# Installation

## Electrical Building Installation

---

### 4.15.2 480VAC

Having selected the voltage, make a mark at the system serial number label, at the related check box for the power rating.

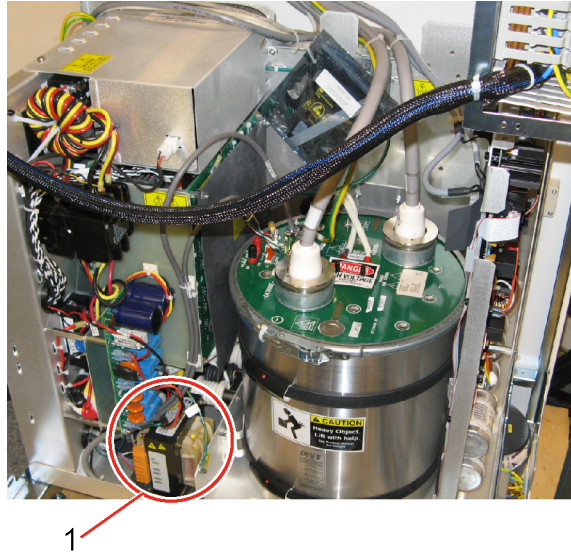

Fig. 4-45 480VAC

1. Position of generator transformer.

Check that the red wire is connected to 480 V, at the generator transformer. See Fig. 4-46 *480V connection*

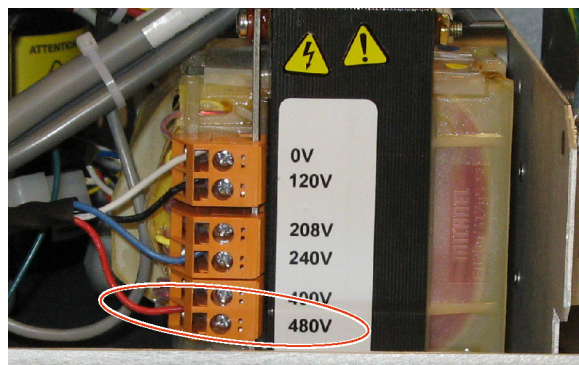

Fig. 4-46 480V connection

# Installation

## Electrical Building Installation

When changing voltage, set the DIP switch SW3-8 according to the mains voltage. See Fig. 4-47 480V, DIP switch SW3-8

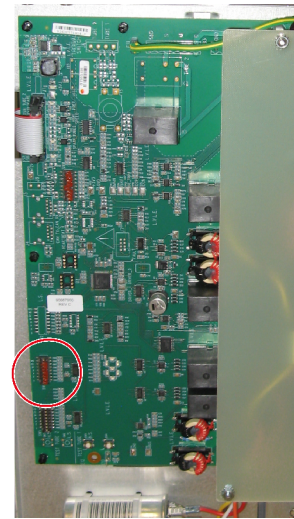
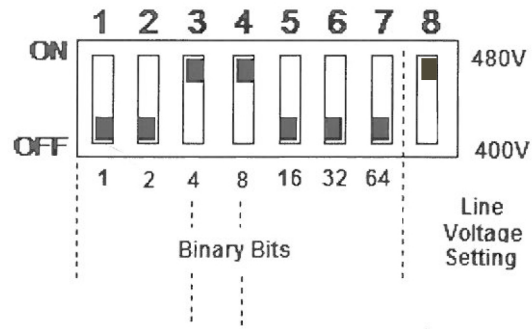

Fig. 4-47 480V, DIP switch SW3-8

# Installation

## Electrical Building Installation

Make sure the wire (A) is connected according to figure.

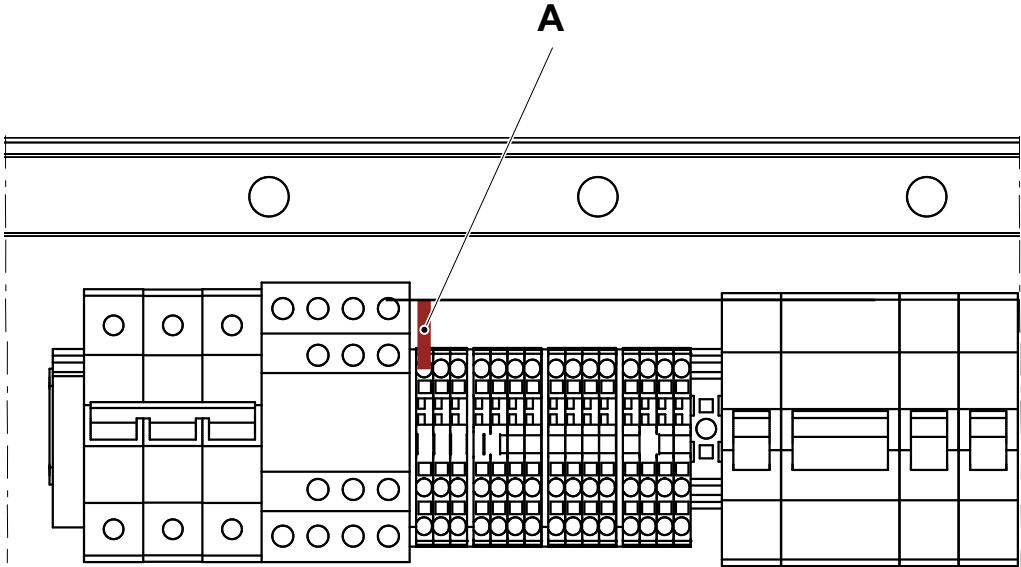
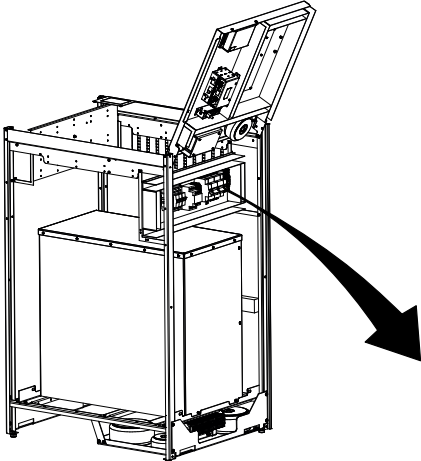

Fig. 4-48

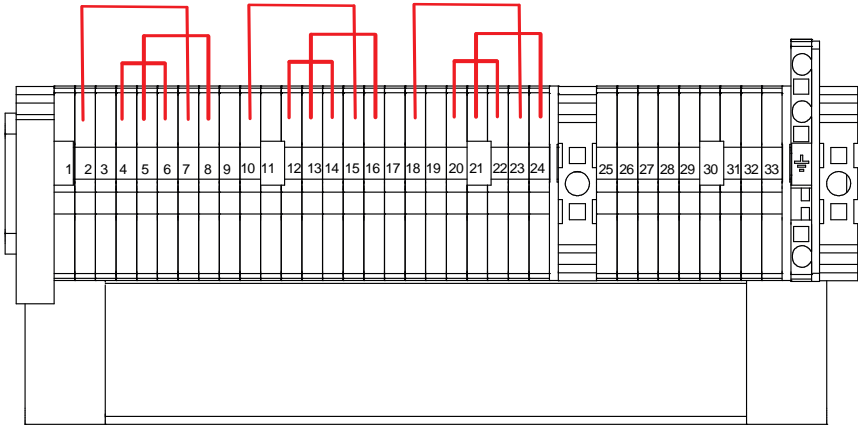

Fig. 4-49 460V

# Installation

## Electrical Building Installation

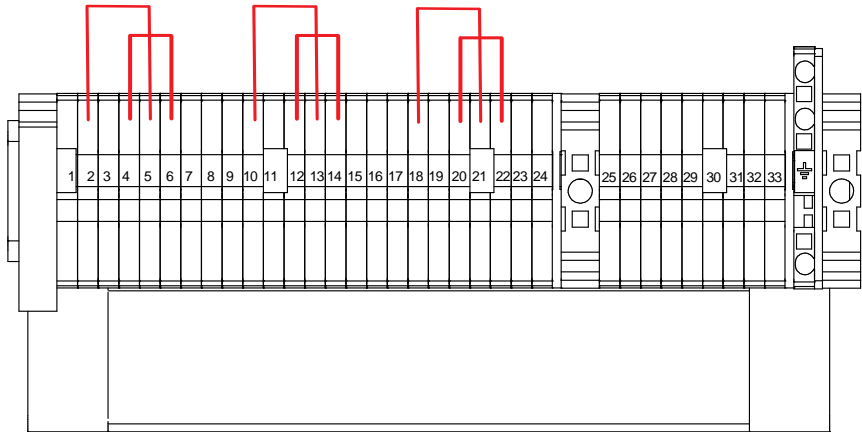

Fig. 4-50 470V

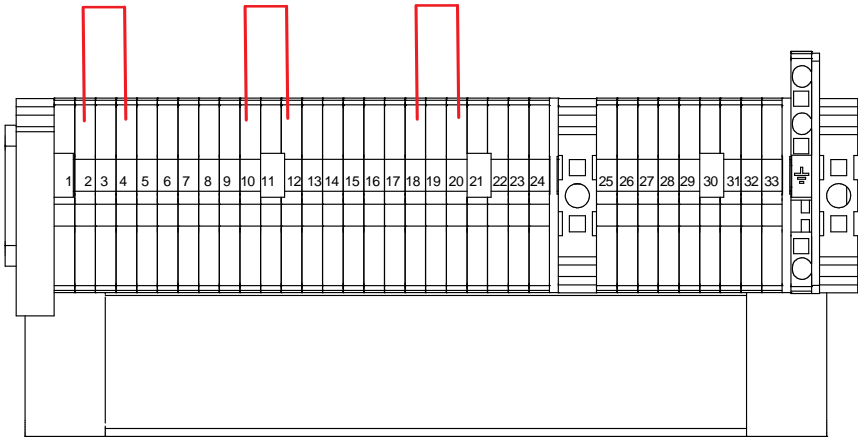

Fig. 4-51 480V

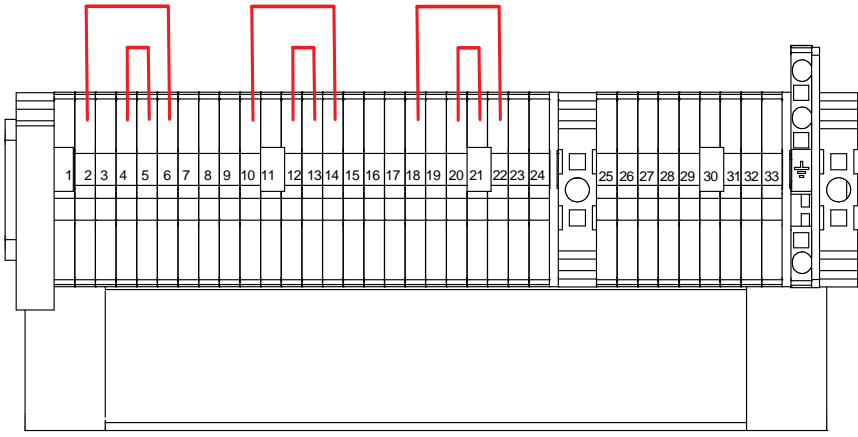

Fig. 4-52 490V

# Installation

## Electrical Building Installation

---

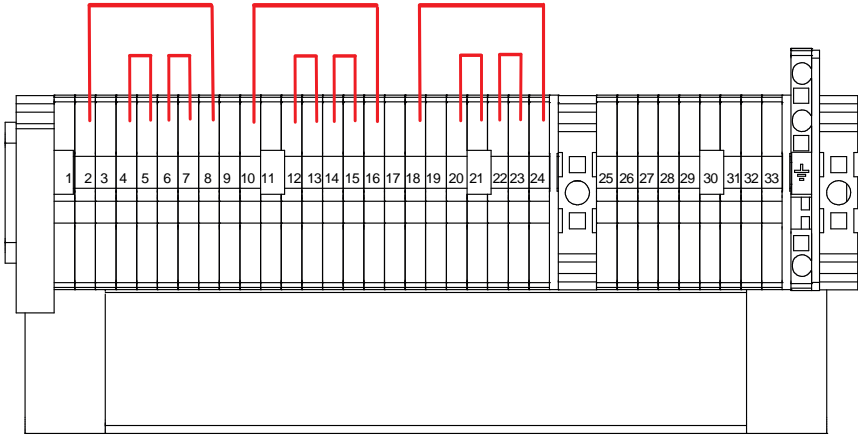

Fig. 4-53 500V

### 4.15.3 Mains

Connect mains power and mains protective earth according to Fig. 4-54 *Connecting mains power and mains protective earth*.

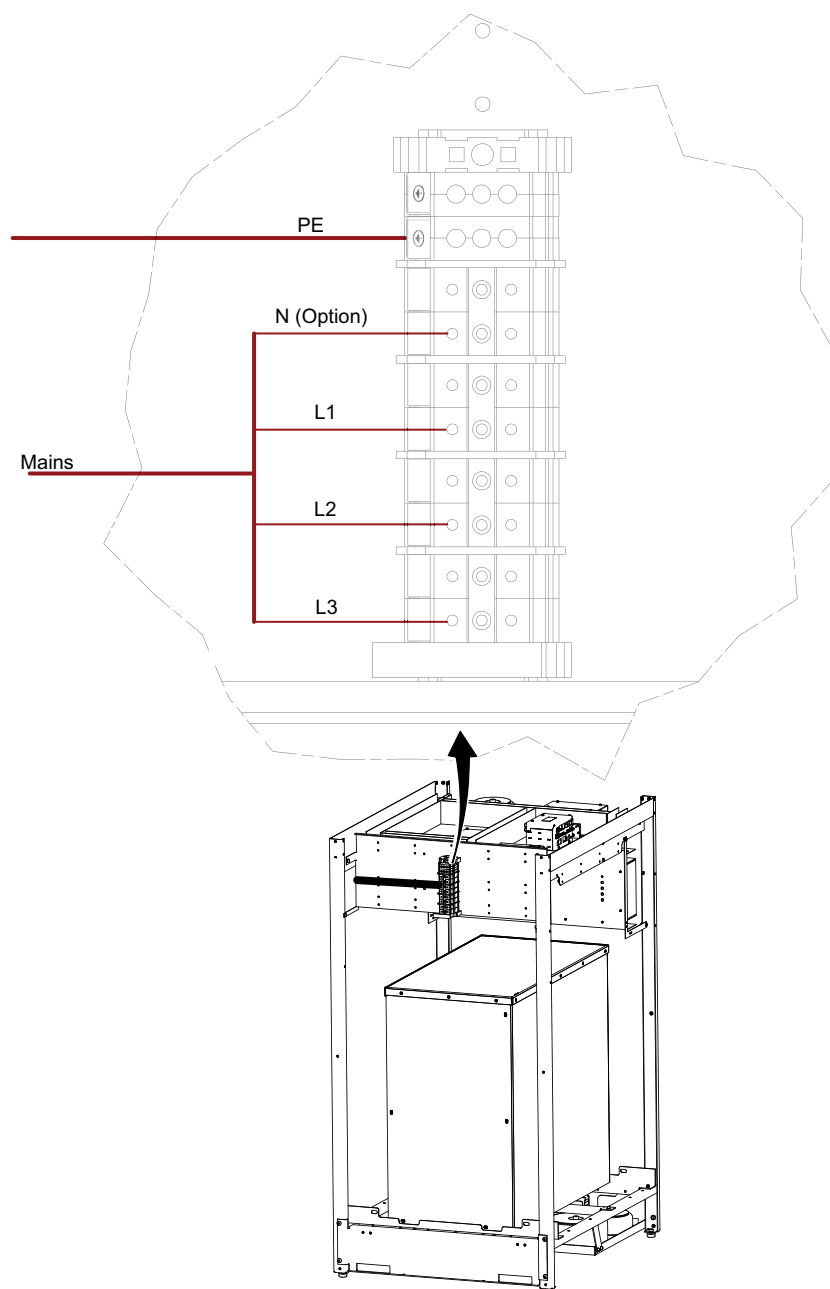

Fig. 4-54 Connecting mains power and mains protective earth

# Installation

## Start-up Procedure

### 4.16 Start-up Procedure

#### 4.16.1 Check Voltage of the Subsystem

Switch off (press down) the fuses according to picture 1 in Fig. 4-55 *Checking power of the subsystem*, and switch on the power to the System from the mains switch.

Measure at the fuse 4.2F02 and 4.2F05 according to picture 2 in Fig. 4-55 *Checking power of the subsystem*.

- $U1 = 230V \pm 10\%$
- $U4 = 230V \pm 10\%$

If the measured value fails to correspond with the levels listed above, check the tap configuration.

If the measured values correspond with the levels listed above, switch on (press up) 4.2F02.

Switch on the power to the system from the generator console "On" button according to picture 3 in figure.

Measure at the 4.2F03 and 4.2F04 according to picture 2.

- $U2 = 230V \pm 10\%$
- $U3 = 230V \pm 10\%$

If the measured values correspond with the levels listed above, switch off the power at generator console "Off" button (picture 3 in figure) and switch on (press up) 4.2F03, 4.2F04 and 4.2F05.

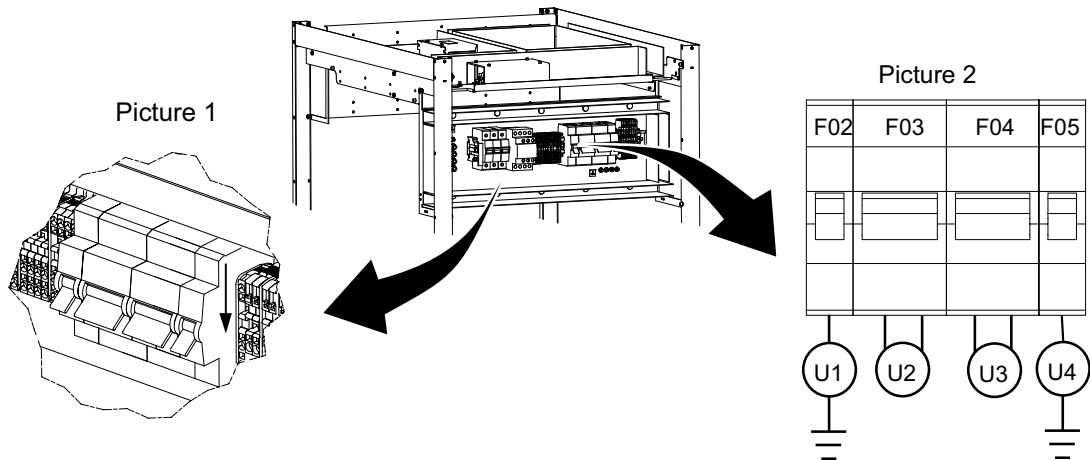
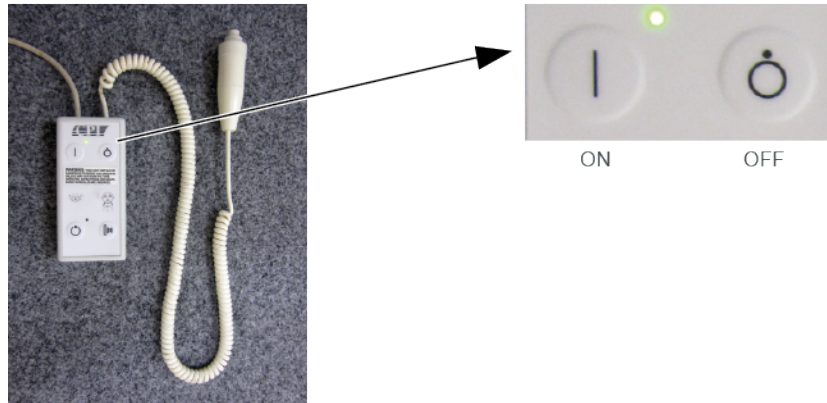

Fig. 4-55 *Checking power of the subsystem*



Picture 3



*Fig. 4-56 Power switch off*

# Installation

## Alignment of OTC

---

### 4.17 Alignment of OTC

1. Switch on the power to the System from the generator console.
2. Enter the display menu. Deactivate the Wallstand and/or the Table at the menu.
3. Place a spirit level on the column, see figure below, and check that the column is vertical ( $\pm 1^\circ$ ).
4. Place a spirit level on the OTC tube and check that the tube is horizontal ( $\pm 1^\circ$ ) in both directions.

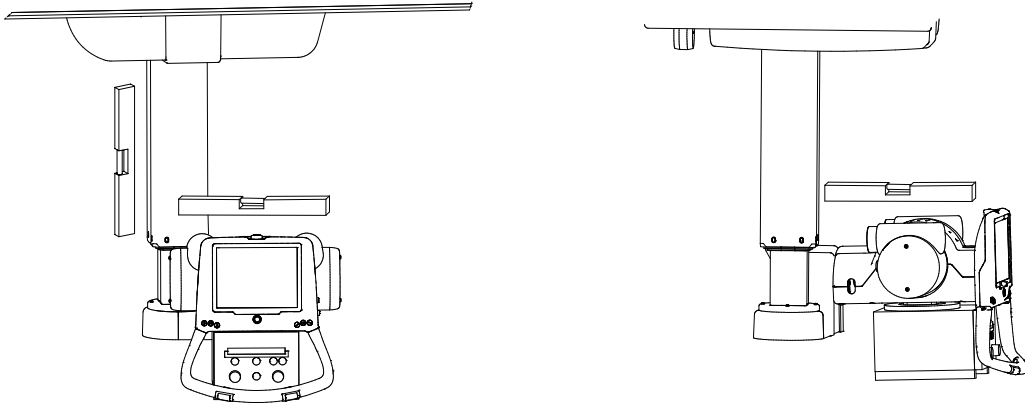

*Fig. 4-57 Checking alignment*

5. Turn on the collimator light and mark a cross in the center of the collimator light field on a piece of paper placed on the floor, according to the figure below.
6. Drive the column upward/downward and the center of the collimator light field must stay on the same mark on the paper.  
If the collimator light field moves in X or Y direction, check the ceiling rails Y and traverse rail X to verify that they are level.

### 4.17.1 Alignment of OTC, X- and Y-direction

1. Turn on the collimator light and mark a cross in the center of the collimator light field on a piece of paper placed on the wall according to Fig. 4-58 *OTC vertical alignment* below.
  2. Move the OTC backward/forward and the center of the collimator light field must stay on the same mark on the paper, see Fig. 4-59 *Paper marks* below.
- If the collimator light field moves in Z direction, check the ceiling rails Y, and the traverse rail X. They must be level.

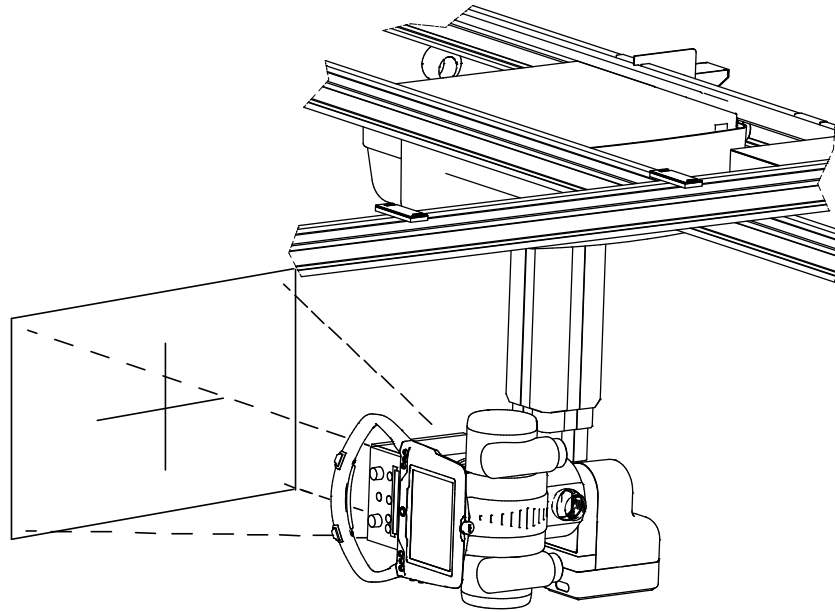

Fig. 4-58 OTC vertical alignment

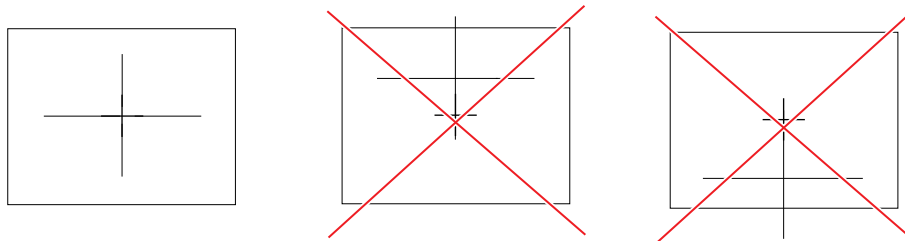

Fig. 4-59 Paper marks

# Installation

## Alignment of OTC

---

3. Turn on the collimator light and mark a cross in the center of the collimator light field on a piece of paper placed on the floor according to Fig. 4-60 *OTC horizontal alignment* below.
4. Drive the column upward/downward. The center of the collimator light field must stay on the same mark, see Fig. 4-61 *Paper marks* below.  
If the collimator light field moves in X or Y direction, check the ceiling rails Y and traverse rail X. They must be level.

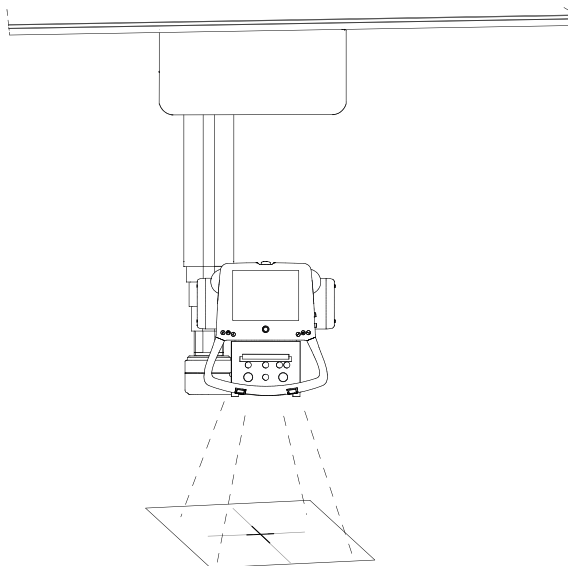

Fig. 4-60 OTC horizontal alignment

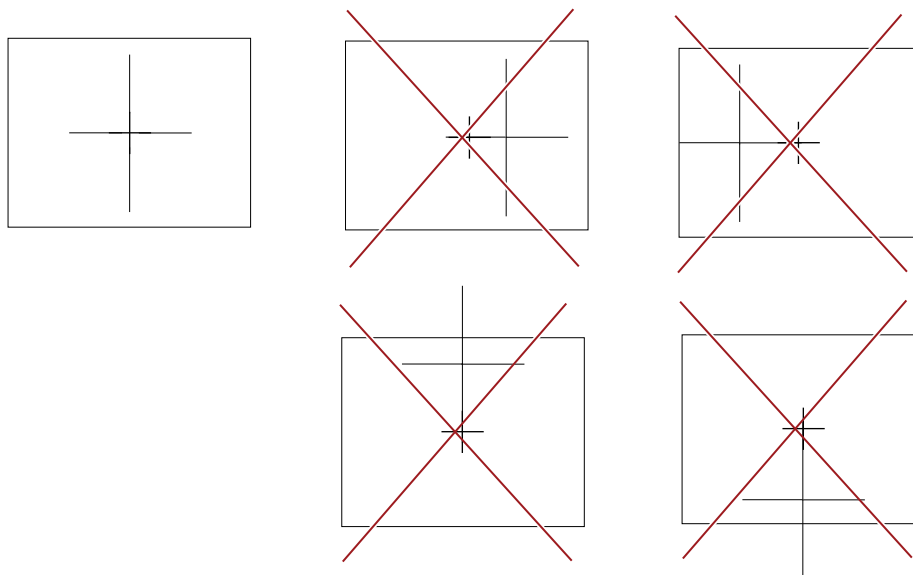

Fig. 4-61 Paper marks

5. Switch off the power to the System from the generator console.
6. Switch off the power to the System from the mains switch.

### 4.18 Mechanical Installation of Wallstand



#### **WARNING!**

---

*Whenever any item is removed from the Wallstand, e.g. the detector holder, the Wallstand will become highly unbalanced.*

*Whenever the brake is released, part of the Wallstand will move upward and can cause injury.*

*Make sure that the operation will be performed by personnel who are trained in the use of the equipment.*

---

#### 4.18.1 Orientation of Wallstand

Before unloading and placing the Wallstand on the floor, check for enough free space around the device to allow free movement. See the Planning Guide for further information of required space around the Wallstand and the position in the room.

#### 4.18.2 Unloading



#### **WARNING!**

---

*When the Wallstand is not bolted to the floor, the Wallstand is unstable and front-heavy and may fall down. When you get the Wallstand upright, make sure to bolt the Wallstand to the floor. Then, to balance the Wallstand, mount the counterweights.*

---

#### *Note!*

---

*Packages are marked with "Up" and "Down" on the top and bottom side of the wall stand, respectively.*

---

Follow the instruction for unloading the Wallstand.

1. Remove the package band from the package.
2. Remove all the mounting screws on the top and bottom of the crate sides.
3. Remove the top crate, then the crate sides as a set.
4. Remove the screws from two cross-ties, securing the Wallstand

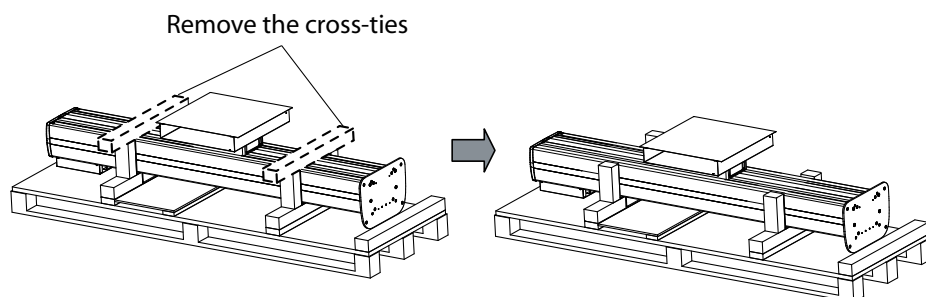

Fig. 4-62 Removing cross-ties

# Installation

## Mechanical Installation of Wallstand

**CAUTION!**  
**Do not hold the Wallstand by the base when lifting it up.**

**Note!**  
**Do not lift the Wallstand from the bottom.**

5. With help from at least two persons, lift the Wallstand, as indicated in the figure below. Lift the Wallstand off the pallet, see Fig. 4-63 *Lifting Wallstand off the pallet*.

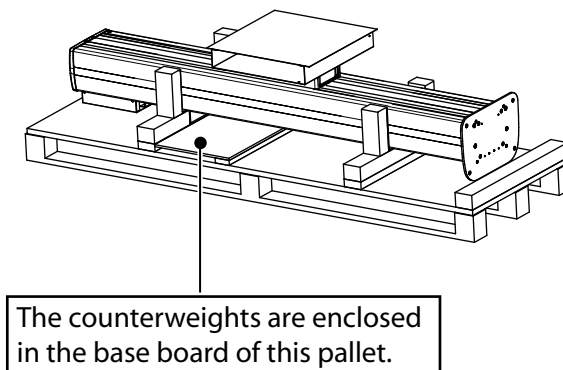

Fig. 4-63 *Lifting Wallstand off the pallet*

6. Position the Wallstand.
7. Mount the insulation washer (5) between the plate and the floor.
8. Temporarily attach the stand to the floor, with 1 bolt (1, 2, 3, 6) at the floor. Making it possible to readjust the parallelism to the Ceiling stand.
9. Drill just 1 hole (C) in accordance with Fig. 4-64 *Temporarily attachment*. The 3 remaining holes shall be drilled after the adjustment.

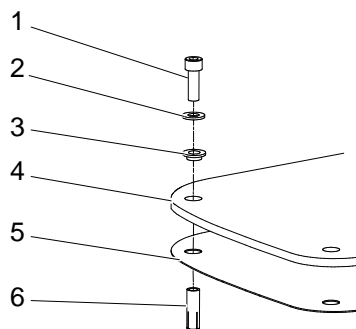

Fig. 4-64 *Temporarily attachment*

- |                      |                         |
|----------------------|-------------------------|
| 1. Bolt              | 4. Bottom plate         |
| 2. Insulation washer | 5. Insulation plate     |
| 3. Insulation case   | 6. Expanders (enclosed) |

### 4.18.3 Install CXDI-401G/401C Detector

If applicable, install the CXDI-401G/401C detector.

### 4.18.4 Remove Back Cover

1. Remove the two screws (hex-head screws, 3 mm diameter) under the electrical box.

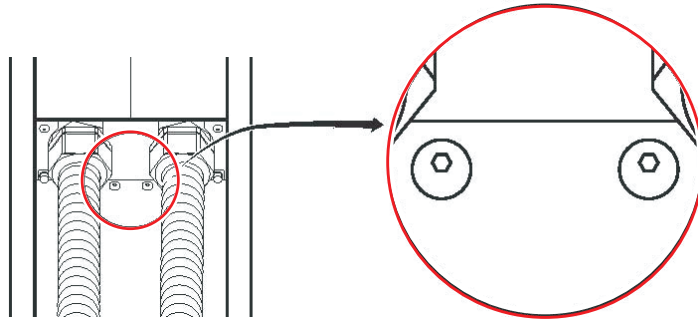

*Fig. 4-65 Removing the two screws under the electrical box*

2. Remove the two screws (hex-head screws, 2.5 mm diameter) at the bottom of the back of the Wallstand.

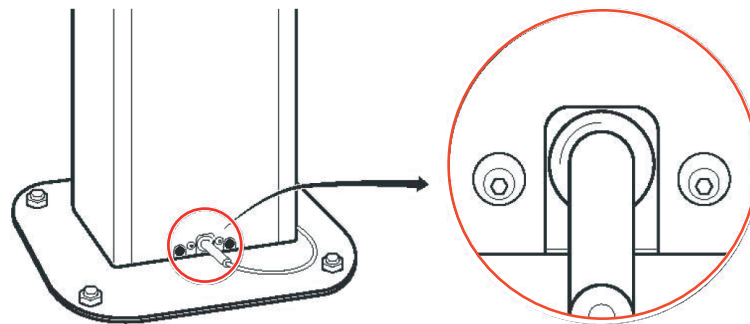

*Fig. 4-66 Removing the two screws at the Wallstand back*

# Installation

## Mechanical Installation of Wallstand

---

### 4.18.5 Install Counterweights

**CAUTION!**

*Squeezing hazard when the back cover is removed, your hands etc. may be caught in the internal moving parts (e.g. counterweights).*

*Do not remove the safety bolts and pins for transportation, unless it is stipulated in this manual.*

---

**CAUTION!**

*Install the counterweights before installing the detector.*

---

The counterweights are enclosed in the base board of the pallet. There are two types of counterweights enclosed: the final-adjustment and fine-adjustment counterweights.

#### Counterweights Tiltable, pieces, Non-tiltable, pieces

2.37 kg bottom plate marked "Bottom plate", already installed.

2.37 kg

0.26 kg

1. When installing or removing the counterweights, loosen the screws in position A, see figure below.

Release and remove the long screws (B) that fix the counterweights in their position.

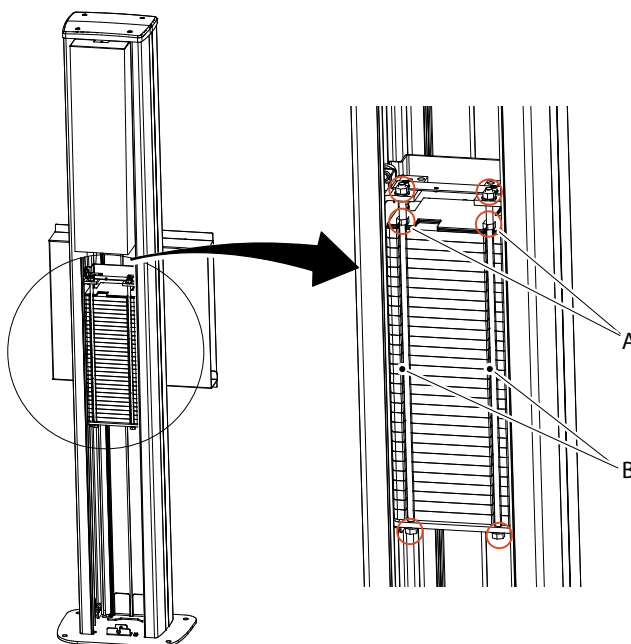

Fig. 4-67 Loosen screws

2. Install the enclosed counterweights from the back of the Wallstand.
3. Start to install the bottom plate.
4. Install the counterweights as in the figure below. Leave a space for removing the transport locking device.



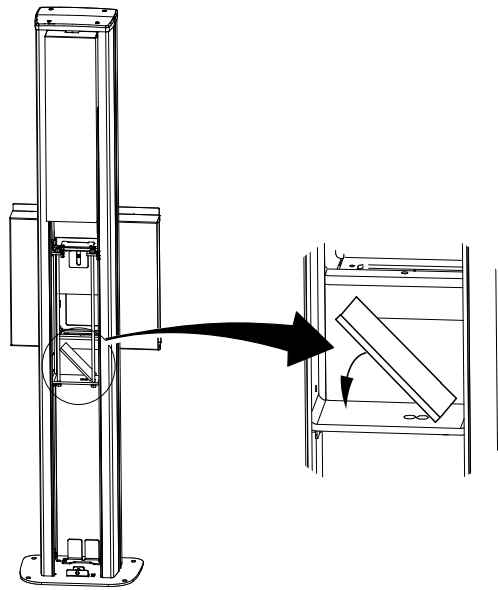

Fig. 4-68 Installing counterweights

**CAUTION!**

**Hazardous situation when removing the transport locking device the image receptor holder may become unbalanced.**

---

5. Remove three screws to the transport locking device and remove locking device, see figure below.

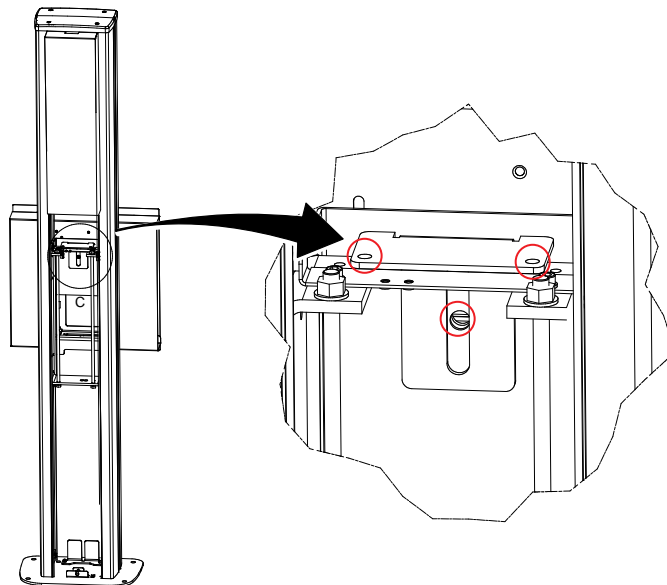

Fig. 4-69 Removing locking device

6. Install the remaining counterweights.
7. The counterweights must be fixed with two long screws (B) and six nuts. Three on each side to make sure that they are pulled together, see Fig. 4-67 Loosen screws.
8. Check that the Wallstand is balanced, push the image receptor holder down. It shall run equally smooth up as down, no scraping sound.

# Installation

## Mechanical Installation of Wallstand

---

### 4.18.6 Alignment of Wallstand

1. Place a spirit level on the column and check that the Wallstand is level.
2. Move the OTC and place the collimator 10 mm from the image receptor of the Wallstand according to Fig. 4-70 *Alignment of Wallstand*.
3. Move the OTC sideways, measure the distance.  
The distance should be 10 mm.
4. If the two measured values fail to correspond adjust the Wallstand column by moving it sideways.

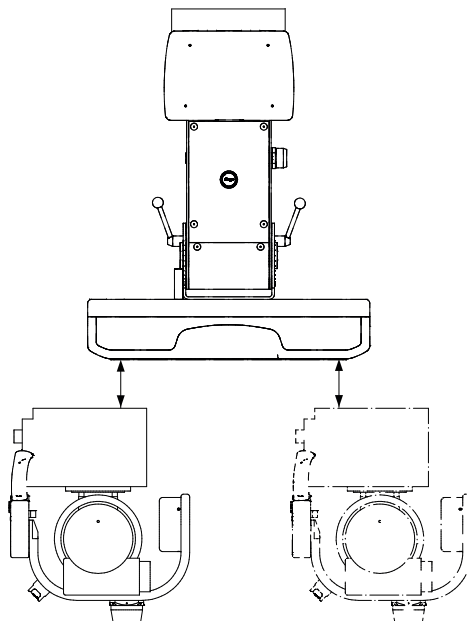

Fig. 4-70 *Alignment of Wallstand*

**Note!** \_\_\_\_\_

*It is important to mount the remaining 3 bolts into the floor.*

---

### 4.18.7 Anchor Location

The Wallstand must be installed on a solid base with sufficient load capacity. The floor must be able to withstand the pull forces supplied on the expansion bolts.

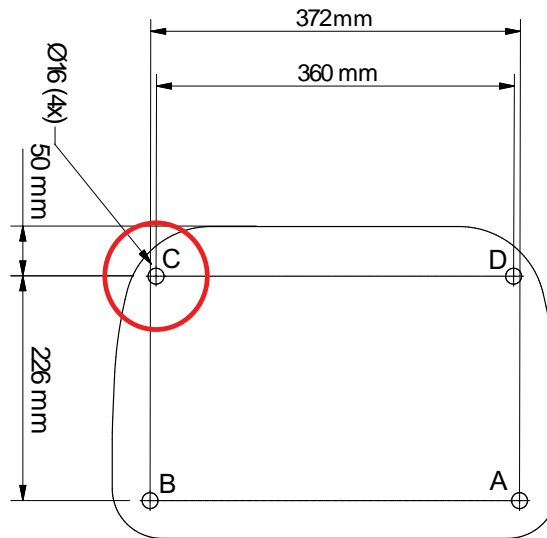

Fig. 4-71 Marking template Wallstand (Isolation plate)

Drill pilot holes for the anchor (outer diameter 12 mm) with the drill template. Depths of holes for the enclosed anchor are 45 mm, see Fig. 4-72 .

Pilot holes for the anchors:	Four locations
Outer diameter of the anchor:	12 mm
Anchor total length:	45 mm
Length of screws for the anchors:	10 mm
Drill diameter to be used:	12.5 mm

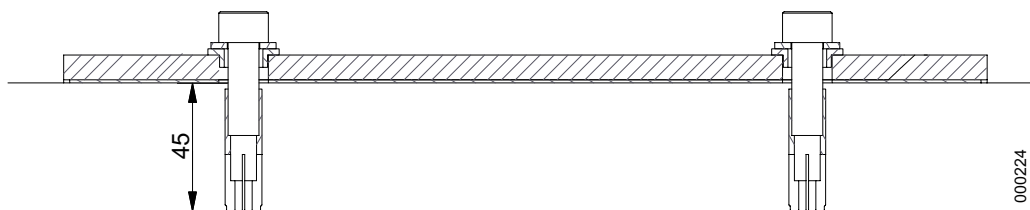

Fig. 4-72

1. Remove any chips left in the pilot holes with a dust collector etc. Top of the anchor may extend from the floor if chips are left in the pilot holes for the anchor when you insert the anchor.
2. Insert the enclosed anchor into the anchor hole and lightly tap it with a plastic hammer etc. and insert it 5-10 mm.  
Or, insert the anchor 5-10 mm using a manual drill.

# Installation

## Mechanical Installation of Wallstand

---

3. Fix the Wallstand to the floor with the enclosed M10 bolts, install the insulation washers and insulation cases, and fix the insulation plate.
  - Securing bolt : Four pieces (enclosed: M10×30).
  - Tightening torque: 25 Nm.
4. Insert the bolt cap into the bolt fixed in step 7.
  - Bolt cap: Four pieces (enclosed).

### **Note!**

---

*The insulation kit is designed to isolate System components, e.g. System cabinet, Table, Wallstand and Ceiling stand, from the hospital building.*



*The insulation kit will prevent stray currents from reaching the System e.g. via screw attachments. Stray currents can be present e.g. in reinforcement bars or in water pipes in a building. These currents can be of several hundred amperes and can affect the leakage current from the System to the patient and thereby the safety for patient and user. Stray currents in the building shall be regarded as a failure in the building but the insulation kit provides an extra safety barrier.*

*The insulation kit will also prevent unwanted ground loops due to e.g. electrical contact through the wall or floor lead X-ray shielding via screw attachments of the System components.*

---

### 4.18.8 Install Foot Control

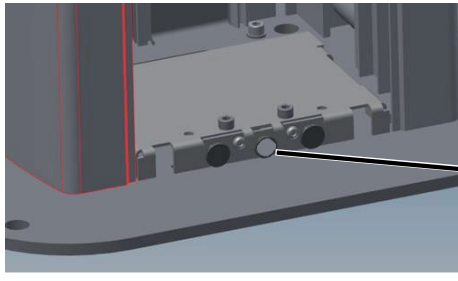
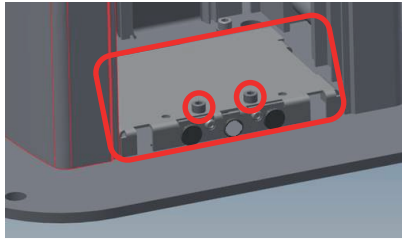
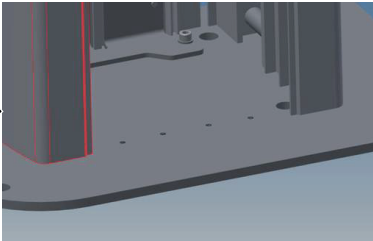
Connect the foot control on the lower back side of the Wallstand, see figure below position A. The foot pedal should be positioned so that it cannot be activated accidentally.

	A	
1. Remove two screws and remove the mounting bracket.		
	→	
2. Connect the foot control.		
		
3. Install the mounting bracket. See the figure below.		

### 4.18.9 Reassemble Back Cover, Wallstand

1. Reassemble the two screws (hex-head screws, 2.5 mm diameter) at the bottom of the back of this equipment.

# Installation

## Mechanical Installation of Wallstand

---

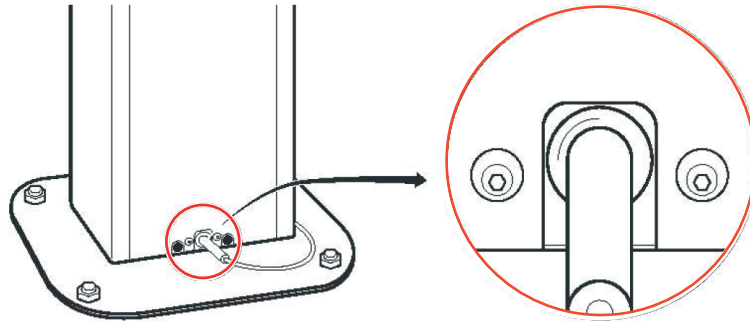

Fig. 4-73 Reassembling the two screws at the Wallstand back

2. Reassemble the two screws (hex-head screws, 3 mm diameter) under the electrical box.

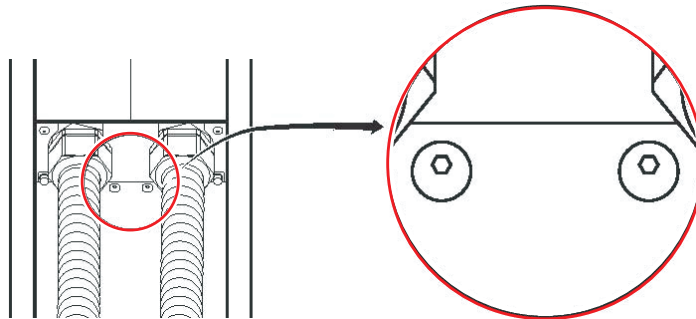
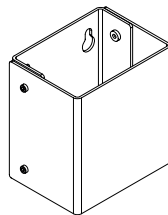

Fig. 4-74 Reassembling the two screws under the electrical box

### 4.18.10 Wall Attachment for Cable Hose

Install the wall attachment for the cable hose on the wall on a suitable place behind the Wallstand.



Picture A

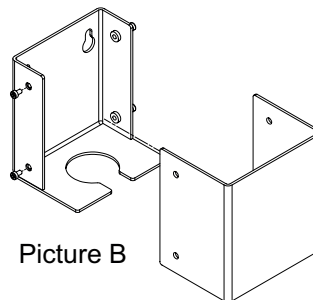

Picture B

Fig. 4-75 Wall attachments

### 4.19 Electrical Installation of Wallstand

#### 4.19.1 Wallstand Detector with Charging

When using a fixed detector or wireless detector with charging in the Wallstand, a power box or ac/dc box is pre-assembled to the Wallstand.

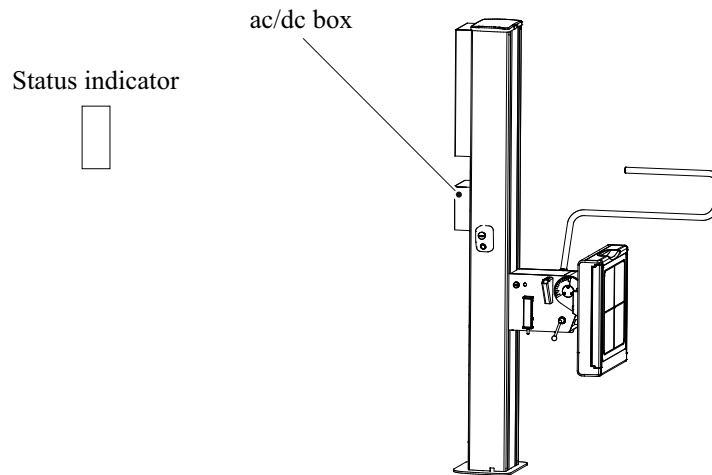

*Fig. 4-76 Power box — ac/dc box*

- Mount the status indicator at the wall. Position it for an apparent user view
- Route the 3.DETH01 to the switching hub.

For locations, see Fig. 4-76 *Power box — ac/dc box*.

# Installation

## Electrical Installation of Wallstand

---

### 4.19.2 Connect Wallstand

*Note!*

*The cables from the wall stand must be installed covered.*

*They shall not be placed on the floor.*

---

Wiring to electrical plate 4.2 is made in accordance with path 2.

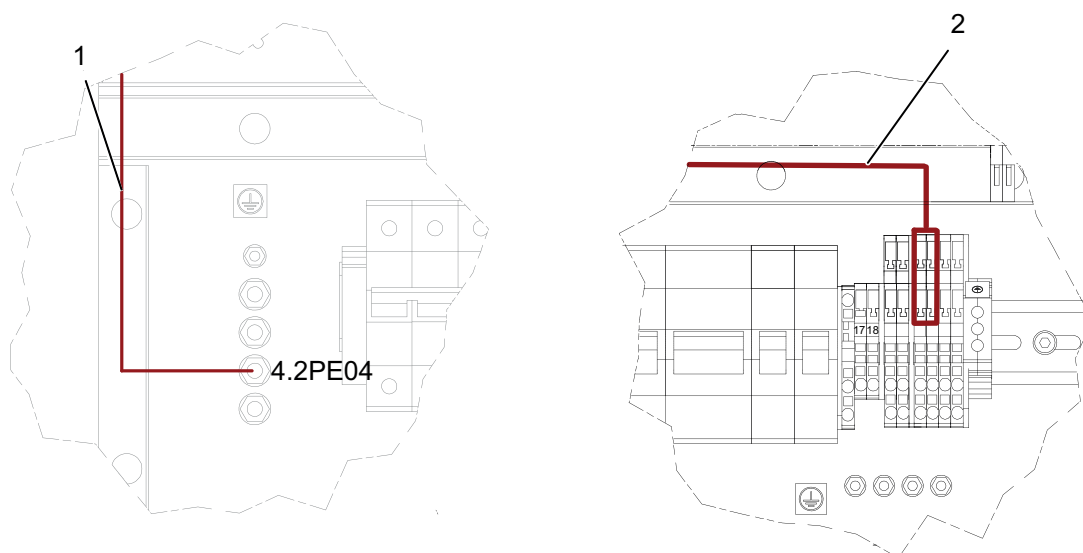

Fig. 4-77 Connecting the Wallstand

1. 3.0PE01
2. 2.3.DPOW01 (The cable is only present if a fixed detector, or a wireless detector with charging, is installed at the Wallstand)



# Installation

## Electrical Installation of Wallstand

Wiring to electrical plate 4.4 is made in accordance with path 3, see Fig. 4-29 *Cable paths*.

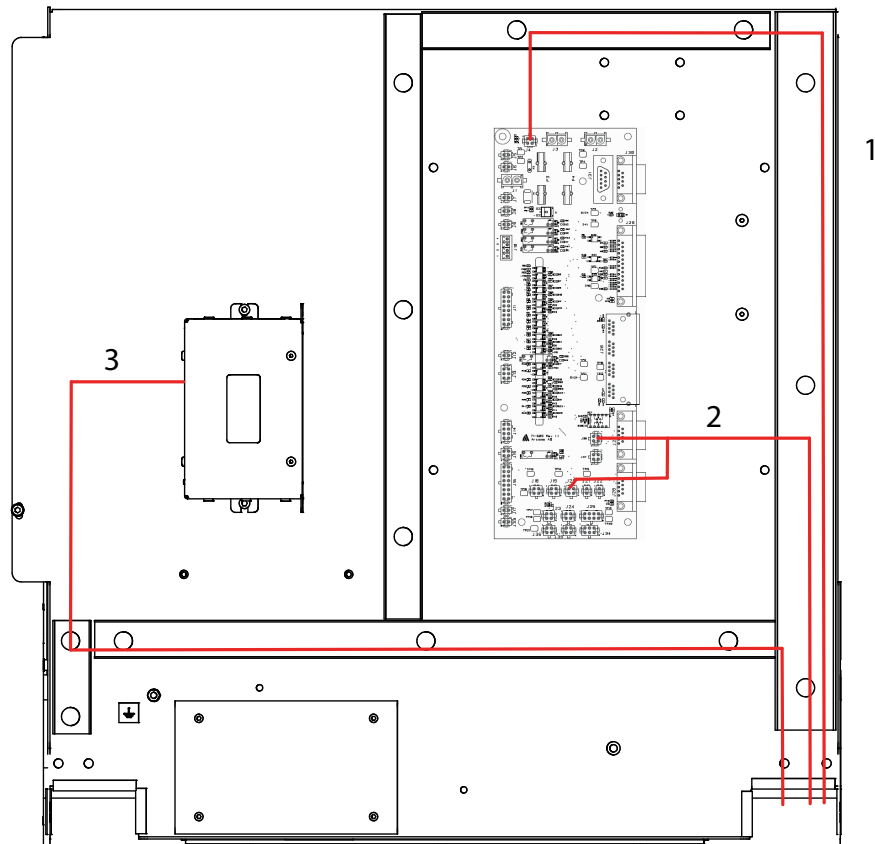

Fig. 4-78 Electrical plate 4.4

- |             |                      |
|-------------|----------------------|
| 1. 3.0POW01 | 4.4FIB01-J4          |
| 2. 3.0SIG01 | 4.4FIB01-J20 and J38 |
| 3. 3.0CAN01 | 4.4CB800_01_J2       |

# Installation

## Electrical Installation of Wallstand

---

Wiring to the generator is made in accordance with path 1.

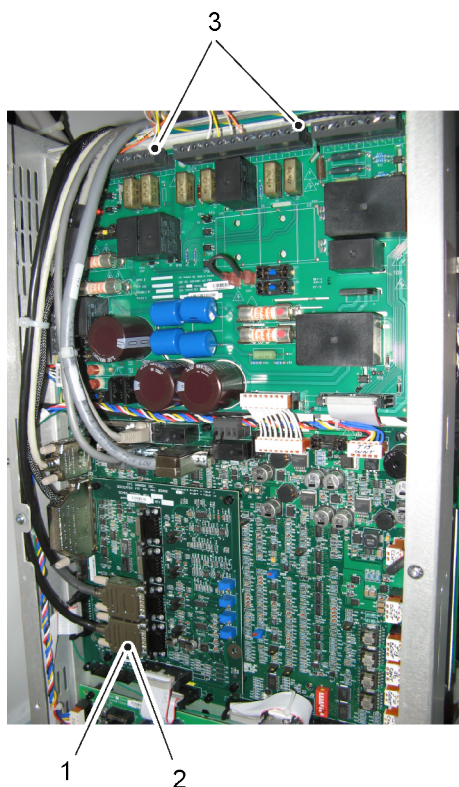

*Fig. 4-79 Connecting the Wallstand AEC*

1. 3.DAID01 — ION chamber
2. 3.DB3C01 (option) (channel 1) — Solid state chamber
3. The cable no. 3 is only present if a fix detector is installed at the Wallstand.

### 4.20 Mechanical Installation of 0181 Table

#### 4.20.1 Positioning the Pallet

*Note!* \_\_\_\_\_

*It is necessary to energize the Table to remove the covers. Put the pallet near the place where the power supply can be taken.*

---

#### 4.20.2 Unloading the Table

Unpack the Table from box.

Before lifting off the Table from the pallet, remove both the upper covers, and the front lower cover of the Table.

##### 4.20.2.1 Cover Removal Method

*(1) Preparing to Remove the Upper cover*

**CAUTION!** \_\_\_\_\_

**Check that the circuit breaker of the facility is turned off.**

---

1. Remove the service hatch (6 screws), and lift the hatch away.

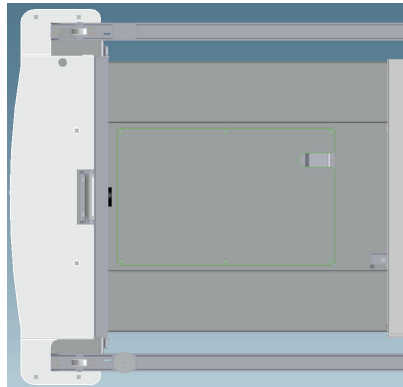

*Fig. 4-80 Service hatch*

2. Insert the power cable from the System cabinet into the device.
3. Reach your arm into the area on the right side of the TCB, and connect the power cable (2.POW01) to connector 2.1J01 circled in red in the diagram. (Connector 2.1J01 is panel mounted to the sheet metal part, located on the bottom plate of the main unit.)

# Installation

## Mechanical Installation of 0181 Table

---

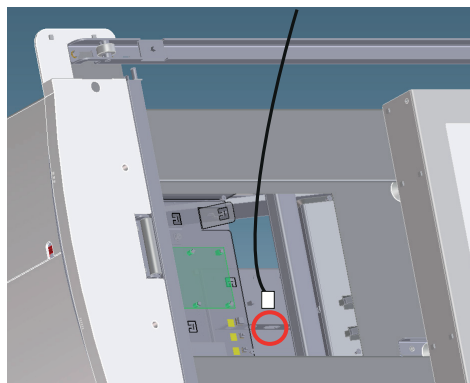

Connect power cable 2.POW01

Connector 2.1J01

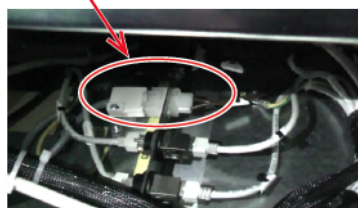

Power cable connected to connector 2.1J01

4. Turn on the System, at the generator console.

# Installation

## Mechanical Installation of 0181 Table

### (2) Removal of the Upper Cover



#### **WARNING!**

**All work without covers, shall be done with the voltage turned off.**

Both upper covers (front and back) are removed in the same way.

1. Press the "X/Y button" on the kick box to release the table frame. Move the table frame to the position at which the cover fixing screws can be removed, and remove the 2 screws at both "A" locations (a total of 4 screws).

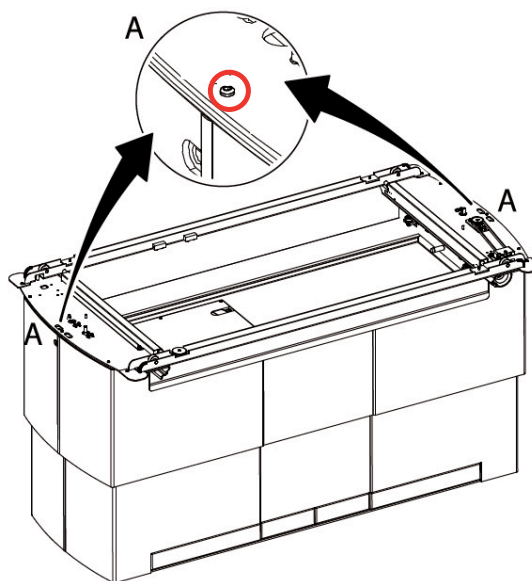

Fig. 4-81 Remove the 2 screws at "A"

2. Move the table frame again, to a new position where the 2 screws at the four "B" locations (a total of 8 screws) can be removed. See Fig. 4-82 Remove the 8 screws at "B"

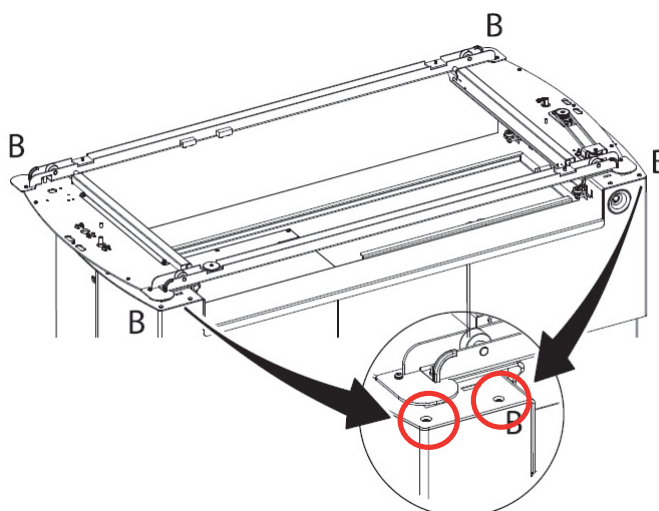

Fig. 4-82 Remove the 8 screws at "B"

# Installation

## Mechanical Installation of 0181 Table

---

**Note!** \_\_\_\_\_

The upper cover is fastened with these screws, and will loosen when the screws at the “B” locations, are removed.

---

**Note!** \_\_\_\_\_

Be careful, the emergency stop button is attached to the upper cover with the circuit cable (2.3J03, 2.4J03) connected. When removing the upper cover, also remove the emergency stop cable from the connector, unclip carefully.

---



Fig. 4-83

3. Remove the cover from the working area.

# Installation

## Mechanical Installation of 0181 Table

### (3) Removal of the Front Lower Cover

1. Loosen the front screw of the lower cover at the "C" locations (one at each side), shown in the graphic below.
2. Unlock the locking parts on both sides.

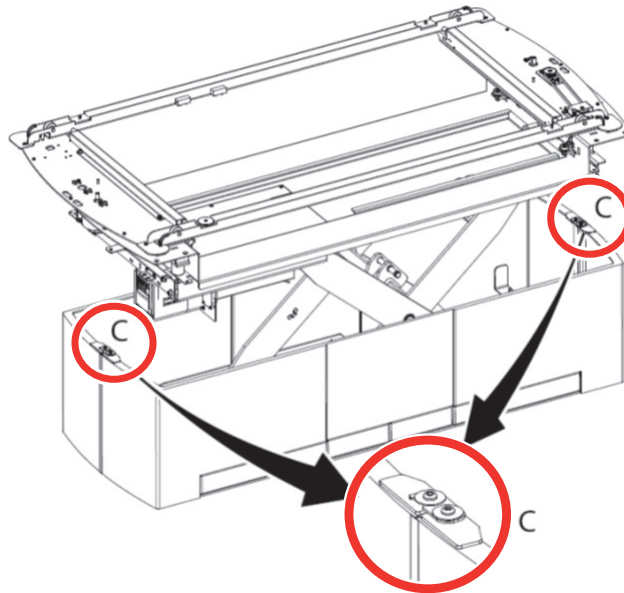
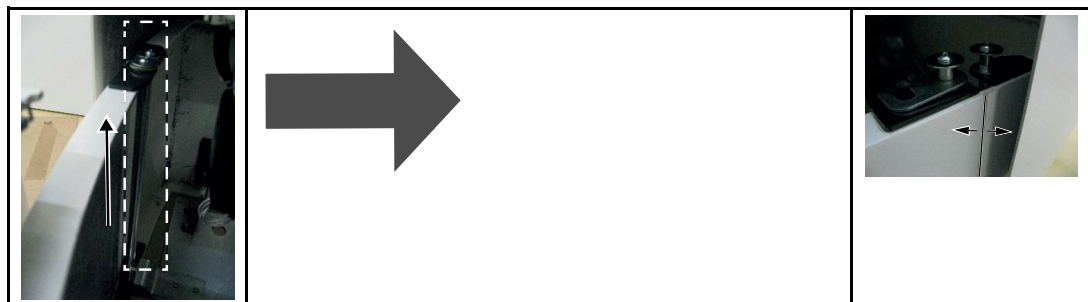

Fig. 4-84 Front screw of lower cover



3. Pull up the bar extending below the screw location and remove the lower cover by lifting and pulling out the plate. This procedure shall be done at both sides.



3. Remove the cover from the working area.

# Installation

## Mechanical Installation of 0181 Table

---

### 4.20.2.2 Unload Table from Pallet

#### **Orientation of Table**

Before placing the Table on the floor, check for enough free space around the Table, to allow free movement.

See the Planning Guide for further information of required space around the Table. Plan the positioning of the Table in accordance with the room layout.

It is possible that a cable duct is already made in the floor where the Table shall be placed.

#### **Unloading**



#### **WARNING!**

*All work without the covers, shall be done with the voltage turned off*

---



#### **WARNING!**

*Do NOT enter under the table while power supply of the table is ON and the table is travelling vertically (up or down).*

---



#### **WARNING!**

*Squeezing hazard can occur between the vertical lift segments when moving in Z-direction*

---

#### **CAUTION!**

*Before unloading the Table, verify that the safety clamp is attached in transport position.*

---

Before unloading the Table from pallet, the covers shall be removed.

1. Release the Table from the pallet, by removing the 4 bolts.

#### **CAUTION!**

*The Table may overturn when not bolted to the pallet or the floor.*

---



### 4.20.3 Safety Clamp



#### **WARNING!**

*Remove the safety clamp before starting to move the Table in Z-direction.*



#### **WARNING!**

*Be careful when moving the safety clamp between different positions.*

#### 4.20.3.1 Safety Clamp Use

The safety clamp has two areas for use:

- to secure the device at service or maintenance.
- to secure the device during transport

The safety clamp has three positions for different occasions:

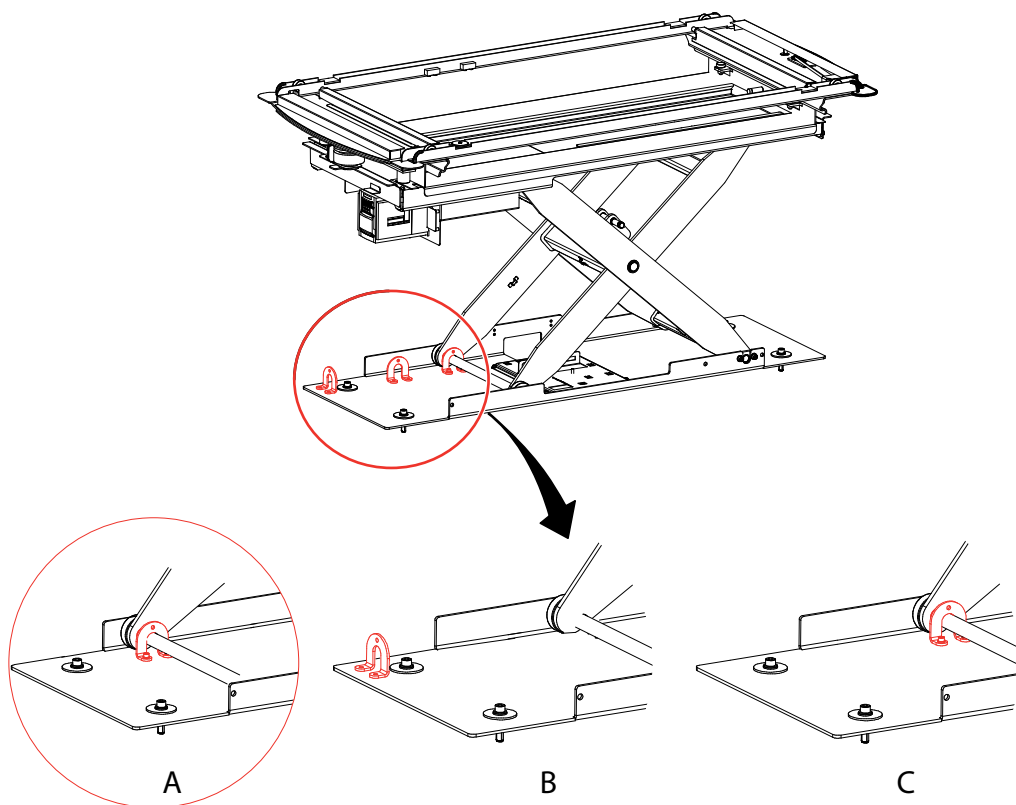

*Fig. 4-85 Safety clamp positions*

Safety clamp position:

- A During transport
- B During operation (parking position).
- C During service performance.

# Installation

## Mechanical Installation of 0181 Table

---

### 4.20.3.2 Removal of Safety Clamp



**WARNING!**

---

*Do NOT enter under the table while power supply of the table is ON and the table is travelling vertically (up or down).*

---



**WARNING!**

---

*Turn off the system when you need to enter under the table in order to attach or detach the safety clamp or to install the table.*

---

For facilitating a removal of the safety clamp, first remove the covers and the service hatch.

1. Remove the 2 screws at the safety clamp.
2. Move the safety clamp from the transport position to the service position, and attach the safety clamp in the service position by the 2 screws.

### 4.20.4 Insulation

**Note!**—

*Before starting to fasten the Table to the floor, ensure that there is enough space for the Table movements, at the room.*

---

Put the enclosed expanders in the holes. Place a mandrel in the expander and drive in 5-10 mm to attach the expander. Place the Table over the drilled holes and install the insulation plate and washers according to figure below.

**Note!**—

*The insulation kit is designed to isolate System components, e.g. System cabinet, Table, Wall stand and Ceiling stand, from the hospital building.*

*The insulation kit will prevent vagabond currents from reaching the System e.g. via screw attachments. Vagabond currents can be present e.g. in reinforcement bars or in water pipes in a building. These currents can be of several hundred amperes and can affect the leakage current from the System to the patient and thereby the safety for patient and user. Vagabond currents in the building shall be regarded as a failure in the building but the insulation kit provides an extra safety barrier.*

*The insulation kit will also prevent unwanted ground loops due to e.g. electrical contact through the wall or floor lead X-ray shielding via screw attachments of the System components.*

---

# Installation

## Mechanical Installation of 0181 Table

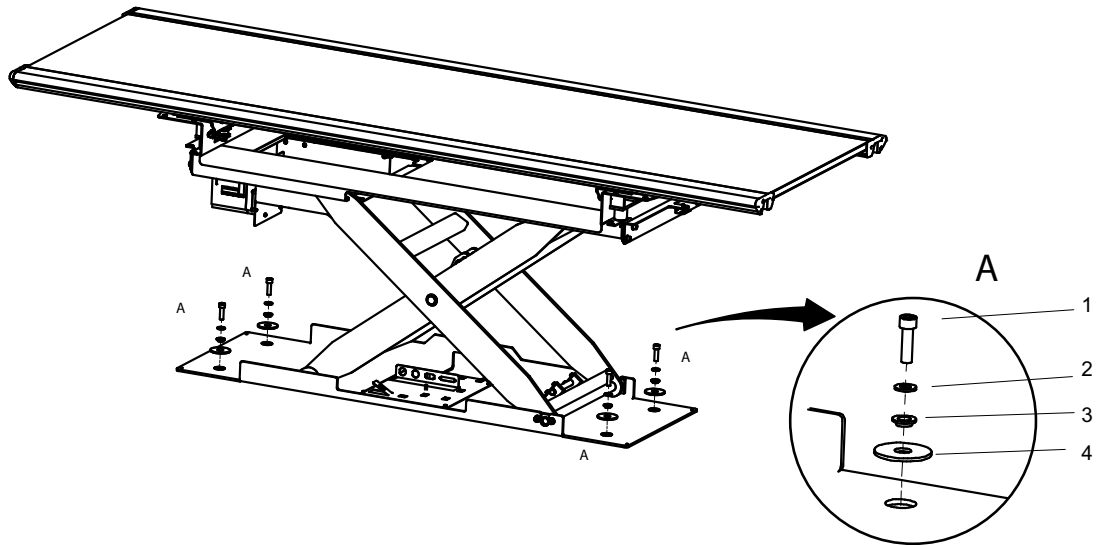

Fig. 4-86

1. Bolt
2. Washer
3. Insulation washer
4. Washer

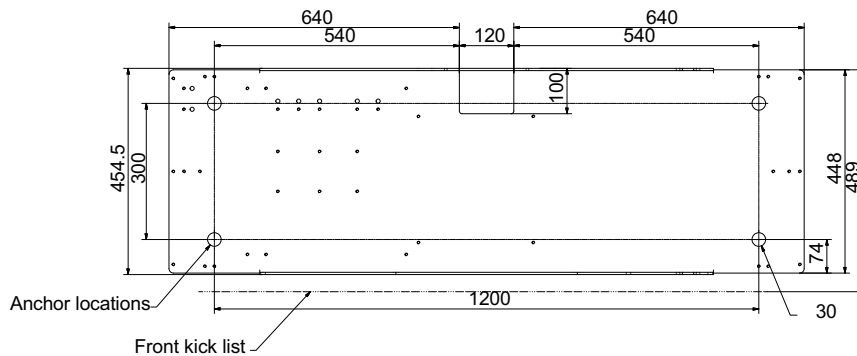

Fig. 4-87 Measurements for the Table bottom plate

### 4.20.5 Adjust Horizontal Alignment

Place a spirit level on the center of the Table top. The Table shall be  $90^\circ$  with a tolerance of  $\pm 0.5^\circ$ .

#### 4.20.5.1 Shims

Shims are used to adjust differences in the floor gradient. It is possible to use shims  $\pm 10$  mm, shims should then be under the whole track for the wheels, see marks in the figure below.

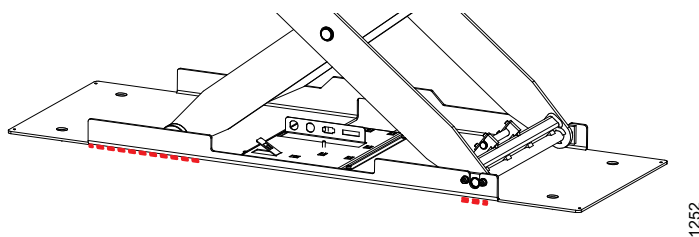

Fig. 4-88 Adjusting horizontal alignment

### 4.20.6 Attachment to Floor

This shall be done when the Table is in its exact position.

The maximum deviation between the floor attachment points should be  $\pm 10$  mm, see further requirements on the floor in the OMNERA® 400T Planning Guide.

Make marks on the floor for holes and cable outlet, where the Table shall be placed. Drill the holes 12 mm diameter for the expanders. The hole depth for the enclosed expanders shall be 45 mm, see figure below. For an alternative attachment to the floor, see planning guide for requirement of the floor and demands on attachment.

Bolt the Table into the floor. Use M10 screws and apply Loctite 243.

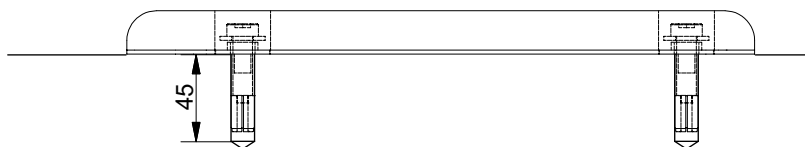

Fig. 4-89

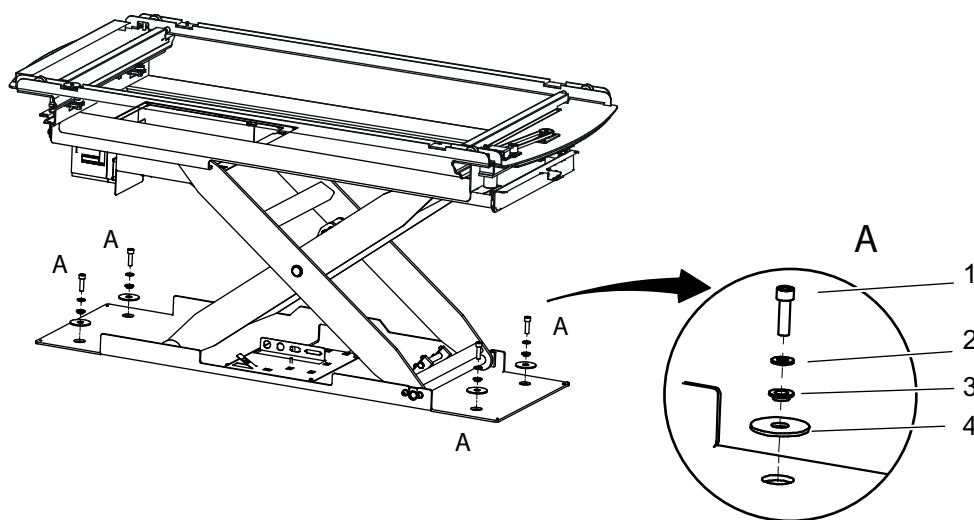

Fig. 4-90

### 4.20.7 Micro Switch End Stops

Check the upper and lower end stops for the Table Z direction. The lowest Table position shall be 500 mm and the highest position 800 mm. See Fig. 4-91

If necessary, make adjustments by loosening the valid screw, and then slide the micro switch to the correct position.

# Installation

## Mechanical Installation of 0181 Table

---

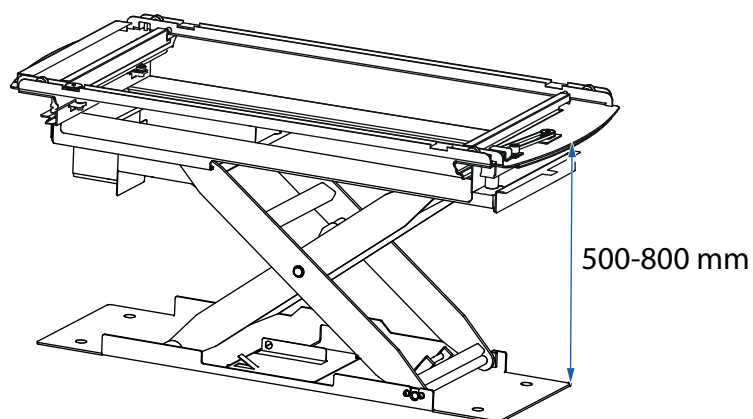

*Fig. 4-91*

The left micro switch is controlling the lower table end stop.

The right micro switch is controlling the upper table end stop.

### 4.20.8 Attachment of Foot Pedal (X/Y/Z)

Connect the foot pedal according to figure below.

The contact should have the reference point 2.1J05.

The foot pedal shall be positioned so that it cannot be activated accidentally.

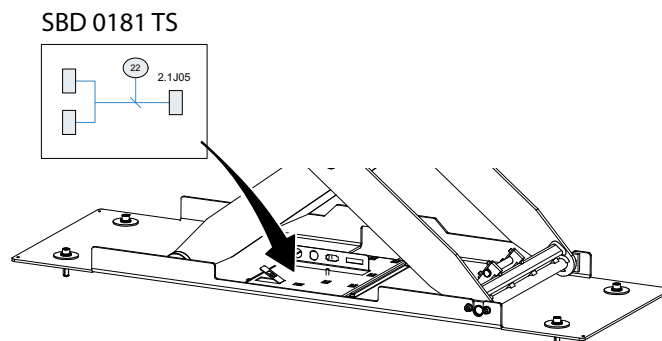

*Fig. 4-92 Foot pedal attachment*

# Installation

## Mechanical Installation of 0181 Table

### 4.20.9 Attachment of Maneuver Hand Control

Connect the maneuver hand control according to figure below. The contact should have the reference point 2.3J02 or 2.4J02 (for the Collimator hand control use connection point 2.3J01 or 2.4J01).

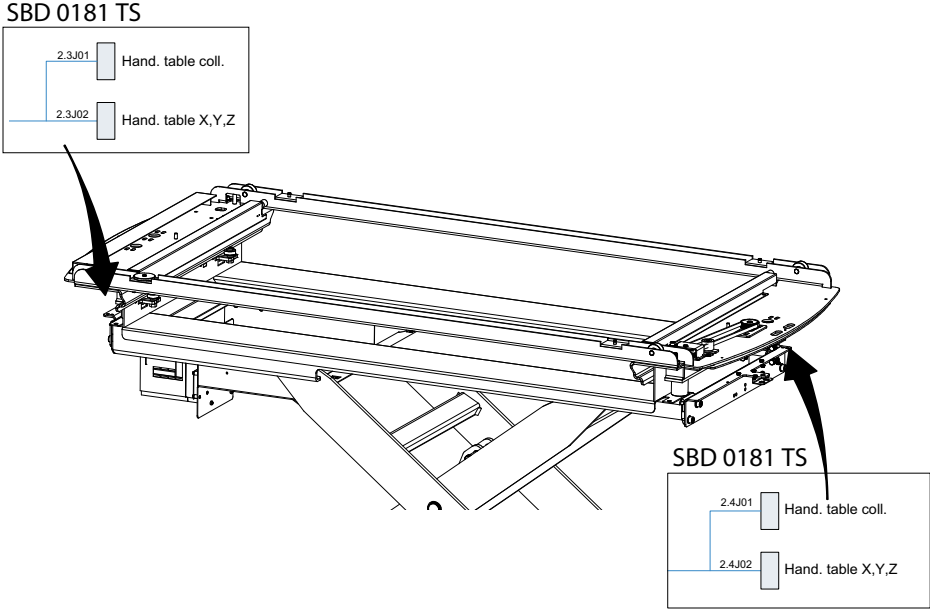
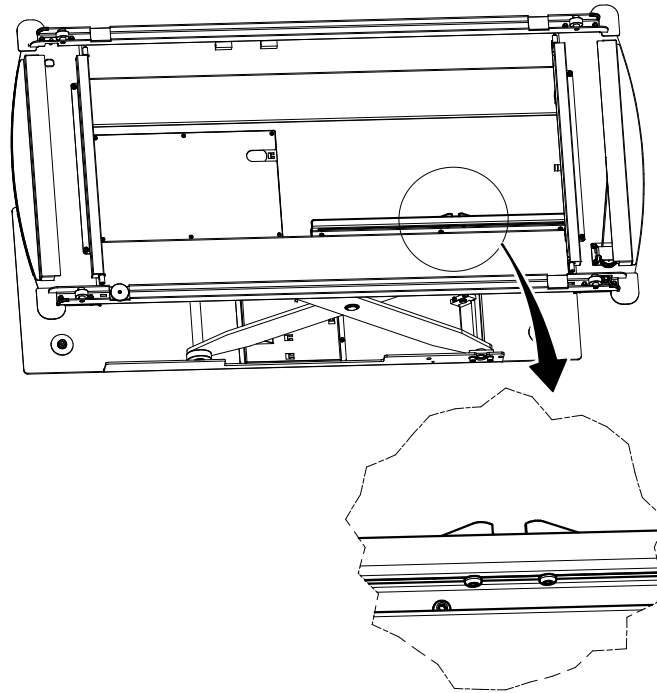

Fig. 4-93 Hand control attachment



### 4.20.10 Adjust Detector Holder

The detector holder can be adjusted by moving the index, see figure below.



*Fig. 4-94 Detector holder adjustment*

### 4.20.11 Remove the Red Safety Clamp

Set the Safety clamp in position "B", see Fig. 4-85 *Safety clamp positions*.

### 4.20.12 Reassemble the Covers

Reassemble all the covers including the cover for the electrical plate.

Attach the covers, see 4.8.2 *Remove Covers, Cabinet*, Page 128

Remember to assemble the lists between the lower covers.

**CAUTION!**

---

**Be careful to connect the cables for the emergency stop in accordance with the markings.**

---

# Installation

## Mechanical Installation of 0181 Table

---

### 4.20.13 Two column table (option)

#### 4.20.13.1 Orientation of two column table

Before placing the table on the floor, check for enough free space around the table, to allow free movement.

See the Planning Guide for further information of required space around the table. Plan the positioning of the table in accordance with the room layout.

# Installation

## Mechanical Installation of 0181 Table

### Clearance to wall

#### Note!

According to IEC60601-1 clause 9.2.2.2, the clearance between the table top and the wall shall be minimum 500 mm.

There are squeezing hazards between the moving table top and the wall. The measurements in the figure are important, according to IEC60601-1 clause 9.2.2.2.

Consider maximum cable length. The mechanical stop can be moved closer to the center of the table top. The stroke of the table top will then be shorter.

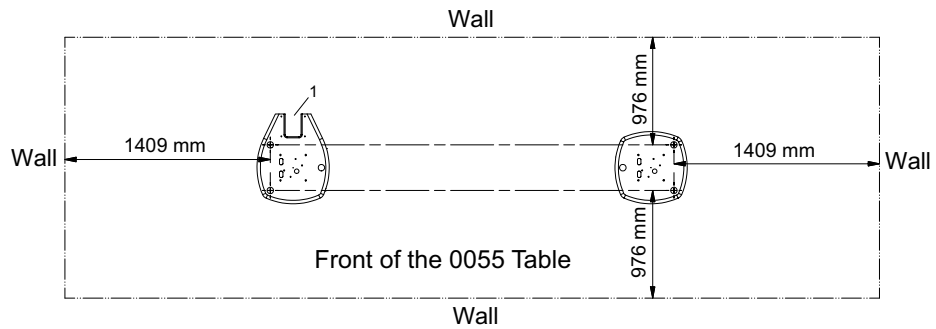

Fig. 4-95 Necessary space, table movement

### Cable duct in floor

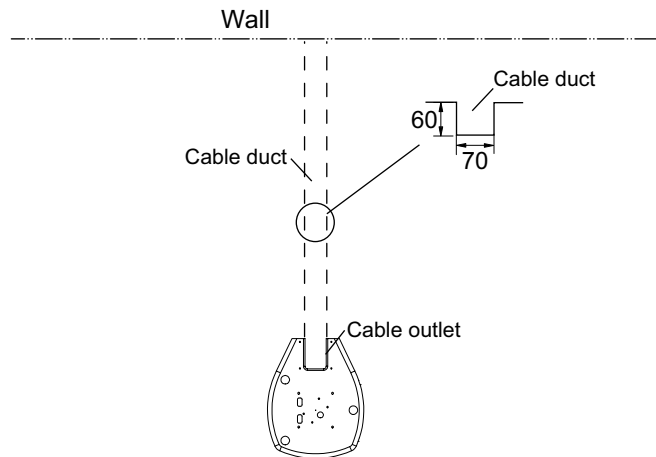

Fig. 4-96 Cable duct in the floor

# Installation

## Mechanical Installation of 0181 Table

---

### 4.20.13.2 Unload two column table



#### **WARNING!**

---

*Do not sit on the table until it is attached to the floor.*

*The table may overturn when not bolted to the pallet or the floor.*

---



#### **WARNING!**

---

*Do not tilt the table when unloading.*

*The columns may bend towards the middle when the table is lifted.*

*Two persons must keep the columns vertical.*

---

1. Slide/lift off the table from the pallet by grabbing underneath the table frame. Do not tilt the table, keep the columns vertical.
2. Place the insulation plate (A) under the footplates.

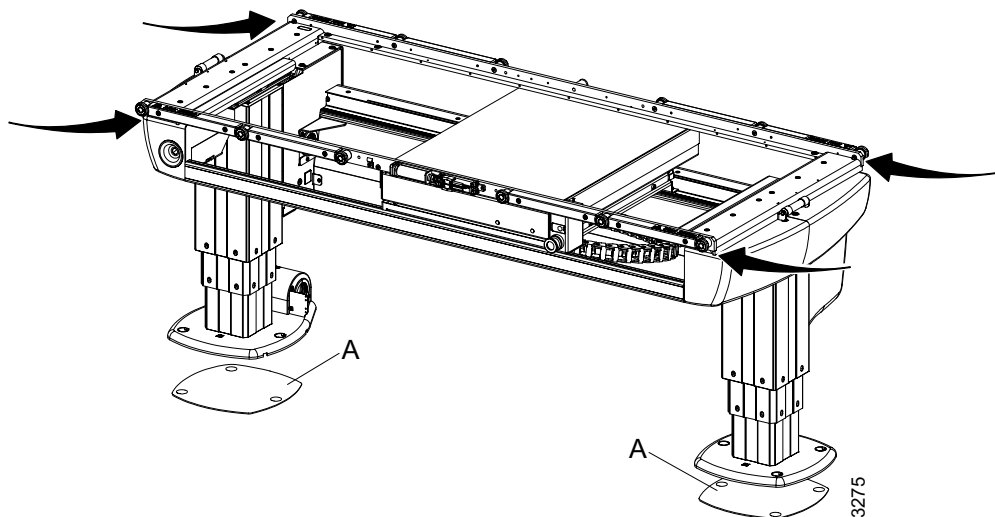

Fig. 4-97 Insulation and alignment

# Installation

## Mechanical Installation of 0181 Table

---

### *Transport protection, detector holder*

Remove the transport protection of the detector holder, one on each side.

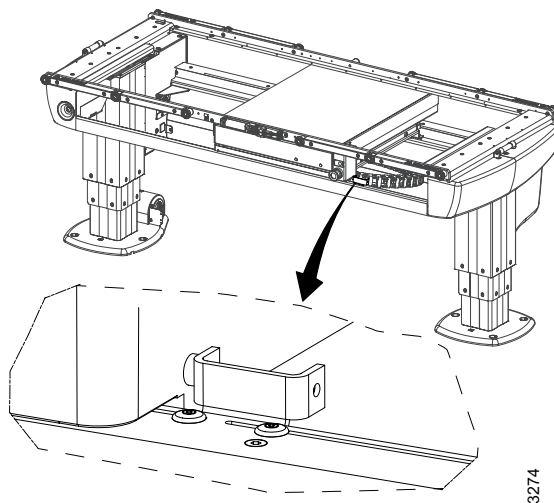

Fig. 4-98

# Installation

## Electrical Installation of Table

### 4.21 Electrical Installation of Table

#### 4.21.1 Connect Table

*Note!*

*The installation cables from the Table must be installed covered. They shall not be placed on the floor.*

Connect the Table according to the figures.

Wiring to electrical plate 4.2 is made according to cable path 2.



Fig. 4-99 Connecting the Table

1. 2.0PE01

2. 2.0POW01

# Installation

## Electrical Installation of Table

Wiring to electrical plate 4.4 is made according to cable path 3, see Fig. 4-29 *Cable paths*.

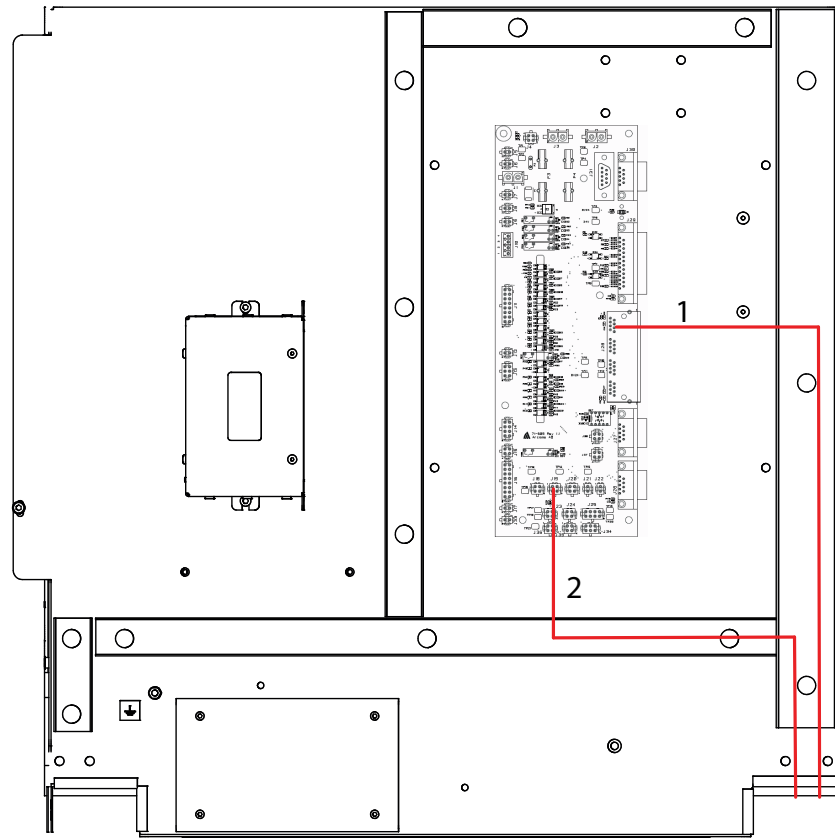

Fig. 4-100 Connecting the Table

- 1. 2.0CAN01
- 2. 2.01SIG01

- 4.4FIB01 J28-P4
- 4.4FIB01-J19

# Installation

## Electrical Installation of Table

---

Wiring to the generator is made according to cable path 1.

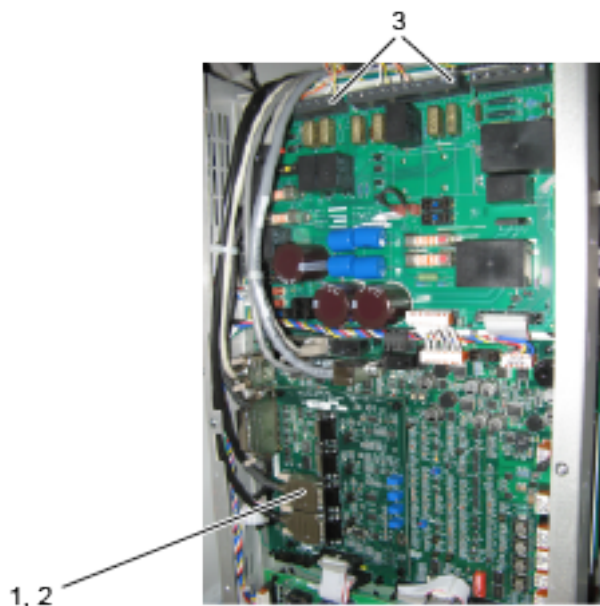

*Fig. 4-101 Connecting the Table AEC*

- |   |   |
|---|---|
| 1. 2.0SIG03 (channel 2) (Standard) —<br>ION chamber | 2. 2.DB3C01 (Option) — Solid state<br>chamber |
|---|---|



### 4.22 Finalize Table Installation

Switch on the power to the System from the mains switch.

Switch on the power to the System from the generator console.

#### 4.22.1 The Mechanical Stop

Beneath the table top there are mechanical stops installed, see figure below.

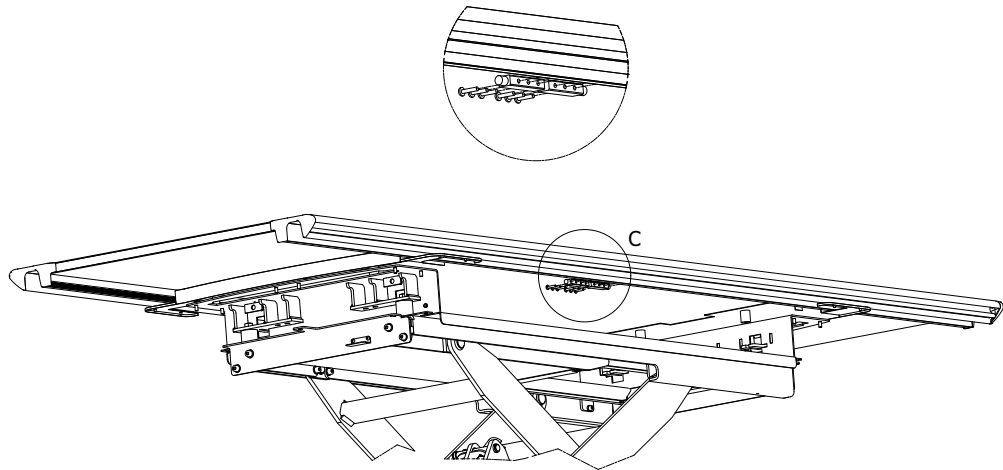

*Fig. 4-102 Table mechanical stops*

# Installation

## Finalize Table Installation

### 4.22.2 Install Table Top

Start with removing the mechanical end stops, see Fig. 4-102 *Table mechanical stops*

Check that the Table top is placed at the right position. There is a rack rail on one side of the Table top, and this should be put to the same side as the pinion at the Table.

Lift the Table top onto the Table frame from one side to another so it can roll on the wheels. See figures below.

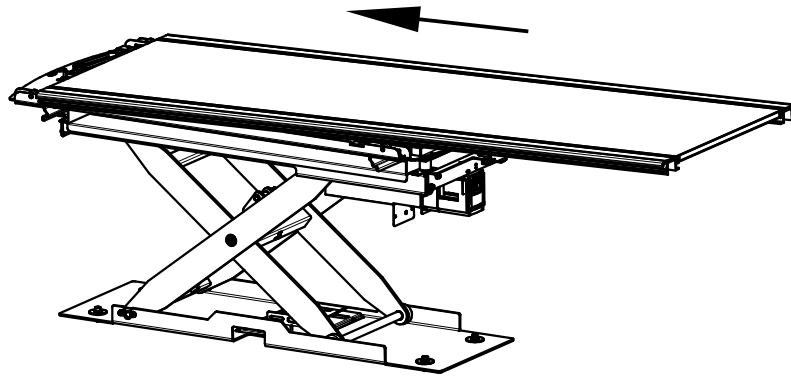

Fig. 4-103 Slide on the wheels to one side

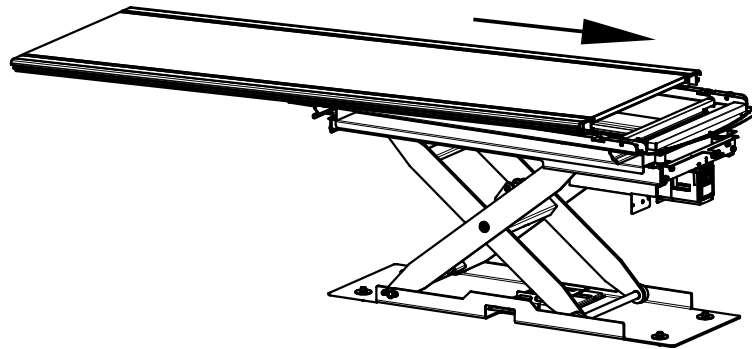

Fig. 4-104 Slide to the other side

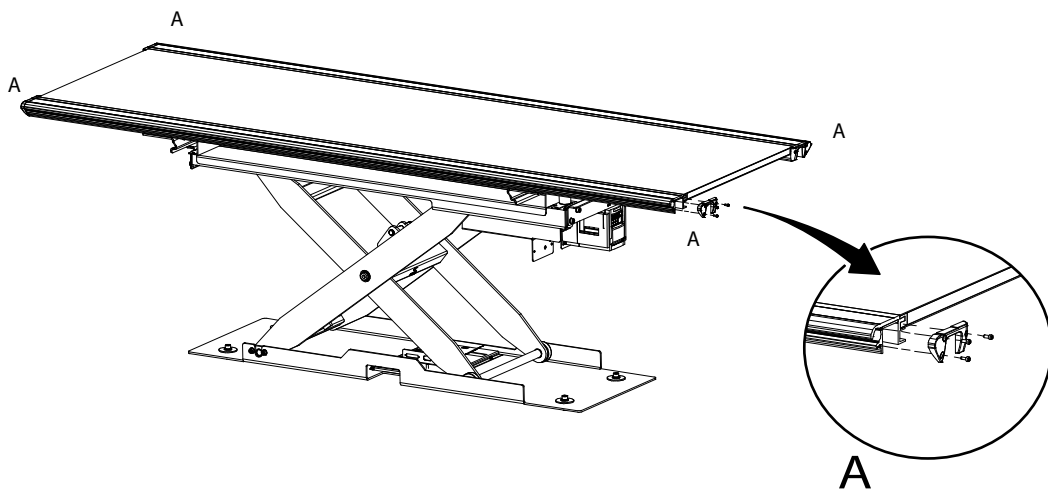

Fig. 4-105 Install the four end covers (A) according to figure

Finalize with installing the mechanical end stops, see Fig. 4-102 *Table mechanical stops*.



### **WARNING!**

---

*It is important that the end stops are correctly installed.*

---

Switch off the power to the System from the generator console.

Switch off the power to the System from the mains switch.

#### **4.22.3 Two column table (option)**

##### *Note!*

---

*Be aware of the difference between the two rails (A) and (B).*

---

##### *Note!*

---

*When sliding the table top in place, make sure the friction pads of table top brakes aren't damaged.*

---

1. Remove one of the table top end stops.
2. Switch on the power to the table and release the X/Y brake.
3. Press the brake pad against the magnets. Keep the brakes released (button pressed) when carefully sliding the table top in place.  
Rail (B) has to be installed on the front.
4. Install the mechanical stop (A), use Loctite 243. Tighten the bolts with 24 Nm.
5. Check that the table top runs smoothly.
6. Check the function of the table top brake.

# Installation

## Finalize Table Installation

---

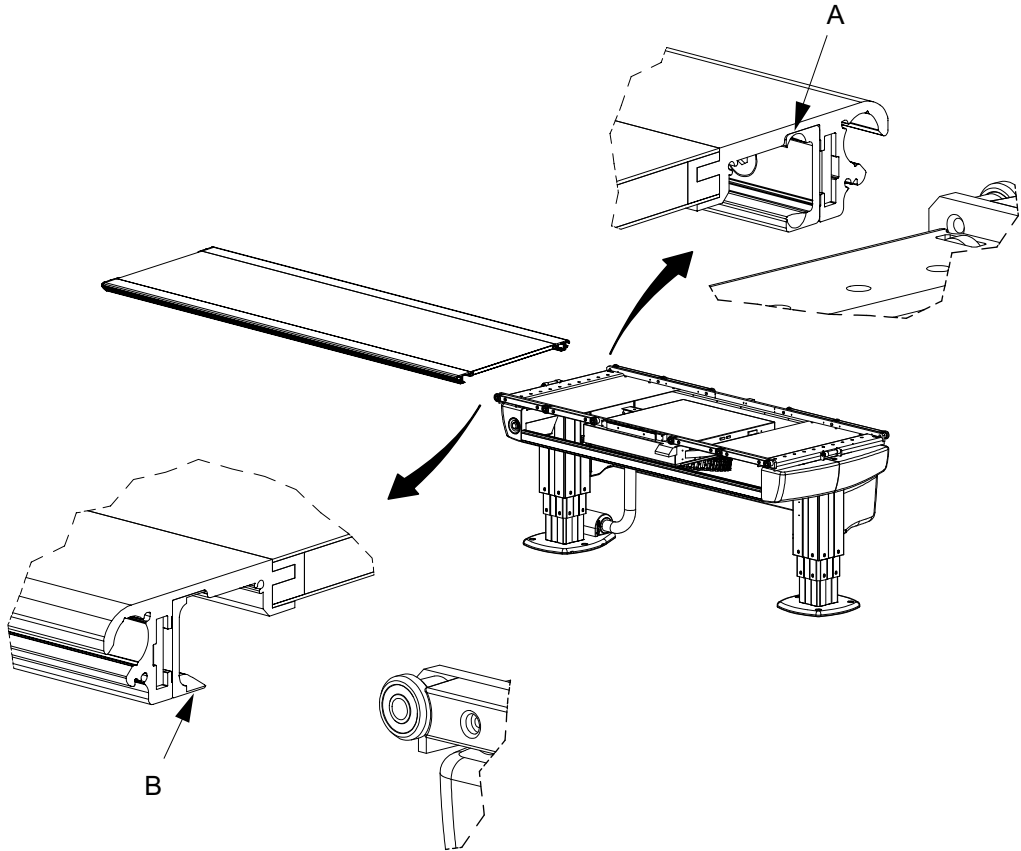

Fig. 4-106

### 4.22.4 Installation of foot control Two column table (option)

Install the foot control and connect the cable 2.4J01 or 2.4J02 according to Fig. 4-107 *Connect the foot control X/Y/Z or foot control X/Y separate (option)*.

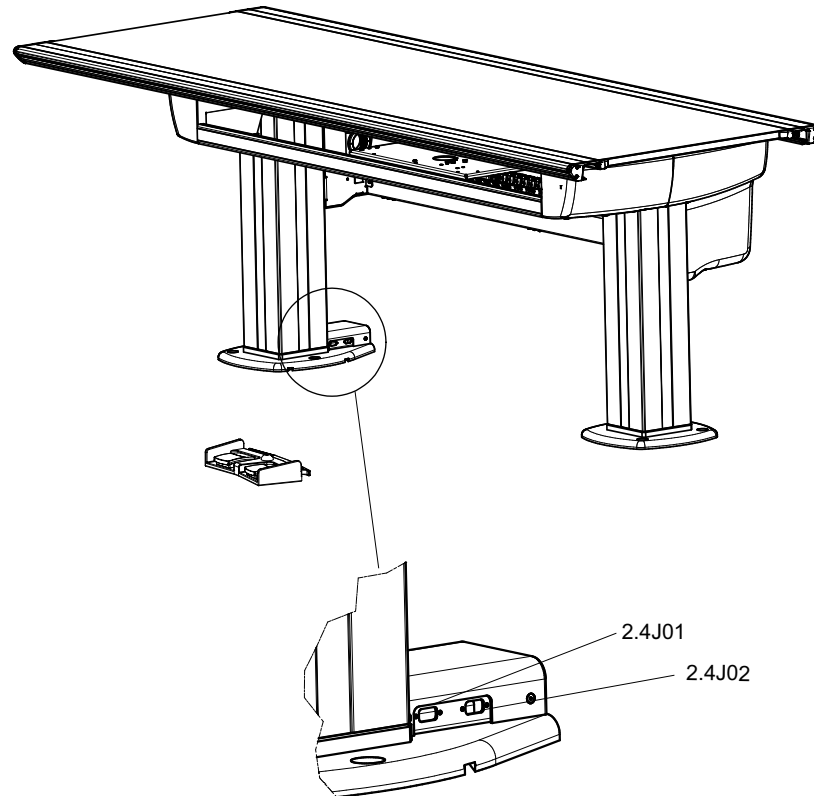

Fig. 4-107 *Connect the foot control X/Y/Z or foot control X/Y separate (option)*

# Installation

## Finalize Table Installation

---

### 4.22.5 Installation of foot control strip type two column table (option)

1. Install the foot control X/Y between the two columns.

The foot control X/Y shall be placed against the foot plate or in a cable duct.

**Note!** \_\_\_\_\_

*Open installation of the foot control X/Y cable is not allowed.*

---

2. Place the cable from the foot control X/Y (A) in the track (C) underneath the foot plate.
3. Attach the foot control X/Y to the floor with double-sided tape.

**Note!** \_\_\_\_\_

*The foot control X/Y is attached to the floor with double-sided tape, because of isolation between the floor and the foot control.*

---

4. Cut the cable in suitable length and connect on contact 2.4J03 (B).

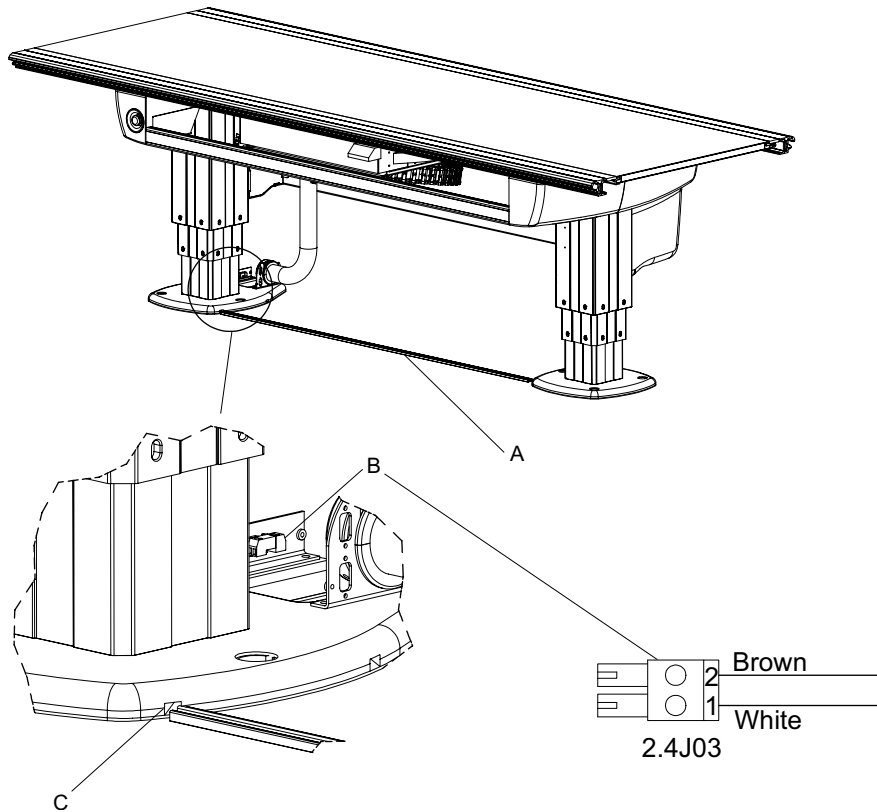

Fig. 4-108 Connect the foot control X/Y

### 4.23 Protective Earth

#### 4.23.1 Check Protective Earth

Make sure the protective earth cables are connected and the bolts are tightened, see Fig. 4-109 *Checking the protective earth cables and bolts*.

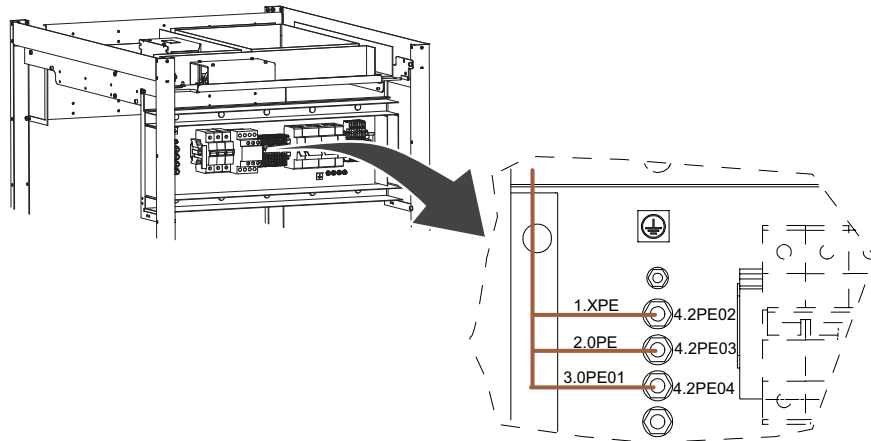

Fig. 4-109 *Checking the protective earth cables and bolts*

# Installation

## Protective Earth

---

### 4.23.2 Measure Protective Earth



#### **WARNING!**

***Make sure the mains power is switched off before the mains protective earth cables are disconnected.***

---

Protective earth is measured to ensure that all cables are correctly connected.

A visual or audible device (Ohmmeter, buzzer, etc.) may be used to indicate grounding continuity.

Before measuring protective earth on the ceiling unit, Table and Wallstand as follows, make sure the mains protective earth cable from the building is not connected, see Fig. 4-110 *Measuring protective earth*.

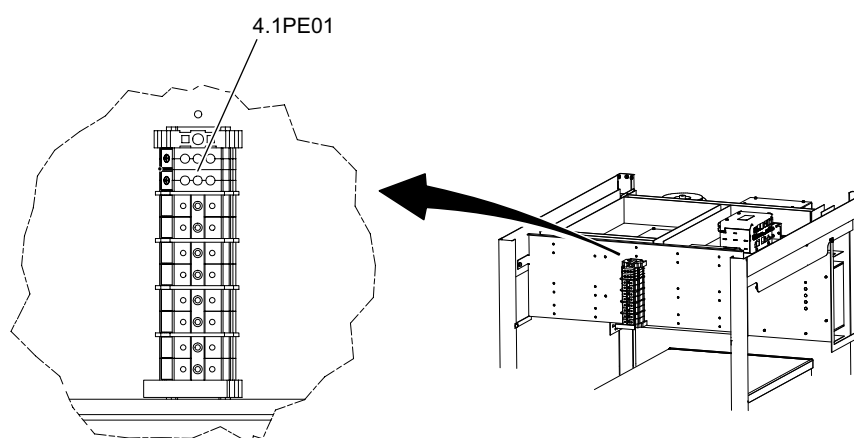

*Fig. 4-110 Measuring protective earth*



### 4.23.3 Protective Earth CS

Measure the continuity between the measuring point 1.CS and the ground terminal 4,1PE01.

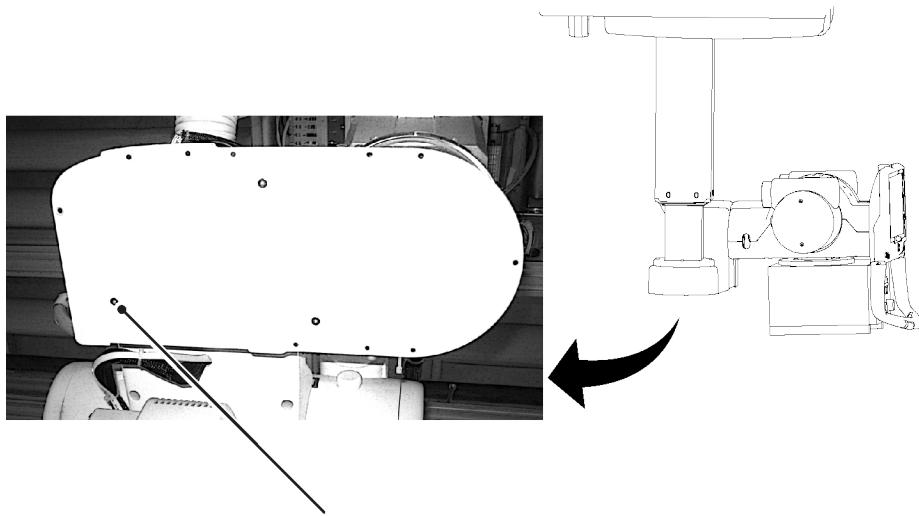

Fig. 4-111 Measuring point 1.CS

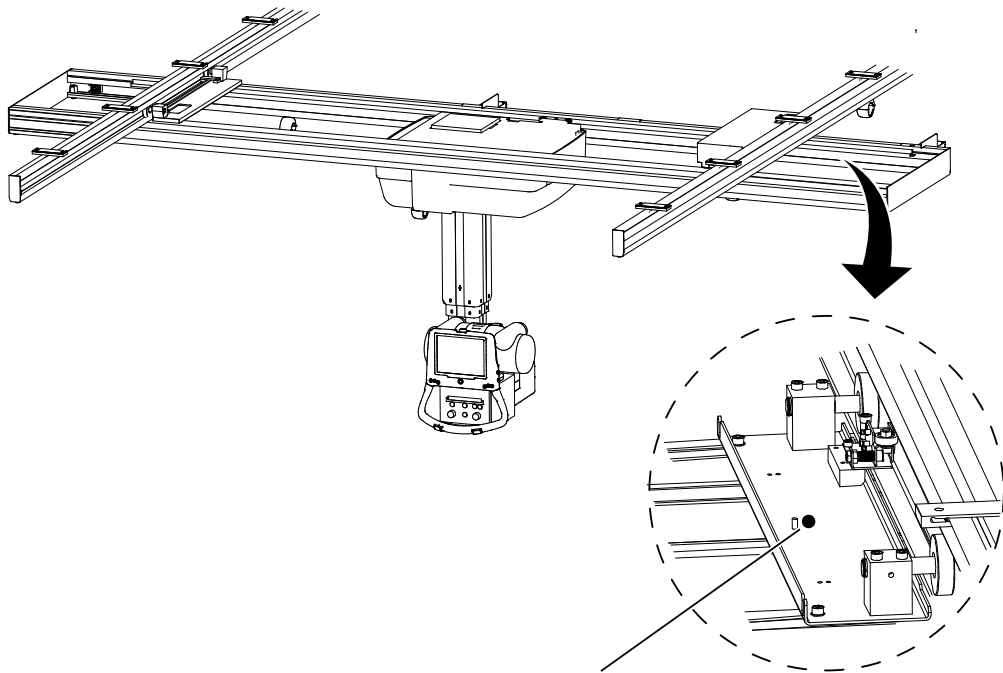
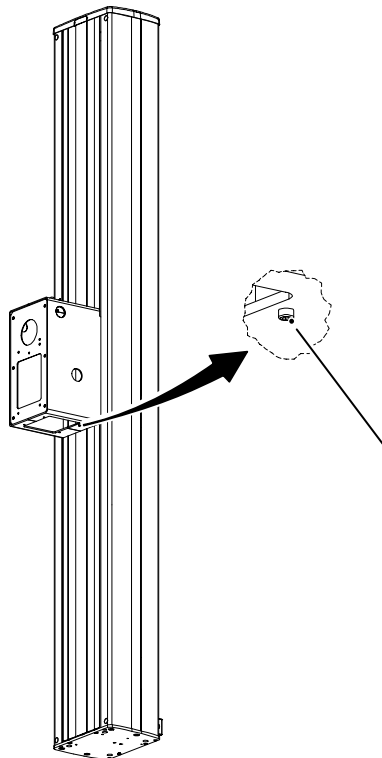

Fig. 4-112 Measuring point 2.CS

### 4.23.4 Protective Earth Wallstand

Measure the continuity between the measuring point 1.WS and the ground terminal 4,1PE01.



*Fig. 4-113 Measuring point 1.WS*

Measure at the earthing screw at the electrical plate.

Reconnect the earthing cable.

### 4.23.5 Protective Earth Table

Measure the continuity between the measuring point 1.TS and the ground terminal 4.1PE01.

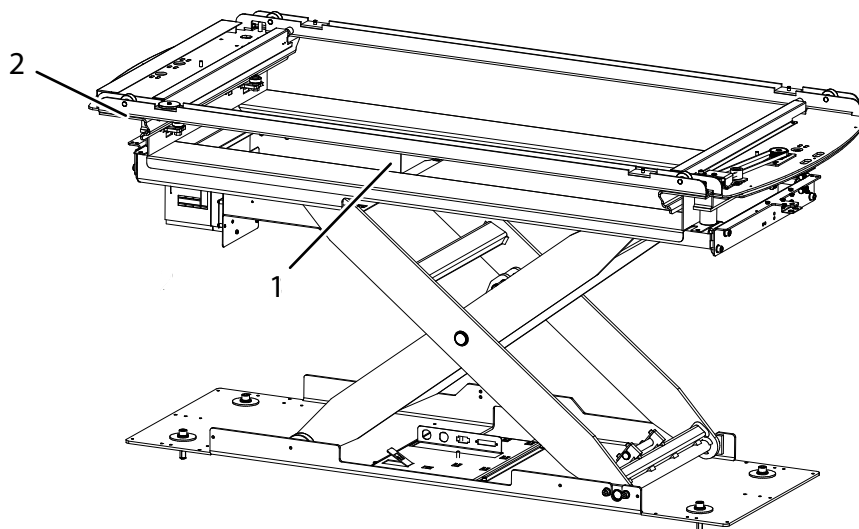

*Fig. 4-114 Measuring points, 1.TS, 2.TS*

1. Measuring point 1 (Detector holder wagon)
2. Measuring point 2 (Table frame wagon)

# Installation

## Alignment, Calibration and Adjustment

---

### 4.24 Alignment, Calibration and Adjustment

#### 4.24.1 Collimator Light- and X-ray Field Alignment

The collimator light field and the X-ray field are normally adjusted at delivery. However, the alignment must still be done at the installation.

1. Align the tube with the detector.
2. Attach some suitable objects on the detector holder cover. Position the objects within the active image receptor area, nearby the edges.
3. Perform an exposure and evaluate the alignment (images vs. the collimator light field) using the references applied in the previous step.
4. The maximum deviation between light field and X-ray field is  $\pm 1\%$  of SID, see figure below.
5. Adjust the collimator light field according to the collimator manual.

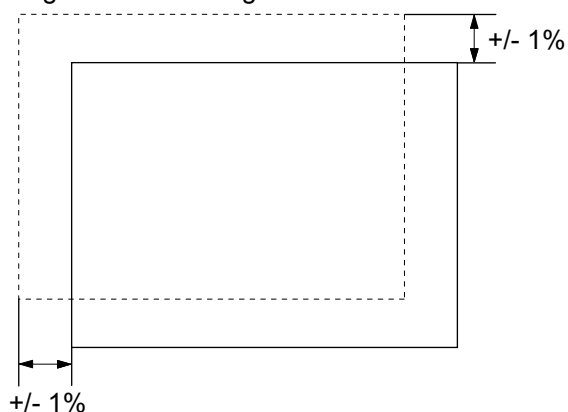

Fig. 4-115 Collimator light and X-ray field alignment

### 4.24.1.1 Adjustment of the Light Field

**Note!** \_\_\_\_\_

*Before starting adjusting, read the complete instruction.*

If the light field and the radiation field do not coincide adequately, use the two allen screws (1 and 2) on top of the collimator to center the light field, see Fig. 4-116 *Centering the light field*.

**Note!** \_\_\_\_\_

*The adjustment screws may only be turned until the resistance of the compression springs can be felt. The screws must not be loose!*

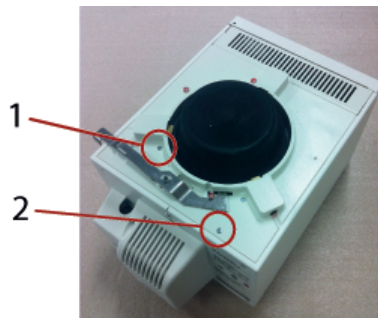

*Fig. 4-116 Centering the light field*

For HEIGHT ad- For moving the light field to the right, turn the screw (1) clockwise. For  
justment (X); moving the light field to the left, turn the screw (1) counterclockwise.

For WIDTH ad- For moving the light field backward, turn the screw (2) clockwise. For  
justment (Y); moving the light field forward, turn the screw (2) counterclockwise.

The adjustment range in the Y-direction is about three times larger than the X-direction range.

**CAUTION!** \_\_\_\_\_

***Do NOT, under any circumstances, loosen the slot-head screw (3) next to the two adjustment screws!***

# Installation

## Alignment, Calibration and Adjustment

---

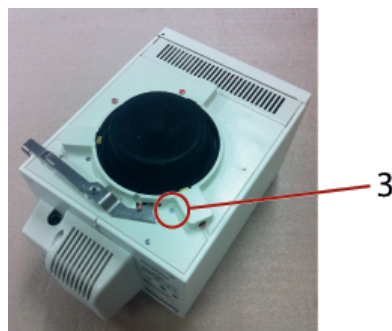

*Fig. 4-117 Do NOT touch!*

If needed, the cross-hairs window can be readjusted when the light field is adjusted.  
To readjust, loosen the 4 fastening screws at the holding frame and the line laser.

### 4.24.2 Correspondence Between X-ray Field and Image Reception Area

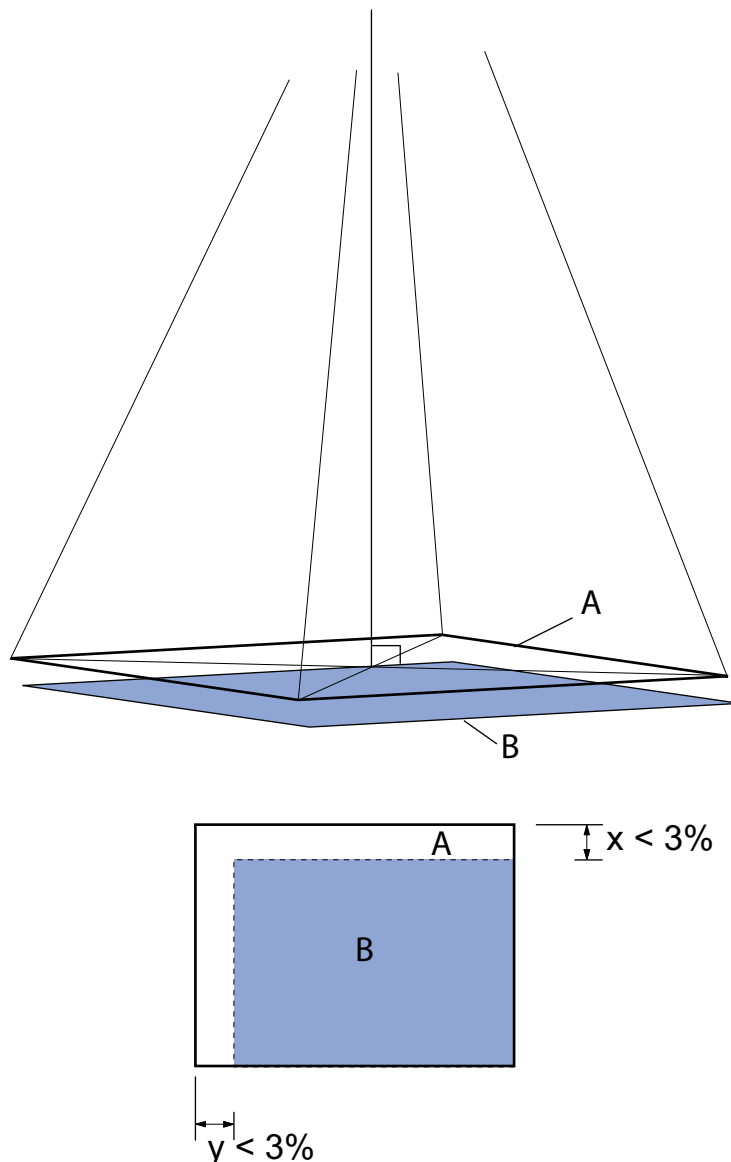

Fig. 4-118 X-ray field and Image reception area

1. Align the tube with the detector.
2. Perform an exposure and evaluate the alignment (images vs. the collimator light field) using the references applied in the previous step.
3. When the X-ray field (A) is adjusted in normal use for full coverage of the image reception area (B), it should correspond to the image reception area (B) within the following limits:

$$x < \text{SID} \times 0.03 \text{ OR } y < \text{SID} \times 0.03 \text{ AND } x + y < \text{SID} \times 0.04$$

See Fig. 4-118 X-ray field and Image reception area.

### 4.24.3 Calibration of System and Service Software

Calibrate the System and the Service Software.

# Installation

## Alignment, Calibration and Adjustment

### 4.24.4 Connections Image System Control PC

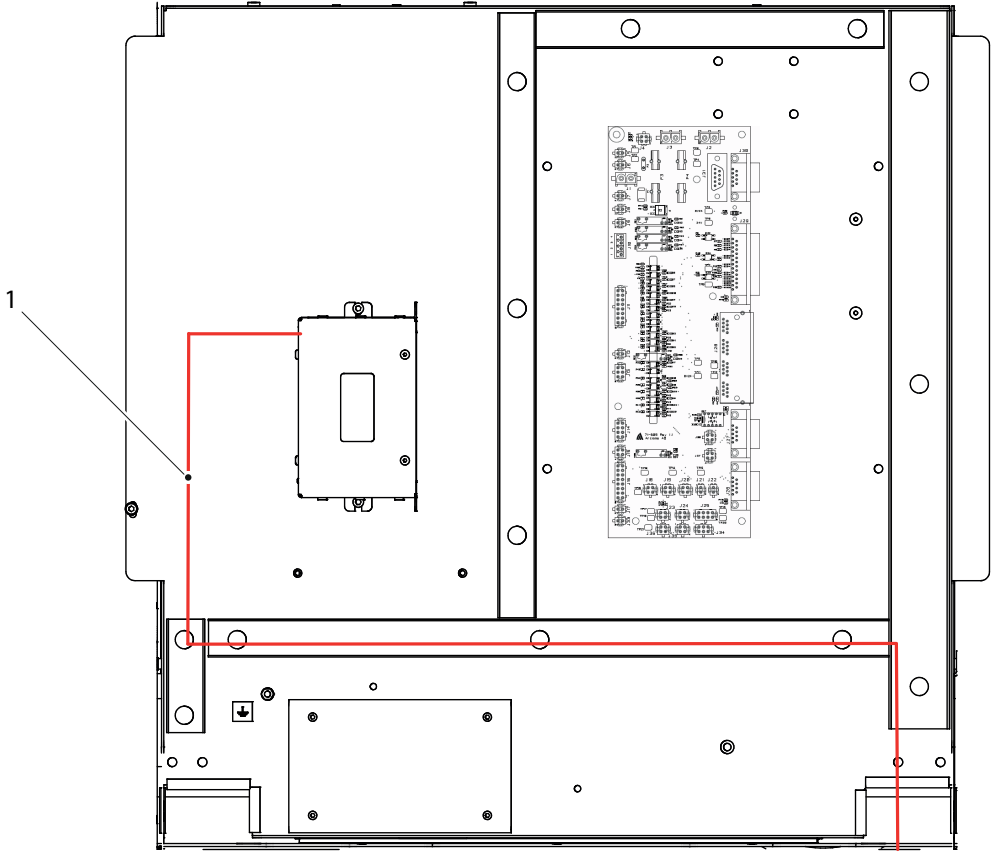

Fig. 4-119 Connecting the image system control PC (RS232)

- 1. Generator control board J3 — Image system control PC (RS232)



Fig. 4-120 Image system control PC (Ethernet)

- 1. System cabinet 4.4 CB800\_01 — J1 — Image system control PC (Ethernet)



### 4.24.5 Detector Calibration

For detector calibration, refer to Manufacturer's Detector Manual.

# Installation

## Alignment, Calibration and Adjustment

---

### 4.24.6 Connect OTC

#### 4.24.6.1 General

*Note!* \_\_\_\_\_

*A disconnecting device from the mains shall be incorporated external to the equipment according to the national wiring rules.*

---

Connect the OTC to the cabinet.

*Note!* \_\_\_\_\_

*The installation cables from the OTC must be installed covered. They shall not be placed on the floor.*

---

### 4.24.6.2 Install Positioning index

The positioning index is intended to be used to easily position the OTC in the center of the detector, over the Table, see Fig. 4-121 *Position index, Table*, or at the desired SID from the Wallstand, see Fig. 4-122 *Position index, Wallstand*.

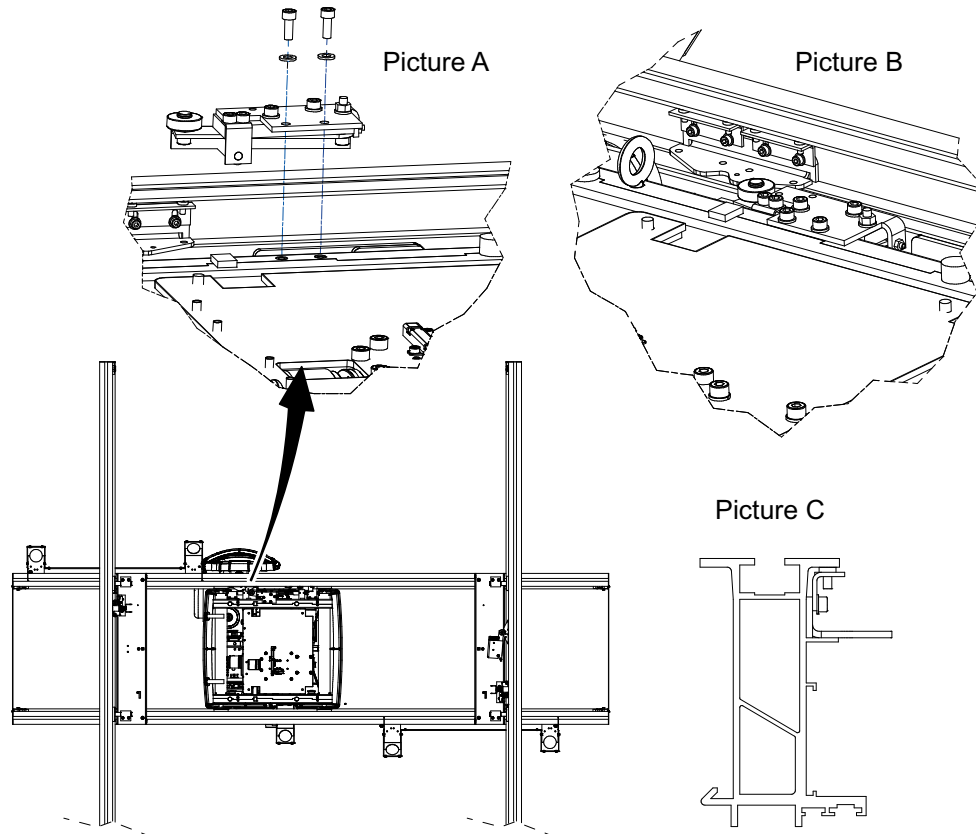

Fig. 4-121 *Position index, Table*

# Installation

## Alignment, Calibration and Adjustment

---

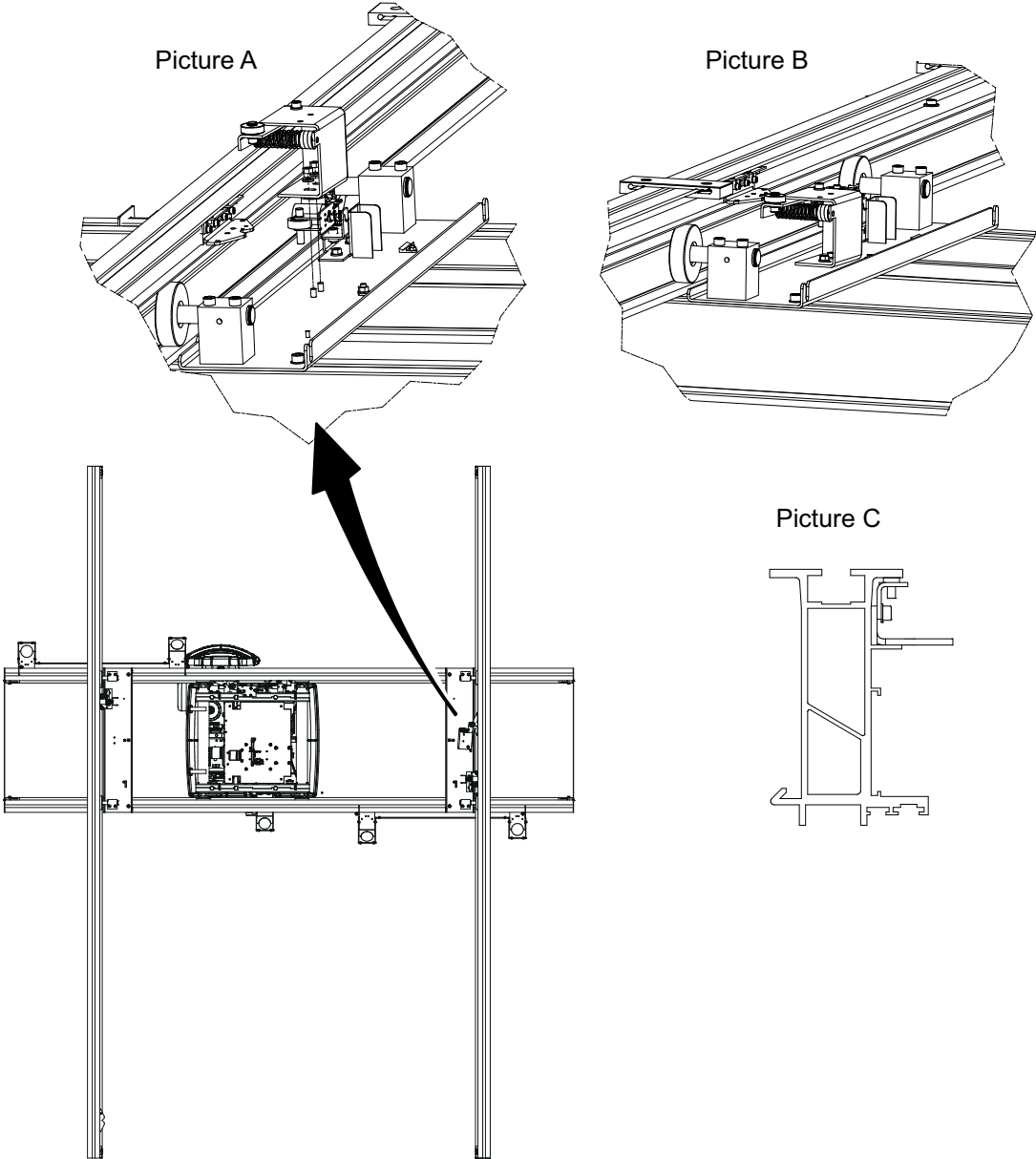

Fig. 4-122 Position index, Wallstand

# Installation

## Alignment, Calibration and Adjustment

To make it easier for the user to find the right SID from the Wallstand, use the enclosed stickers. Consult with the user and install the index(-es) at the desired SID and mark with the stickers according to Fig. 4-123 *Marking with stickers*.

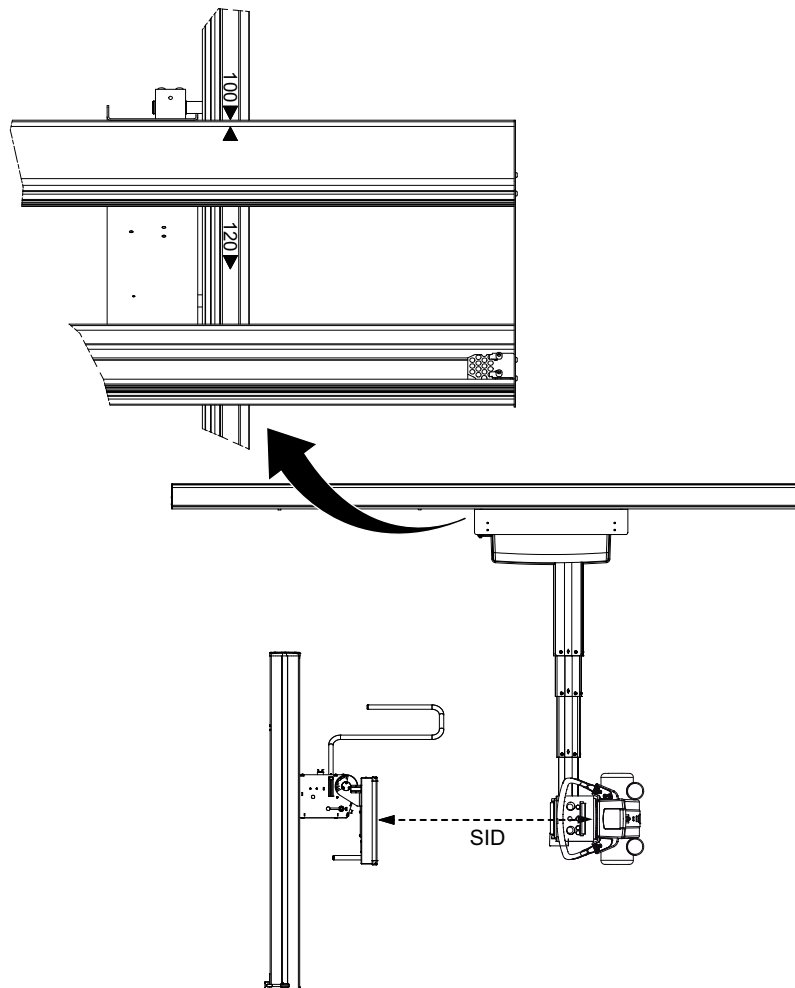

Fig. 4-123 *Marking with stickers*

# Installation

## Alignment, Calibration and Adjustment

---

### Micro Switch

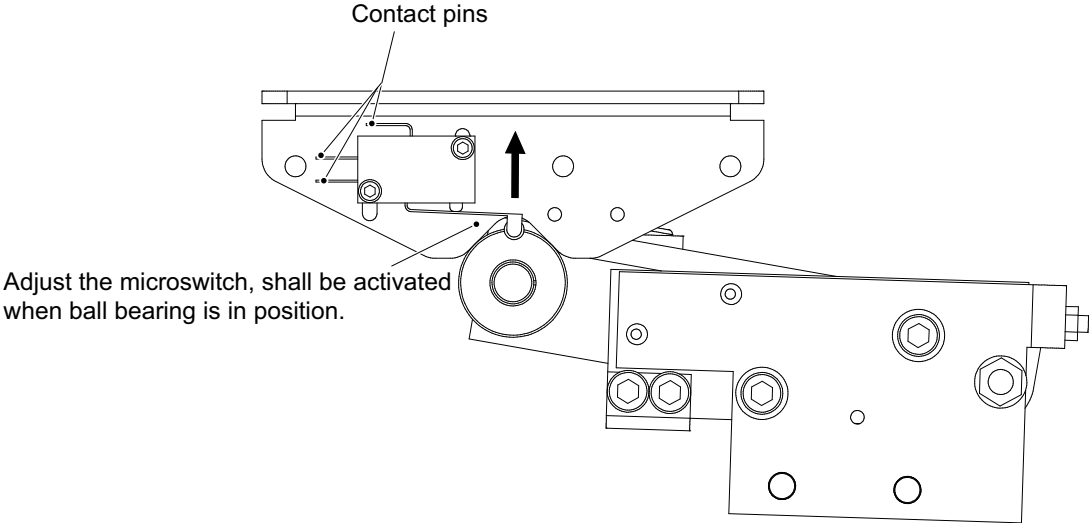

Fig. 4-124 Micro switch

The micro switch must be mounted in the arrow direction. It is important that the microswitch contact pins cannot touch moving parts during manual movement of the ceiling suspension in X/Y directions.

### Electrical Indexes

Connect the electrical indexes according to Fig. 4-125 *Connecting electrical indexes*

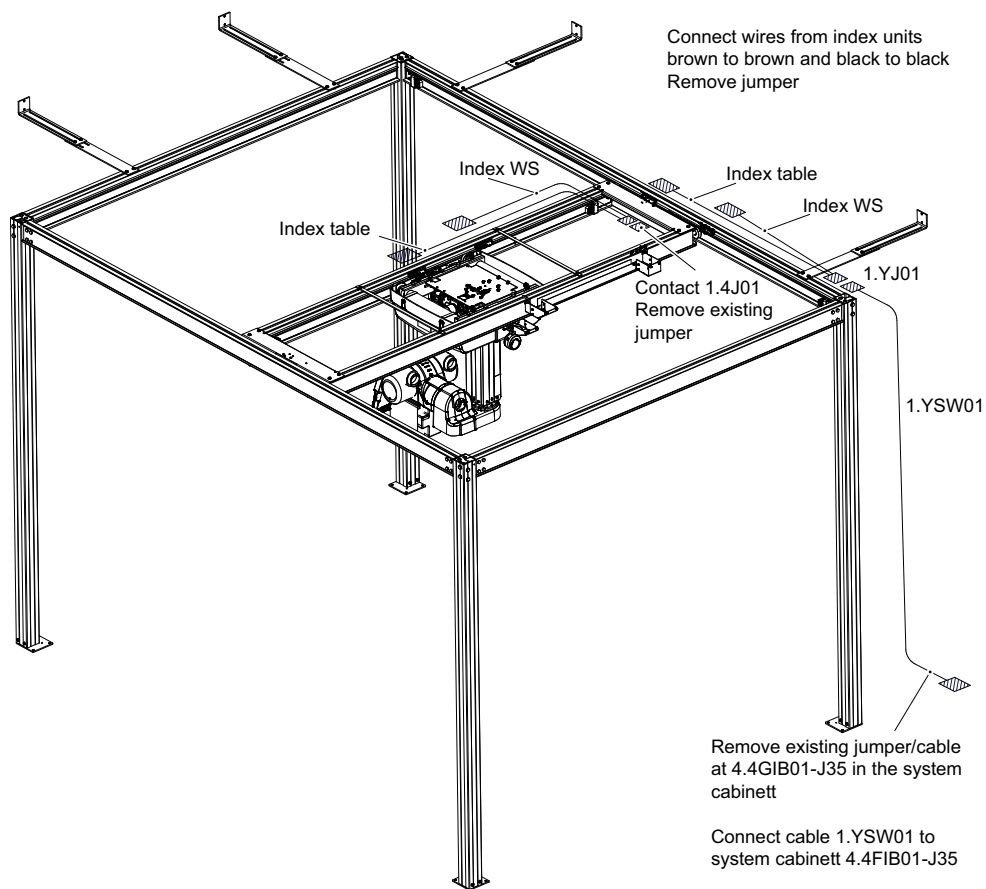

Fig. 4-125 *Connecting electrical indexes*

Check functionality of the electrical indexes.

X-ray exposure shall be inhibited when ceiling suspension is placed outside the index positions.

# Installation

## Alignment, Calibration and Adjustment

### 4.24.7 Calibration of OTC Movement

The movements of the OTC can be calibrated at the *SETTINGS* Menu, at the *SERVICE* view.

*Description:*

When folder *SERVICE* is selected, a numerical keyboard is shown to the user. A four digit access code is required.

At access, vertical folders are selectable for the full system.

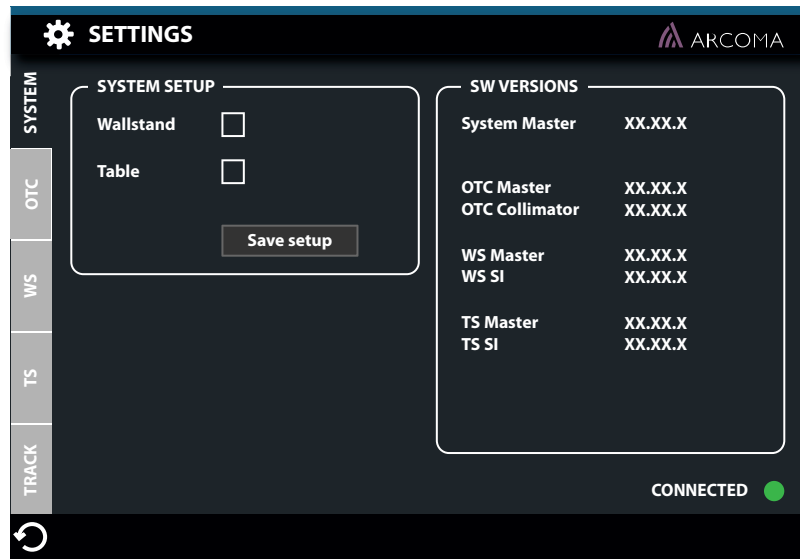



Fig. 4-126 Service tag selected

- *SYSTEM* - Always available.
- *OTC* - Always available.
- *WS* - Available when *WS* is selected in *SYSTEM* in the *SYSTEM SETUP*.
- *TS* - Available when *TS* is selected in *SYSTEM* in the *SYSTEM SETUP*.
- *TRACK* - Always available.

The activation of a button will result in:

-  a green check box, beside the button, if the value/change is accepted/defined.
-  a red cross, beside the button, if the value/change is not accepted/defined.

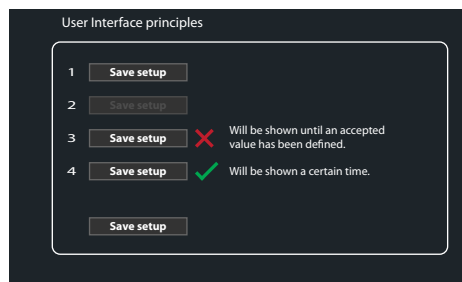

Fig. 4-127 Value/Change is accepted or denied



### 4.24.7.1 Z Position

#### **CAUTION!**

**When operating the column (Z-position) from the service program, software end stops are bypassed. Take great care when driving close to the end stop positions to prevent collisions.**

#### **Note!**

When recalibrating, perform all the steps below from 1 to 6.

Take the following actions:

1. Navigate in the menu to the “Z Position” view at *SERVICE/SETTINGS/OTC/Z CALIBRATION*.



Fig. 4-128 OTC view

2. Measure the focal spot to floor distance, preferably using the measuring tape in the collimator.
3. Enter the height at the “*Calibration position*” box. The height shall be entered in mm.

#### **Note!**

*Restart directly after each calibration to save the calibrated values.*

If it is a recalibration of the Z position, also perform the steps below.

4. Calibrate the Z high end stop, Z low end stop and Z safety zone.
5. Go to the *WS* resp. *TS* menus.
6. Recalibrate entering the values at *TS* “*Calibration position*” resp. *WS* “*Calibration position*”.

# Installation

## Alignment, Calibration and Adjustment

---

### 4.24.7.2 Z High End Stop

The correct position for setting the high end stop is approximately 20 mm below the mechanical end stop, which is placed in the column.

The distance can easiest be measured as in the figure below.

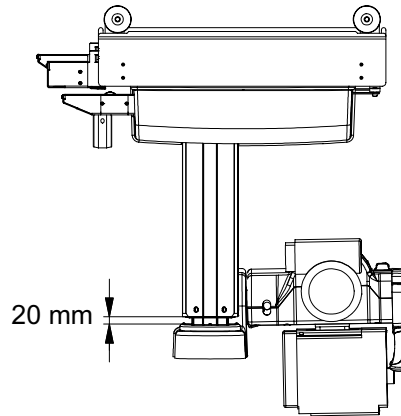

Fig. 4-129 High end stop

Take the following actions:

- Navigate to: *SERVICE/SETTINGS/OTC/End stops*.
- Select "Clear values". This enables to drive the OTC (Ceiling suspended tube support) to any position.
- Drive the OTC to the new desired position for the high end stop.

#### **Procedure to define the high end stop:**

When the OTC is in position, select "Set high" and the new position for high end stop is now defined. The position for the low end stop will remain the same.

- Restart directly after the calibration to save the calibrated values.

### 4.24.7.3 Z Low End Stop

For setting the Z low end stop, use the same procedure as for setting the definition of the high end stop.

But when the OTC is in the desired position for the low end stop, select “Set low” and the new position for low end stop is now defined. The position for the high end stop will remain the same.

Restart directly after the calibration to save the calibrated values.

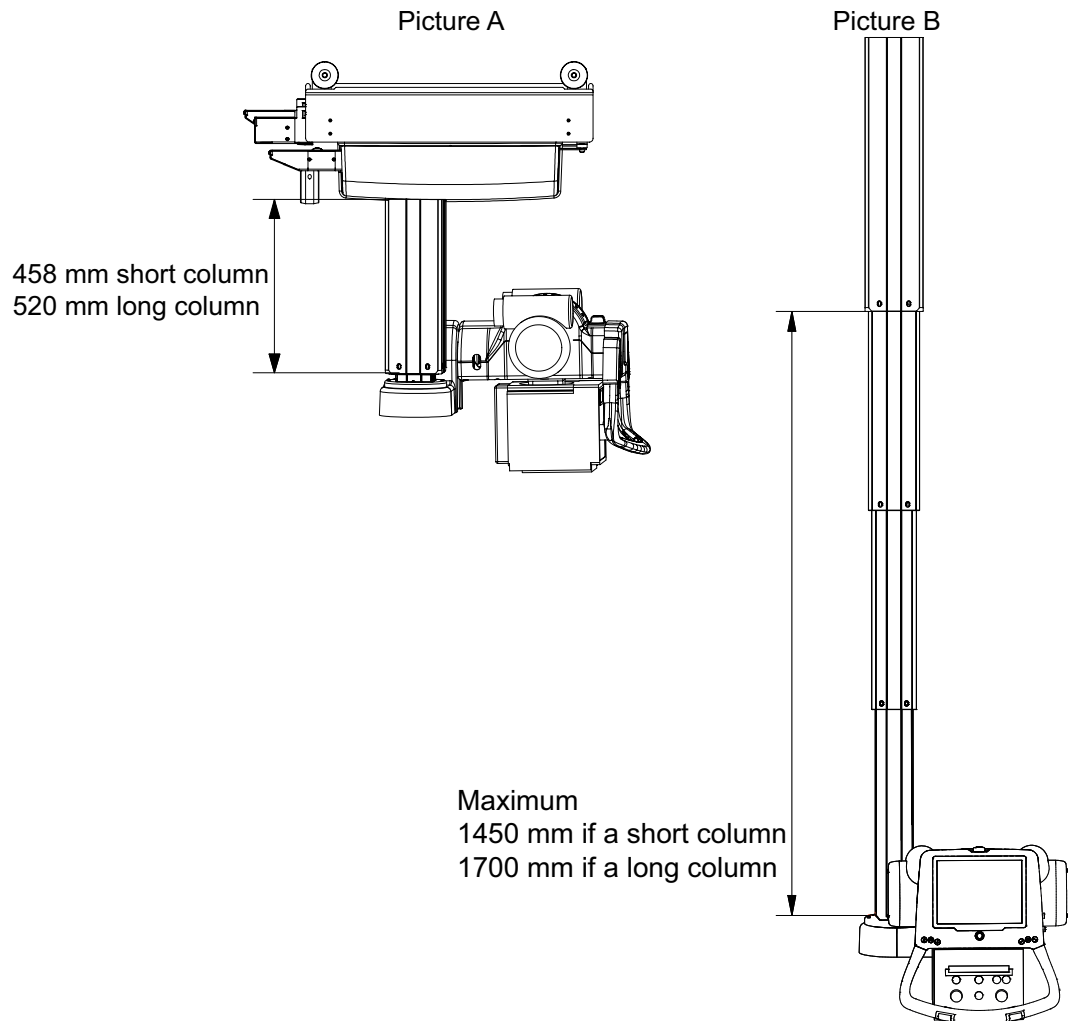

Fig. 4-130 Low end stop

# Installation

## Alignment, Calibration and Adjustment

### 4.24.7.4 Z Safety Zone

The correct position for calibrating the mechanical part of the Z safety zone is at a height of 1170 mm, from the floor to the lowest part of the OTC. The software safety zone is set at the same position. Make sure that the safety arm is not affected when setting the software safety zone.

Take the following actions:

1. Navigate in the *SERVICE/SETTINGS/OTC* menu to the *SAFETY HEIGHT* view.



Fig. 4-131 Safety Height

2. The correct position for calibrating the mechanical part of the Z safety zone, is at a height of 1170 mm, from the floor to the lowest part of the OTC. The software safety zone is set at the same position. Make sure that the safety arm is not affected when setting the software safety zone.

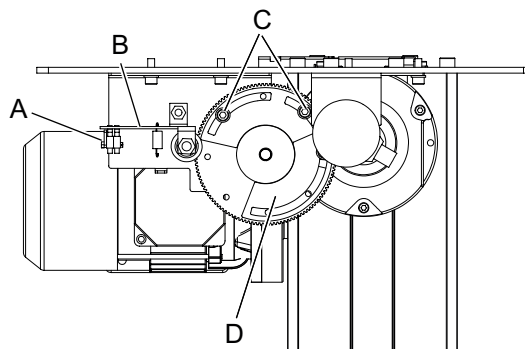
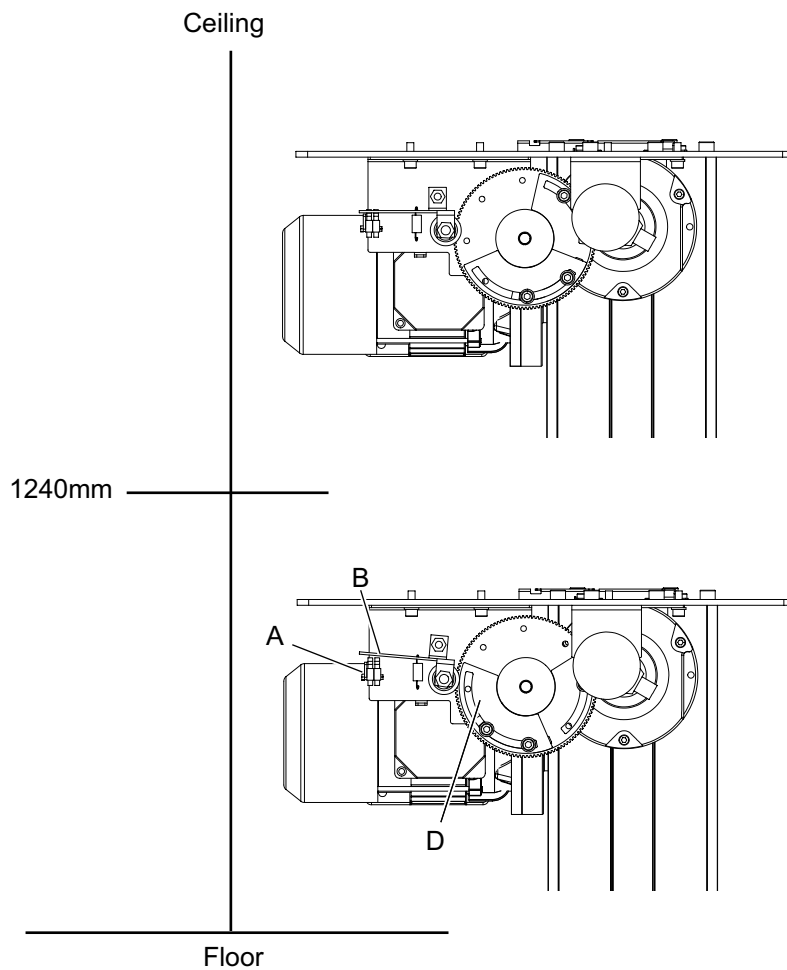

Fig. 4-132 Tilting lever

- |                 |          |
|-----------------|----------|
| A Switch        | C Screws |
| B Tilting lever | D Plate  |

3. Press the “*Save Safety height*” button to set the Z Safety zone.
4. Drive the column downward as low as possible. The tilting lever shall lift off the switches according to Fig. 4-133 *Setting Z safety zone*. If not, adjust the plates.
5. The correct position for calibrating the mechanical part of the Z safety zone, is at a height of 1170 mm from the floor to the lowest part of the OTC. The software safety zone is set at the same position. Make sure that the safety arm is not affected when setting the software safety zone.

6. Restart directly after the calibration to save the calibrated values.



*Fig. 4-133 Setting Z safety zone*

A Switch

B Tilting lever

C N/A

D Plate

# Installation

## Alignment, Calibration and Adjustment

### 4.24.7.5 Alpha Calibration

The calibration of Alpha requires two positions. The first position is with the alpha in 0° and the second with alpha in +90° clockwise.

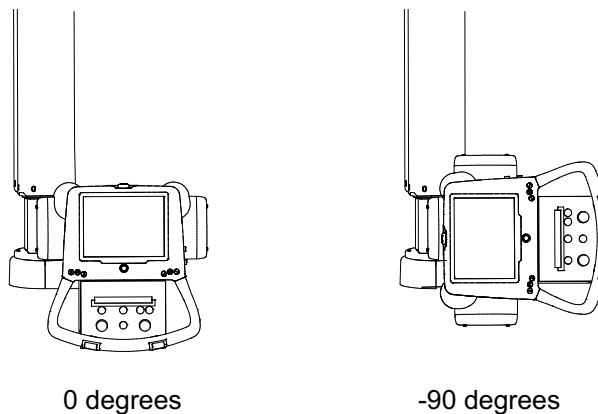

Fig. 4-134 Calibrating Alpha

Take the following actions:

1. Navigate in the *SERVICE/SETTINGS/OTC* menu to the *ALPHA CALIBRATION* view.



Fig. 4-135 Alpha calibration view

2. Release the alpha brake and turn alpha to 0°.
3. Press the *Set 0°*- button.
4. Release the alpha brake and turn alpha 90° counter clockwise.
5. Press the *Set 90°*- button.
6. Restart directly after the calibration to save the calibrated values.

### 4.24.7.6 TS Menu

Under this menu all movements of the Table stand can be calibrated. A requirement for all calibrations in this chapter is that the OTC calibration has been performed.

It is strongly advised to perform the resolution calibration for the table stand before doing the position calibration.



Fig. 4-136 Table stand view

#### Resolution Table

Calibration of the resolution requires two positions.

Take the following actions:

1. Navigate in the *SERVICE* menu to the *TS* view.
2. Move the Table to the lowest position, using the collimator light to point at the image plane (the surface of the detector) on the Table.

Position the OTC with the navigation buttons. See Fig. 4-137 *Highest Table position*.

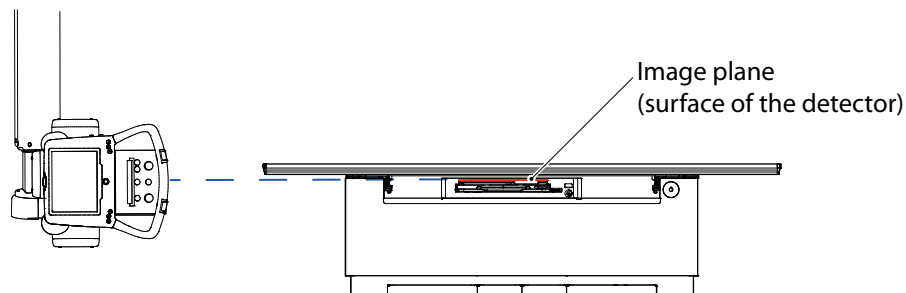

Fig. 4-137 Highest Table position

3. Press the *Set bottom-* button.
4. Move the Table to the highest position and point at the same spot as mentioned above. See Fig. 4-137 *Highest Table position*.
5. Press the *Set bottom-* button.
6. Restart directly after the calibration to save the calibrated values.

# Installation

## Alignment, Calibration and Adjustment

---

### *Position Table*

Take the following actions:

1. Navigate in the SERVICE menu to the *TS* view.
2. Measure the distance from the floor to the surface of the detector.
3. Enter the height at the "*Calibration position*" box. The height shall be entered in mm.
4. Restart directly after the calibration to save the calibrated values.



### 4.24.7.7 WS Menu

Under this menu all movements of the Wallstand can be calibrated. A requirement for all calibrations in this chapter is that the OTC calibration has been performed.

It is strongly advised to perform the resolution calibration for the Wallstand before doing the position calibration.



Fig. 4-138 Wallstand menu

# Installation

## Alignment, Calibration and Adjustment

---

### ***Resolution Wallstand***

Calibration of the resolution requires two positions.

Take the following actions:

1. Navigate in the SERVICE menu to the *WS/Z CALIBRATION* view.
2. Move the Wallstand to the lowest position. The Ceiling stand should be positioned against a spot on the Wallstand, preferably using the collimator to choose the position. Position the OTC with the navigation buttons. See Fig. 4-139 *Wallstand lowest position*.
3. Restart directly after the calibration to save the calibrated values.

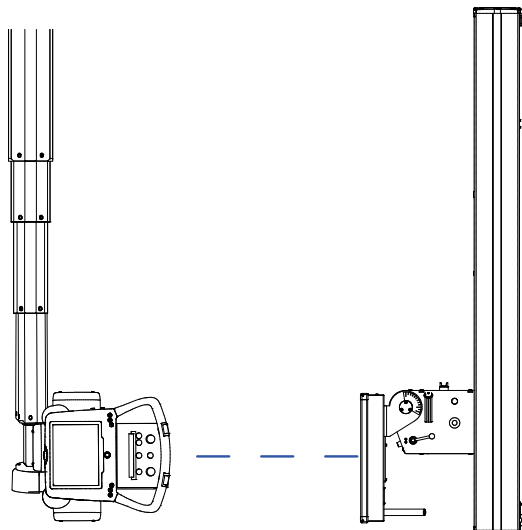

*Fig. 4-139 Wallstand lowest position*

4. Press the *Set bottom-* button.

# Installation

## Alignment, Calibration and Adjustment

---

5. Move the Wallstand to the highest position. Position the OTC against the same spot on the Wallstand by using the navigation buttons. See Fig. 4-140 *Wallstand highest position*.

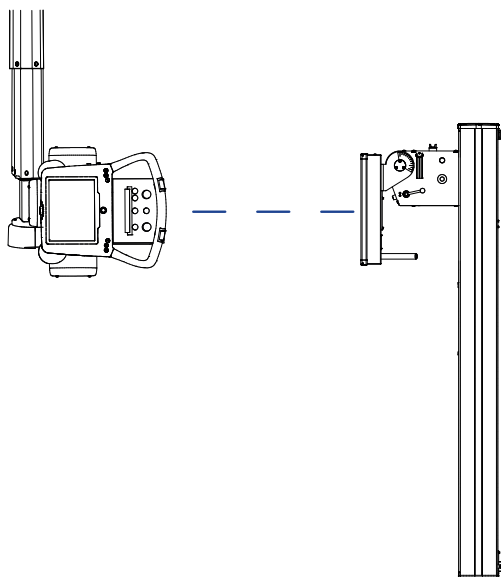

*Fig. 4-140 Wallstand highest position*

6. Press *Set top-* button.
7. Restart directly after the calibration to save the calibrated values.

# Installation

## Alignment, Calibration and Adjustment

---

### **Position Wallstand**

Take the following actions:

1. Navigate in the SERVICE menu to the *WS* view.
2. Measure from the floor to the center of the detector (picture A in figure below), or to the image plane (surface of the detector) if it is a tiltable detector (picture B in figure below).

**Picture A**

Image plane  
(center of the detector)

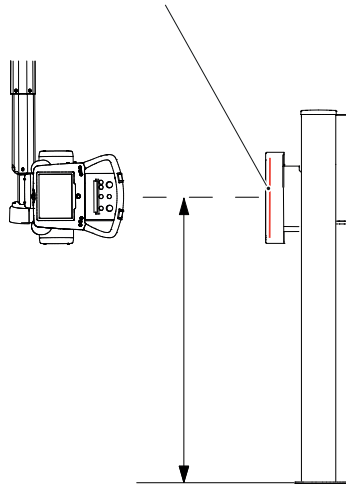

**Picture B**

Image plane  
(surface of the detector)

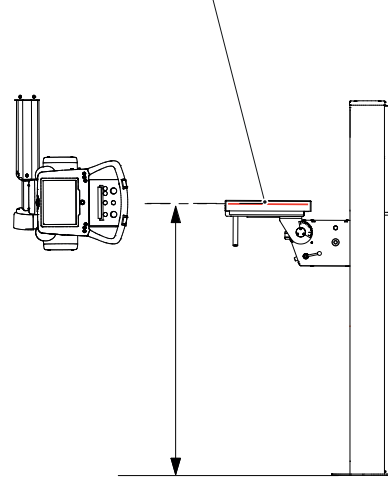

*Fig. 4-141 Measuring the height*

3. Enter the height at the “*Calibration position*” box. The height shall be entered in mm.
4. Restart directly after the calibration to save the calibrated values.

### 4.24.7.8 TS and WS Tracking

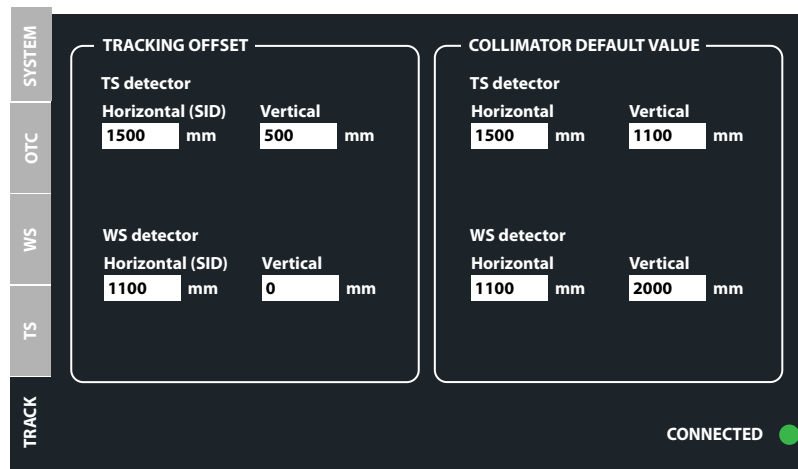

Fig. 4-142 Track menu

For setting the tracking offsets, navigate to *SERVICE/SETTINGS/TRACK* menu.

At the *TRACKING OFFSET* view, set the values for Table stand detector, resp. Wallstand detector. Enter both the horizontal (SID) and vertical values, in mm.

Enter the *COLLIMATOR DEFAULT VALUE* in mm.

Restart directly after the calibration to save the calibrated values.

# Installation

## Acceptance Tests

---

### 4.25 Acceptance Tests

*Note!*

*The generator is to be used by qualified persons having been trained in radiation protection.*

---

For further information of the installed X-ray tube, see the X-ray tube Data sheet.

#### 4.25.1 General

This section goes through the functional X-ray acceptance testing criteria that should be used to determine necessary compliance with the general performance requirements of the manufacturer.

It is not intended to prove conformance for all applicable regulatory requirements. The complete assessment of compliance regulatory as well as local/national requirements relies on the installer of the System.

For further acceptance test, please check the generator's Technical Manual and/or the relevant Standard(s).

##### 4.25.1.1 System Requirements

- Make sure the System is installed as described in *Installation in Chapter 4* of the Installation and Service Manual.
- Make sure the generator is setup, installed and calibrated as described in its Technical Manual.

##### 4.25.1.2 Terminology and Definitions

AEC	Automatic Exposure Control, in RAD mode. In an X-ray Generator, mode of operation in which one or more loading factors are controlled automatically in order to obtain at a preselected location a desired quantity of radiation.
kV	Peak voltage applied between the anode and cathode of an X-ray tube, in thousands of volts.
kW	Describes the product of both kV and mA output at the generator or loaded at the terminals of the X-ray tube.
mA	Average X-ray tube current, in milliAmperes, during the irradiation time. The operator console can also display the peak mA rather than the average mA, during the optional Pulsed Fluoro, if the user does want so.
mAs	X-ray tube current by time product (mA x Time), in milliamperes-seconds.
SID	Source to Image Distance
Time	Irradiation time, in milliseconds (ms) or seconds (s). Irradiation time represents the time interval between the instant that the tube potential has risen for the first time to a value of 80% and the instant at which it finally drops below the same value.

## 4.25.2 Peak Tube Potential

### 4.25.2.1 Test Equipment

Use the following calibrated measurement device:

- Non-invasive or invasive kV meters

### 4.25.2.2 kV Accuracy

Perform the following 3-points exposures (12) using the loading factors of Table 4-2 and verify the accuracy of the tube kV.

The error of the measured X-ray Tube Voltage of the different loading factors combination shall not be greater than  $\pm 10\%$ .

All tests must be passed for compliance.

Table 4-2

Set KV (kV)	Set mA (mA)	Set Time (ms)	Measured kV	Compliance criteria	Test passed	Test failed
60	50	100		60 +/- 10%		
60	100	100		60 +/- 10%		
60	250	100		60 +/- 10%		
80	50	100		80 +/- 10%		
80	100	100		80 +/- 10%		
80	250	100		80 +/- 10%		
100	50	100		100 +/- 10%		
100	100	100		100 +/- 10%		
100	250	100		100 +/- 10%		
120	50	100		120 +/- 10%		
120	100	100		120 +/- 10%		
120	250	100		120 +/- 10%		

# Installation

## Acceptance Tests

---

### 4.25.3 Tube Current

#### 4.25.3.1 Test Equipment

Use the following calibrated measurement device:

- mA/ mAs meter
- Oscilloscope



### 4.25.3.2 mA Accuracy

Perform the following 3-point exposures (12) using the loading factors of accuracy Table 4-3, and verify the accuracy of the tube current. The error of the measured X-ray Tube current of the different loading factors combinations shall not be greater than  $\pm 20\%$ .

All tests must be passed for compliance.

Table 4-3

Set KV (kV)	Set mA (mA)	Set Time (ms)	Measured mA	Compliance criteria	Test passed	Test failed
60	50	100		50 $\pm$ 20%		
60	100	100		100 $\pm$ 20%		
60	250	100		250 $\pm$ 20%		
80	50	100		50 $\pm$ 20%		
80	100	100		100 $\pm$ 20%		
80	250	100		250 $\pm$ 20%		
100	50	100		50 $\pm$ 20%		
100	100	100		100 $\pm$ 20%		
100	250	100		250 $\pm$ 20%		
120	50	100		50 $\pm$ 20%		
120	100	100		100 $\pm$ 20%		
120	250	100		250 $\pm$ 20%		

# Installation

## Acceptance Tests

### 4.25.4 Exposure Time

#### 4.25.4.1 Test Equipment

Use one of the following calibrated measurement device:

- Non-invasive or invasive kV meters
- mA/ mAs meter
- X-ray Dose meter

#### 4.25.4.2 Irradiation Time Accuracy

Perform the following 3-point exposures (12) using the loading factors of Table 4-4 and verify the accuracy of the irradiation time. The error of the measured irradiation time of the different loading factors combinations shall not be greater than  $\pm (10\% + 1 \text{ ms})$ .

All tests must be passed for compliance

Table 4-4

Set KV (kV)	Set mA (mA)	Set Time (ms)	Measured ms	Compliance criteria	Test passed	Test failed
60	50	100		100 +/- (10% + 1ms)		
60	100	100		100 +/- (10% + 1ms)		
60	250	100		100 +/- (10% + 1ms)		
80	50	100		100 +/- (10% + 1ms)		
80	100	100		100 +/- (10% + 1ms)		
80	250	100		100 +/- (10% + 1ms)		
100	50	100		100 +/- (10% + 1ms)		
100	100	100		100 +/- (10% + 1ms)		
100	250	100		100 +/- (10% + 1ms)		
120	50	100		100 +/- (10% + 1ms)		
120	100	100		100 +/- (10% + 1ms)		
120	250	100		100 +/- (10% + 1ms)		

### 4.25.5 Beam Quality

#### 4.25.5.1 Test Equipment

Use the following calibrated measurement device and material:

- X-ray dose meter.
- Non-invasive or invasive kV meters.
- 1100 aluminium with a purity of 99%.

Determine the HVL layer value at 4 different points. Use each of the following loading factors, see Table 4-5 . Compliance criteria is depending on the KV.

All tests must be passed for compliance.

Table 4-5

Set KV (kV)	Set mA (mA)	Set Time (ms)	Measured $\mu\text{Gy/mAs}$	Compliance criteria	Test passed	Test failed
120	50	100	X1	See above		
120	100	100	X2	See above		
120	250	100	X3	See above		

# Installation

## Acceptance Tests

---

### 4.25.6 Reproducibility

#### 4.25.6.1 Test Equipment

Use the following calibrated measurement device:

- X-ray dose meter

When you measure the reproducibility, expose several times on the same irradiation condition, and verify the reproductively with the exposed images. You also have to repeat the procedures for other irradiation conditions with some factors fixed.

Perform the following 3-point exposures (3) using the loading factors of and verify the dose ( $\mu\text{Gy}$ ). Compliance is achieved if the coefficient of variation between the average dose  $(X1 + X2 + X3)/3$  and every dose measurement  $X1, X2$  and  $X3 < 0.05$ .

All tests must be passed for compliance.

$$0.95 * (X1+X2+X3)/3 \leq X1 \leq 1.05 * (X1+X2+X3)/3$$

$$0.95 * (X1+X2+X3)/3 \leq X2 \leq 1.05 * (X1+X2+X3)/3$$

$$0.95 * (X1+X2+X3)/3 \leq X3 \leq 1.05 * (X1+X2+X3)/3$$

Table 4-6

Set KV (kV)	Set mA giving dose 1-5 $\mu\text{Gy}$	Set Time Between 10-320 ms	Measured $\mu\text{Gy}$	Compliance criteria	Test passed	Test failed
80	50	100	X1	See above		
80	100	100	X2	See above		
80	250	100	X3	See above		

## 4.25.7 AEC (Automatic Exposure Control)

Use the following test to demonstrate the constancy of the AEC mode.

### 4.25.7.1 Test Equipment

Use the following calibrated measurement device and material:

- X-ray Dose meter
- Plexiglas Phantom (or equivalent density)

In AEC mode, perform the following 3-point exposures (3) on every measuring field, using the loading factors and phantom sizes in Table 4-7 - Table 4-13 and measure the dose ( $\mu\text{Gy}$ ) \*1. We assume two chambers (Table and Wallstand), each having three measuring fields (Left, Center, Right).

Compliance is achieved if:

- The maximum dose error between two adjacent KV steps is between -15% and 18%. Example for 60 KV:
  - $-15\% \leq (1-(X1/X2)) * 100 \leq 18\%$
  - $-15\% \leq (1-(X1/X3)) * 100 \leq 18\%$
  - $-15\% \leq (1-(X2/X1)) * 100 \leq 18\%$
  - $-15\% \leq (1-(X2/X3)) * 100 \leq 18\%$
  - $-15\% \leq (1-(X3/X1)) * 100 \leq 18\%$
  - $-15\% \leq (1-(X3/X2)) * 100 \leq 18\%$
- The maximum dose error between any dose measurement and the mean of all dose measurements is between -20% and 25% (e.g. for 60 KV:  $-20\% \leq |1-(X1/(X1+X2+X3)/3)| * 100 \leq 25\%$ . Example for the Table Left field:
  - $-20\% \leq |1-(X1/(X1+X2+X3)/3)| * 100 \leq 25\%$
  - $-20\% \leq |1-(X2/(X1+X2+X3)/3)| * 100 \leq 25\%$
  - $-20\% \leq |1-(X3/(X1+X2+X3)/3)| * 100 \leq 25\%$

\*1: The 60601-2-54 § 203.6.3.2.102 standard defines the acceptance limits in optical density. To make production testing easier we have converted these optical density limits into the following dose limits:

Table 4-7

OD limit	Lower Dose limits	Upper Dose limits
$\pm 0.1$	-10.8%	+12.2%
$\pm 0.15$	-15.86%	+18.85%
$\pm 0.2$	-20.87%	+25.87%

# Installation

## Acceptance Tests

---

### 4.25.7.2 Table

Table 4-8

Set KV (kV)	Set mA (mA)	Phantom (cm)	Measured dose ( $\mu$ Gy)	Compliance criteria	Test passed	Test failed
60	100	10	X1	See above		
80	100	15	X2	See above		
100	100	20	X3	See above		

Left field

Table 4-9

Set KV (kV)	Set mA (mA)	Phantom (cm)	Measured dose ( $\mu$ Gy)	Compliance criteria	Test passed	Test failed
60	100	10	X1	See above		
80	100	15	X2	See above		
100	100	20	X3	See above		

Center field

Table 4-10

Set KV (kV)	Set mA (mA)	Phantom (cm)	Measured dose ( $\mu$ Gy)	Compliance criteria	Test passed	Test failed
60	100	10	X1	See above		
80	100	15	X2	See above		
100	100	20	X3	See above		

Right field

### 4.25.7.3 Wallstand

Table 4-11

Set KV (kV)	Set mA (mA)	Phantom (cm)	Measured dose ( $\mu$ Gy)	Compliance criteria	Test passed	Test failed
60	100	10	X1	See above		
80	100	15	X2	See above		
100	100	20	X3	See above		

Left field

Table 4-12

Set KV (kV)	Set mA (mA)	Phantom (cm)	Measured dose ( $\mu$ Gy)	Compliance criteria	Test passed	Test failed
60	100	10	X1	See above		
80	100	15	X2	See above		
100	100	20	X3	See above		

Center field

Table 4-13

Set KV (kV)	Set mA (mA)	Phantom (cm)	Measured dose ( $\mu$ Gy)	Compliance criteria	Test passed	Test failed
60	100	10	X1	See above		
80	100	15	X2	See above		
100	100	20	X3	See above		

Right field

# Installation

## Acceptance Tests

---



## 5 Maintenance

### 5.1 General



**WARNING!**

*Before working with service and maintenance that does not require power, always turn off the mains power breaker and make sure to lock it, so it cannot be mistakenly turned on.*

---



**WARNING!**

*Service to the System is restricted to authorized service representatives only. Attempts to service the System by unauthorized or unqualified personnel, could result in death, personnel injury or equipment damage, and will cease the equipment warranty.*

---



**WARNING!**

*Be aware of live parts when the covers are removed.*

---



**WARNING!**

*Squeezing hazard can occur between the vertical lift segments when moving in Z-direction.*

---



**WARNING!**

*Reduced safety when intentionally disabling of safety mechanism.*

---

**CAUTION!**

*Remaining energy may exist when the equipment is switched off. Always wait at least 15 seconds before working on the System.*

---

**CAUTION!**

*Be aware of possible squeezing hazards when the covers are removed.*

---

# Maintenance

## General

---

**CAUTION!**

*When the main unit power source breaker is turned OFF, the image receptor cannot be moved up or down using the brake release for Z-movement.*

*For safety reasons, however, the image receptor must be fixed to the main unit frame while the parts of the image receptor are being replaced.*

---

**CAUTION!**

*Electrical shock. Remaining voltage when System switch is turned off.*

---

**CAUTION!**

*Electrical shock. High leakage current due to stray currents.*

---

**CAUTION!**

*Use gloves when in contact with grease.*

---

**Note!**

*All main supply cables are only allowed to be changed by engineers trained by the supplier.*

---

**Note!**

*Before performing any maintenance, please read the Safety chapter.*

---

**Note!**

*For maintenance of components attached to the System (tube, generator, collimator etc.), refer to chapter 1 and System Documentation.*

---

This chapter contains the instructions necessary for maintaining the devices. This include:

- Alignments and settings
- Preventive maintenance
- Performance testing

To guarantee the safety of the patient and to ensure the functions and availability, the operator and third parties shall follow the instructions in this chapter.

Annual checks shall be performed either by local technical staff trained by the supplied or authorized service representatives. Daily and monthly checks are normally performed by the user/operator and is found in the Operator's Manual.

### 5.2 Software Version / Update

There are different software systems in the product.

1. Generator
2. Cabinet
3. Ceiling unit
4. Table
5. Wallstand

The software can be updated as described in the upgrade instructions, attached to the update document.

#### 5.2.1 The Software and Its Update Location Point

The software is physically located according to the Table below:

	System software	Connection point for software upload*	Upgrade instructions (UDI)
1.	Generator	See upgrade instruction	Upgrade_EMD_software
2.	Cabinet	See upgrade instruction.	SwUDI_0180-4C_x_y_z.pdf
3.	Ceiling unit	See upgrade instruction.	SwUDI_0170_x_y_z.pdf SwUDI_0180-4C_x_y_z.pdf
4.	Table	See upgrade instruction.	SwRLN_0181_x_y_z-.pdf SwUDI_0180-4C_x_y_z.pdf and SwRLN_0181_x_y_Z.pdf
5.	Wall stand	See upgrade instruction.	SwUDI_0180-4C_x_y_z.pdf

# Maintenance

## Function and Safety Checklist

---

### 5.3 Function and Safety Checklist

If any malfunction is detected, the entire equipment must be taken out of use until the malfunction is eliminated or usage of the System is approved by a service engineer from the supplier or by the local technical staff trained by the supplier.

Daily and monthly checks are normally performed by the user/operator.

Annual checks shall be performed either by local technical staff trained by the supplier or authorized service representatives.

The Manufacturer recommends use of the Checklist, Appendix B.

#### 5.3.1 Annual Checklist



#### **WARNING!**

---

##### ***Precautions for Supply Voltage.***

***A voltage of 400 to 480 VAC is supplied to the device. Observe the following points to protect yourself against receiving an electric shock;***

- ***Check that the device is securely grounded.***
- ***Check that all cables are connected correctly and free from damage.***
- ***Do not touch the parts of the cabinet while the LED (red) inside the Generator is ON. It may result in electric shocks due to remaining voltage.***

***Shut down the breaker of the facility and lock it.***

***Confirm the LED (red) is OFF before touching.***

- ***While performing work that requires the power supply to be turned ON, be careful not to touch the power line.***
- ***Even if the power is OFF, touching parts inside the device with the power cable plugged-in, may result in electric shocks.***

***Disconnect the power plug and wipe off dust and dirt with a dry cloth from time to time. Accumulated dust can generate heat and cause fires.***

---

##### 5.3.1.1 General

1. Cable terminals.

Remove the high voltage cable terminals and note whether corona or high voltage discharges have taken place.

Clean the receptacle and cable terminal and check for carbon tracks. (If carbon tracks are visible it will be necessary to replace the affected parts).

Recoat the cable terminal with dielectric component.

### 5.3.1.2 OTC

- 1. Turn on the collimator light and position the center of the collimator light field against a horizontal detector. Drive the column upward/downward. The center of the collimator light field must stay on the same spot. Check that the readouts for the tube angulation is 0°.
- 2. Perform the Alignment of OTC. Check that the readouts for the tube angulation is 90°.
- 3. Check the alignment of the light field and X-ray light field according to "Collimator light alignment", in Chapter 4.

### 5.3.1.3 0181 Table

**CAUTION!**

**Attach the safety clamp in maintenance position C.**

**Be sure that the attachment is well secured in the bottom plate.**

---

- 4. Check for abnormal sound.
- 5. Check for oil leaks.
- 6. Check for fallen foreign matter.
- 7. Check that the bolts that attach the Table to the floor are tightened properly. If there is evidence that the attachment to the floor has been damaged, order new bolts from the Manufacturer and reattach the Table to the floor.
- 8. Move the Table in X, Y and Z directions and make sure it runs smoothly and sounds OK.
- 9. Check the table top brakes:
  - Move the brakes in X or Y direction. The table top should run smoothly in X or Y direction whenever the brakes are released.
  - Lock the brakes and place a dynamometer against the table top and push slowly, it should be impossible to move the table top with a force under:
    - Y-direction < 300 N
    - X-direction < 250 N
  - When there is no power to the table top all brakes shall be applied.
  - Check the cables to the table top brakes.
- 10. Clean the profiles at the sides of the table top.
- 11. Clean the profiles for the image receptor tray movement (1).

# Maintenance

## Function and Safety Checklist

---

- 12. Check the installation of internal cabling underneath the covers.  
Check the cable ties and that the cables are in right position.  
The harness should go under the metal part in position A.
- 13. Check all internal and external cabling for damage. Squeezing and wear damages.
  
- 14. Check protective earth according to 4.23.2 *Measure Protective Earth*, Page 198. Enter the measured values in the Safety checklist Appendix B.
 

Measured value:	
.....	Ω
.....	Ω
.....	Ω
.....	Ω
  
- 15. Check status of critical circlips.
- 16. Check the screws of both mechanical end stops on the table top.  
If any screws are loose, tighten them.
- 17. Check both mechanical stops of the lifting unit. Feel if the clamp is loose, tighten if necessary.
  
- Remove safety clamp. Be careful, removed safety clamp — Squeezing hazard!
- 18. Lubricate the screw of the lifting unit with grease. Use grease *Klüber Duotempi PMY45*.  
Always order the grease from the manufacturer.  
To best get to the screw, drive the Table to the highest position. Use a brush to apply the grease.
- 19. Check both Emergency stop buttons on the Table. By activating the emergency stop all motorized movements are locked.
- 20. Check the vertical travel safety of the table top. Hold and restrain at the same time as moving the table top up or down. The travel safety will then stop the movement of the table top in the on going direction.
- 21. Check the function of the movements in X/Y/Z by pressing the buttons on all the controls. The buttons shall not be damaged or get stuck when they are pressed.

### 5.3.1.4 0055 Table

22. Check that the bolts fixing the Table to the floor, are properly tightened with 7 Nm (be careful the Loctite joint could break).

If any bolts are loose, use Loctite 243 and tighten with 15 Nm.

#### **Note!**

*This check is only valid when components from the Manufacturer have been used (i.e. valid expanders).*

23. Move the Table in X, Y and Z directions and make sure it runs smoothly and sounds OK.

24. Check the function of the table top brakes by moving it in X or Y direction.

The table top should run smoothly in X or Y direction whenever the brakes are released.

Lock the brakes and place a dynamometer against the table top and push slowly. It shall be impossible to move the table top with a force below  $\leq 200$  N.

Also check the cables to the table top brakes.

*If needed, adjust Y-brakes as follows:*

#### **Y-Brakes, adjustment**

Adjust by moving rail up and down.

This is the correct position.

The two parts has to be aligned to each other for best performance.

The wheel must be in contact with the brake plate all the time.

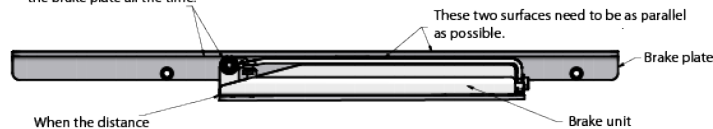

When the distance between the brake unit and the brake plate is correct - the spring underneath the brake unit will lift up the unit and a small gap will appear (approximately 1 mm) this will ensure the brake to work correctly.

Fig. 5-1

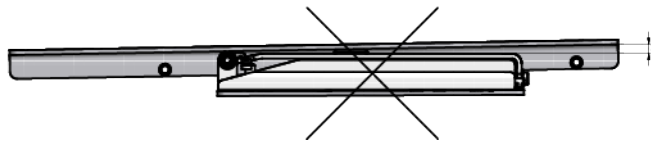

Fig. 5-2

# Maintenance

## Function and Safety Checklist

---

### Low Brake Force or Brake Release Problems.

If the distance is larger in the rear end than in the front, it will reduce the braking force. There will be a big risk that the brake unit will not release correctly and stock. This is due to the large distance between the magnets and the brake bar. Fig. 5-2

The same problem will appear, if the general distance between the brake unit and the brake plate is too large.

**Solution:** Align the brake unit and the brake plate when the magnets are active (i.e. the brake is released). Make sure there is a gap of approximately 1 mm underneath the brake unit.

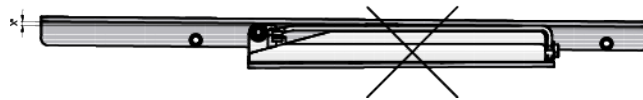

Fig. 5-3

### The Force Needed to Move the Table Top is Too Large.

If the distance is larger at the front than in the rear end, the table top will tend to jam when the brake unit is released.

The same problem will appear if the general distance between the brake unit and the brake plate is too small and the force on the wheel is too big.

**Solution:** Align the brake unit and the brake plate when the magnets are active (i.e. the brake is released). Make sure there is a gap of approximately 1 mm underneath the brake unit.

*If needed, adjust X-brakes as follows:*

### X-Brakes, Adjustment

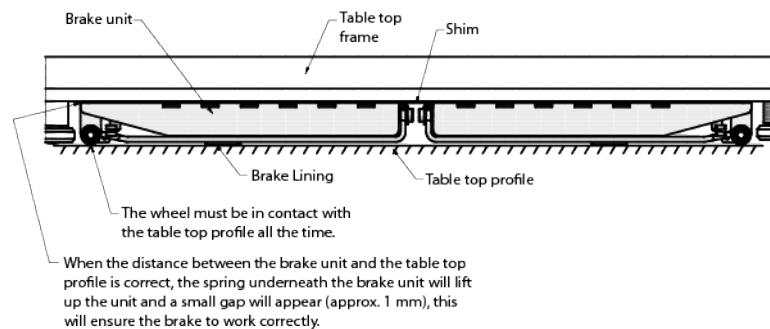

Fig. 5-4



### Low Brake Force and (or) Brake Release Problems.

If the distance is too large between the magnets and the brake bar, it will reduce the braking force and there is a risk that the brake unit will not release correctly, and stuck.

*Solution:* Add another shim, underneath the brake unit.

### The Force Needed to Move the Table Top is Too Large.

The table top tends to jam, when the brake unit is released.

The distance between the brake unit and the angle bar, is too small and the force on the wheel is too large.

*Solution:*

- *If the brake releases correctly* the distance between the brake unit and the table top profile is too small, remove shim from underneath the brake unit to increase the distance.
- *If the brake doesn't release correctly* the distance is too big then add shims to the brake unit.

25. Clean the profiles at the sides of the table top.

26. Clean the profiles for the imaging unit tray movement (1), according to figure

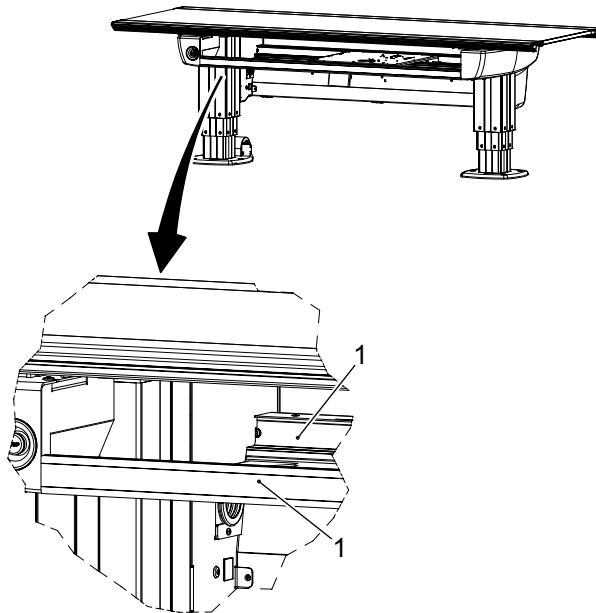

Fig. 5-5

27. Check the column segments on the Table (full stroke), they should run smooth and sounds OK. Lubricate the columns with BP Energol GR-XP 220, if necessary.

28. Check all cables for damage.

29. Check protective earth according to .

Enter the measured values in the Safety checklist Appendix B.

# Maintenance

## Function and Safety Checklist

---

30. Check the bolts of both mechanical end stops on the table top with 10 Nm.  
If any screws are loose, use Loctite 243 and tighten with 24 Nm. See figure.

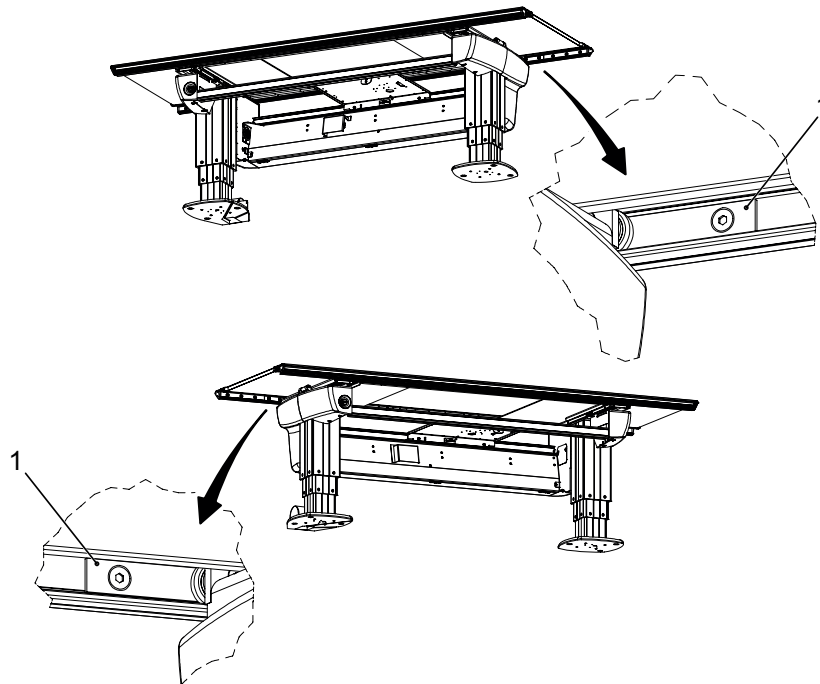
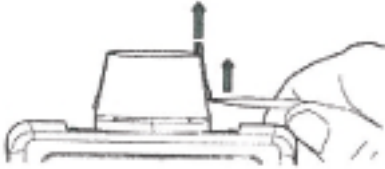



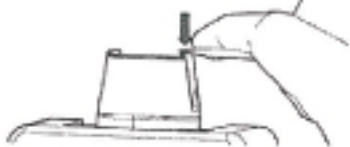

Fig. 5-6

31. Check the *Emergency stop* button on the Table. By activating the emergency stop all motorized movements are inhibited.
32. Check the guard function on the Table (if present). Hold and restrain at the same time as moving the table top up or down. The guard function will then stop the movement of the table top.
33. Check the buttons on the foot control, they shall not be damaged or get stuck when they are pressed.
34. Batteries in the wireless foot control (option), shall be changed at a minimum once a year. When changing the batteries, visually inspect the gasket for signs of degradation.

Table 5-1 Battery Replacement

<p>1 Remove the screw covers using a small flat bladed screwdriver or similar. Unscrew the lid.</p>	
<p>1 Release the battery clip hinge by firmly, but carefully, prising the clip posts outward.</p>	
<div style="display: flex; justify-content: space-around;">   </div>	
<p>1 Fit the batteries, taking care to observe the polarity as marked on the PCB. Push the clip back into place by holding the sides of the clip. Do <b>not</b> push on the antenna when clipping back into place.</p>	
<p>1 Screw the lid back into place- Press the screw covers back into place, using the flat part of the flat bladed screwdriver or alternatively. Loosely fit both covers. Press the whole assembly down onto a flat clean work surface.</p>	

35. Check the function of the AEC chamber, the Back up timer and the mAs. Calibrate if necessary.
36. Check the indication light, by choosing *Table flexible mode* on the generator console. Make sure the Table indication light is lit and that the display handle shows the corresponding mode.

### 5.3.1.5 Wallstand

1. Check for abnormal sound.
2. Check for fallen foreign matter.
3. Check that the bolts that fix the Wallstand to the floor are properly tightened with 7Nm (be careful the Loctite joint could break). If any bolts are loose, use Loctite 243 and tighten with 15Nm.
4. Check all cables for damage.
5. Clean all outer surfaces.
6. Make sure that the Operating Instructions are available.

# Maintenance

## Function and Safety Checklist

---

- 7. **Check lifting mechanism of Wallstand.**  
See 4.18.4 *Remove Back Cover*, Page 157.

**CAUTION!** \_\_\_\_\_  
**Secure the Wallstand with a locking device.**

---

There is no need to dismount the front cover.

- 8. The lift mechanism should be balanced and run smooth, without any sound.
- 9. Check the condition of the two lifting chains, the six chain locks and the attachment points of the chain, see Fig. 5-7 *Check points A and B*. Adjust if necessary.
- 10. Check the attachment points of the counterweights, see Fig. 4-67 *Loosen screws*.
- 11. Check the circlips (two) that secure the yoke to the axis. They should be in position, see Fig. 5-7 *Check points C*.
- 12. Check the mechanical end stops for the Z-movement.  
Check that they are intact and in position. There are four stops, two at the top and two at the bottom of the column.
- 13. Check the function of the brake. When the brake is released move the Wallstand up and down and the movement should stop.
- 14. Check protective earth according to 4.23.2 *Measure Protective Earth*, Page 198.  
Enter the measured values in the Safety checklist, Appendix B.

Measured value:  
..... Ω  
..... Ω

### 0175 Tilttable Wagon

- 15. Check the function of the gas springs for the tilt. The maximum force should be 50 Nm.
- 16. Check that the two mechanical end stops are intact. There are two stops located on the wagon.
- 17. Check the Emergency stop button on the Wallstand. By activating the emergency stop all motorized movements shall be inhibited. When the emergency stop is activated a message will be shown at the image display.

# Maintenance Function and Safety Checklist

---

### 5.3.1.6 Remark

No.	Remark	Action	Int note
1.	_____	_____	_____
2.	_____	_____	_____
3.	_____	_____	_____
4.	_____	_____	_____
5.	_____	_____	_____
6.	_____	_____	_____
7.	_____	_____	_____
8.	_____	_____	_____
9.	_____	_____	_____
10.	_____	_____	_____

# Maintenance

## Function and Safety Checklist

---

### 5.3.1.7 Check Points

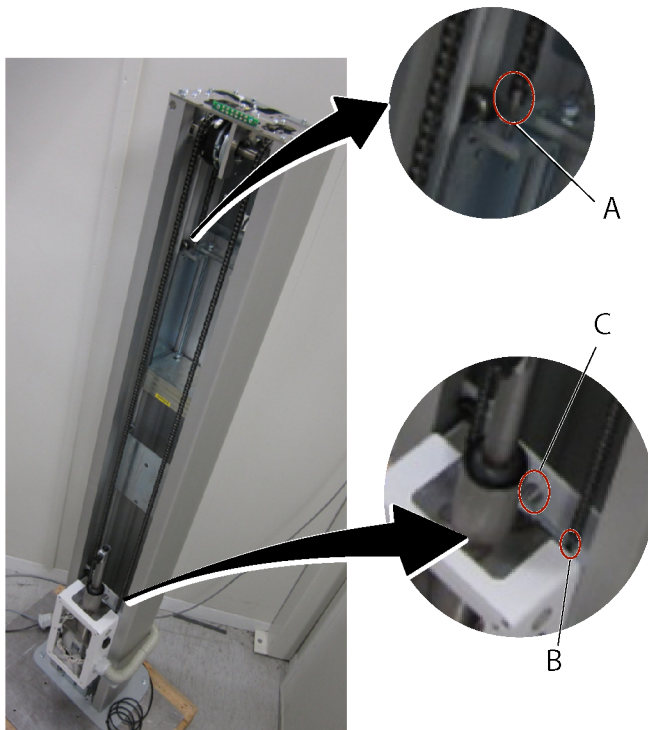

*Fig. 5-7 Check points*

- A 1 Chain lock on both chains
- B 2 Chain locks on both chains
- C 2 Circlips

## 6 Diagnostic

### 6.1 General

The OTC display will show error messages in case of fault.

#### 6.1.1 Fault Handling

There are three types of NOTIFICATIONS - Shows the present occurrence. For example; collision. They are listed below in ranking order.

1. ERROR — The error information appears as a red bar in the lower part of the display. Sound; two beeps.
2. WARNING - Appears as a grey bar in the lower part of the display. Sound; one beep.
3. INFO - Not shown to the user. Only registered in the setting menu.

##### 6.1.1.1 Notifications

###### - 1) Error

When an error occurs, an Error pop-up window will appear in the display.

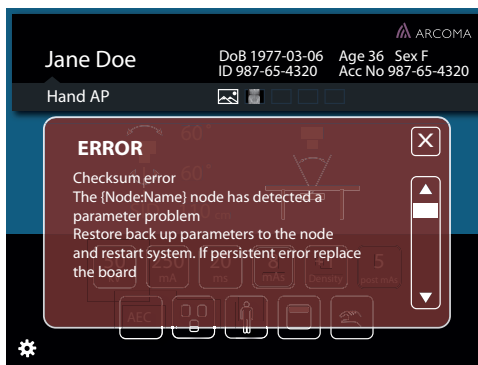

Fig. 6-1 Error pop-up window

The Error pop-up window will disappear when the user pushes the close button.



Fig. 6-2 Close button

# Diagnostic

## General

---

When closing the Error pop-up window (Fig. 6-1 *Error pop-up window*), a red information bar will appear (see Fig. 6-3 *Error information bar, Table* and Fig. 6-4 *Error information bar, Wall stand*).

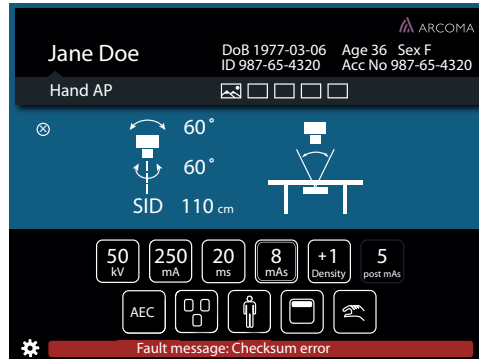

Fig. 6-3 *Error information bar, Table*

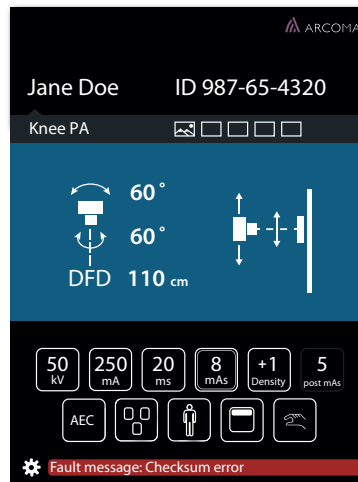

Fig. 6-4 *Error information bar, Wall stand*

When the user pushes the red information bar, the Error pop-up window will appear again. The Error information bar (lower part of the window) is present until the error is fixed or the System is restarted.



## 2) Warning

A warning message will appear in a Warning information bar (lower part of the display), when the handling of the System justifies that.

The Warning information bar will be cleared if/when a new warning is displayed, or after time.

The latest sent warning is shown.

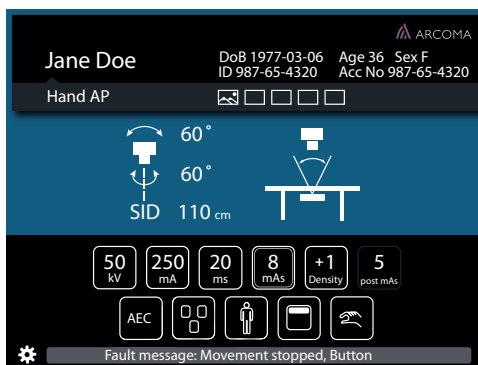

Fig. 6-5 Warning information bar, Table

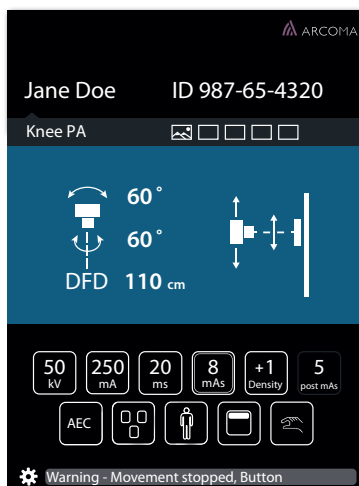

Fig. 6-6 Warning information bar, Wall stand

# Diagnostic

## General

---

When pushing the Warning information bar, (see Fig. 6-5 *Warning information bar, Table* and Fig. 6-6 *Warning information bar, Wall stand*), a pop-up window will appear (see Fig. 6-7 *Pop-up window — Warning information bar* and Fig. 6-8 *Pop-up window — Information bar*).

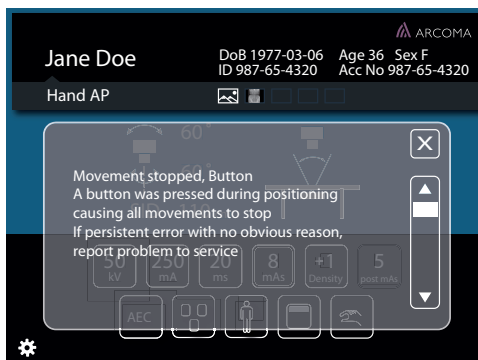

Fig. 6-7 Pop-up window — Warning information bar

When the user closes the pop-up window, the Warning Information bar will appear again. The Warning pop-up window will also appear again, when the user pushes the information bar.

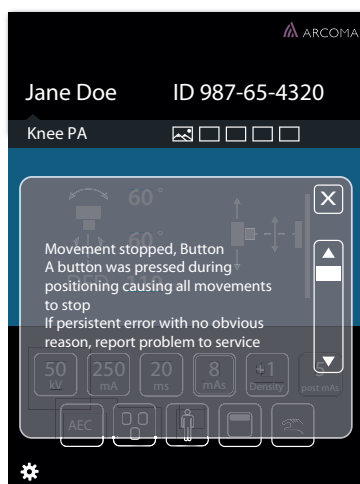

Fig. 6-8 Pop-up window — Information bar

The *Warning pop-up window* disappears when the user pushes the close button.



Fig. 6-9 Close button

### Log

The *Log file* is part of the *Setting menu* and reached by pressing the gear or the *Error/Warning messenger* bars.

## 6.2 System message two column table (option)

### 6.2.1 General

If the action says "Contact dealer" shall the entire error messages be noted and given to dealer.

That a valid System software release is used can be checked by the service software, the release should be shown in the lower right corner of the service software. It may also be checked by comparing the node and service software version shown in the service software with the versions stated in the RVL\_0055S\_SW document.

### 6.2.2 Description

A System message consists of the following parts, Type, Node, Component, Reason and Extra. Where:

- Type, defines the severity of the system message. This may be information, warning or error.
- Node, the node that sent the system message.
- Component, the component that caused the error.
- Reason, the cause of the message.
- Extra, four bytes of extra information. These bytes are always sent, even with messages that don't have any extra information. The extra information is shown as up to 4 parts, with the following format: <part number>:<description>< number of bytes used.>.

#### 6.2.2.1 Definitions

The following ids are used to identify the node in a system message.

##### *IDs used to identify the different nodes in a system message*

Node	Id
Master	1
Z1	2
Z2	3
Guard	4

# Diagnostic

## System message two column table (option)

---

### 6.2.3 All Nodes

#### 6.2.3.1 Component Id 01, Software Error

Reason	Description and status of System	Extra	Corrective action
01, Default error	Internal Software error.	N.a.	<ul style="list-style-type: none"><li>- Check that the correct parameter file is used.</li><li>- Check that a valid System software release is used.</li><li>- Contact dealer.</li></ul>
02, Error Value	Internal Software error.	N.a.	<ul style="list-style-type: none"><li>- Check that the correct parameter file is used.</li><li>- Check that a valid System software release is used.</li><li>- Contact dealer.</li></ul>

# Diagnostic

## System message two column table (option)

### 6.2.3.2 Component Id 02, Base Node

Reason	Description and status of System	Extra	Corrective action
01, Watchdog timeout	The node has detected that a watchdog was not received in time.	1: Component. 1 byte. 2: Time-out time in ms. 2 bytes.	- Check that all nodes are functional. - Check that the CAN bus cables are correctly connected.
02, Checksum error	The node has detected a checksum error in the parameter memory.	1: The calculated checksum. 1 byte. 2: Stored inverted checksum. 1 byte. 3: Stored checksum. 1 byte.	- Download the correct parameter file. - Change board.
03, Unknown command	The node has detected a CAN command that is not implemented in the node.	1: The unknown command. 1 byte. 2: Sender part of the CAN identifier. 2 bytes.	- Check that the correct parameter file is used. - Check that a valid System software release is used. - Contact dealer.
04, Logic power low	The node has detected that the logic power is low.	Not used.	- Check the 24 V logic voltage, measure at the logic power connector to the board.

# Diagnostic

## System message two column table (option)

---

### 6.2.4 Motor Nodes

#### 6.2.4.1 Definitions

The following collision types is defined.

Table 6-1 Description of the different collision types

Collision type	Description	Corrective action
1	Control error larger than specified by the "max position error" parameter.	<ul style="list-style-type: none"> <li>- Remove any blocking obstacle.</li> <li>- Check the mechanics.</li> <li>- Check that the correct parameter file is used.</li> </ul>
2	Time out, did not reach final position in time.	<ul style="list-style-type: none"> <li>- Remove any blocking obstacle.</li> <li>- Check the mechanics.</li> <li>- Check that the correct parameter file is used.</li> </ul>
3	No power, the power to the DC-board was switched off during a movement.	<ul style="list-style-type: none"> <li>- Check the 36V power voltage (measure at the power connector to the DC-board).</li> <li>- Check the DC-board fuse.</li> </ul>
4	Drive unit externally inhibited.	<ul style="list-style-type: none"> <li>- Check that the voltage between J3:2-J3:6 and J3:3-J3:6 (on the DC-boards) are zero volts.</li> </ul>
5	Position transducer has not moved, in spite that the output voltage has had an output voltage for a time. The voltage is specified in the "moved voltage" parameter and the time is specified in the "moved time" parameter.	<ul style="list-style-type: none"> <li>- Remove any blocking obstacle.</li> <li>- Check the mechanics.</li> <li>- Check that the correct parameter file is used.</li> <li>- Check the potentiometer.</li> </ul>

# Diagnostic

## System message two column table (option)

### 6.2.4.2 Component Id 03, Motor Node

Reason	Description and status of System	Extra	Corrective action
01, Transducer diff error	A motor node equipped with two position transducers, whose positions differs more than specified.	Not used.	<ul style="list-style-type: none"> <li>- Check that the correct parameter file is used.</li> <li>- Check the position transducers.</li> </ul>
02, Transducer not present	The position transducer is not connected to the node.	Not used.	<ul style="list-style-type: none"> <li>- Check that the correct parameter file is used.</li> <li>- Check the position transducer.</li> </ul>
03, Collision	A collision has occurred.	1: Collision type. 1 byte.	<ul style="list-style-type: none"> <li>- See table 6.1</li> </ul>
04, Encoder overflow	An encoder overflow has been detected.	Not used.	<ul style="list-style-type: none"> <li>- Check that the correct parameter file is used.</li> <li>- Check the encoder.</li> <li>- Contact dealer.</li> </ul>
05 Uncontrolled movement	An uncontrolled movement has been detected.	Not used.	<ul style="list-style-type: none"> <li>- Check if it was an actual movement or just a false position reading that caused the uncontrolled movement.</li> <li>- Check the potentiometer.</li> </ul>

# Diagnostic

## System message two column table (option)

### 6.2.4.3 Component Id 04, Driver Error

Reason	Description and status of System	Extra	Corrective action
01, Servo on error	Failed to perform a servo on	Not used.	- Check the 36V power voltage. - Check the DC-board fuse. - Check that the voltage between J3:2-J3:6 and J3:3-J3:6 (on the DC-boards) are zero volts.
02, Temperature error	Temperature of the driver is too high.	Not used.	- Let the DC-board cool off.
03, Shoot through error	Shoot through currents detected in the H-bridge of the driver.	Not used.	- Check for shortcuts in motor cabling and motor. Both between cables and toward chassis. - Change board.
04, Output current error	Error with the output current from the driver.	Not used.	- Check the 36V power voltage. - Check the DC-board fuse.
05, Output over voltage error	Error with the output voltage on the driver.	Not used.	- Check that the correct parameter file is used. - Contact dealer.
06, Driver watchdog error	A watchdog error from the driver was detected.	Not used.	- Check that the correct parameter file is used. - Contact dealer.
07, Communication error	Failed to communicate with the driver.	Not used.	- Check that the correct parameter file is used. - Contact dealer.
08, Motor error	Error with the motor detected.	Not used.	- Check that the correct parameter file is used. - Contact dealer.

### 6.2.4.4 Component Id3, CAN Driver Component

Reason	Description and status of System	Extra	Corrective action
N.a.			



# Diagnostic

## System message two column table (option)

---

### 6.2.4.5 Component Id 4, Timer Component

Reason	Description and status of System	Extra	Corrective action
N.a.			

### 6.2.4.6 Component Id 10, Communication Interface Component

Reason	Description and status of System	Extra	Corrective action
N.a.			

### 6.2.4.7 Component Id 11, ACAN Component

Reason	Description and status of System	Extra	Corrective action
01 Message not decoded	Internal software error.		<ul style="list-style-type: none"> <li>- Check that the correct parameter file is used.</li> <li>- Check that a valid System software release is used.</li> <li>- Contact dealer.</li> </ul>
02 Add node reason	Internal software error.	N.a	<ul style="list-style-type: none"> <li>- Check that the correct parameter file is used.</li> <li>- Check that a valid System software release is used.</li> <li>- Contact dealer.</li> </ul>
03 Bus off	CAN-bus error.	N.a	<ul style="list-style-type: none"> <li>- Check that the CAN bus cables are correctly connected.</li> <li>- Check that the CAN bus cables aren't damaged.</li> <li>- Change boards.</li> </ul>
04 Bus off not present	A previously reported CAN error has now been cleared.	N.a	

# Diagnostic

## System message two column table (option)

05 Error warning	CAN-bus error.	N.a	<ul style="list-style-type: none"> <li>- Check that the CAN bus cables are correctly connected.</li> <li>- Check that the CAN bus cables aren't damaged.</li> <li>- Change boards.</li> </ul>
06 Error warning not present	A previously reported CAN error has now been cleared.	N.a	
07 RX buffer overflow	Internal software error.	N.a	- Contact dealer.
08 SJA1000 data overrun	Internal software error.	N.a	- Contact dealer.
09 Transmit error	CAN-bus error.	N.a	<ul style="list-style-type: none"> <li>- Check that the CAN bus cables are correctly connected.</li> <li>- Check that the CAN bus cables aren't damaged.</li> </ul>
10 TX buffer overflow	Internal software error.	N.a	<ul style="list-style-type: none"> <li>- Check that the CAN bus cables are correctly connected.</li> <li>- Check that the CAN bus cables aren't damaged.</li> <li>- Contact dealer.</li> </ul>

### 6.2.4.8 Component Id 12, ASAP Component

Reason	Description and status of System	Extra	Corrective action
N.a.			

### 6.2.4.9 Component Id 13, Data Reader Component

Reason	Description and status of System	Extra	Corrective action
N.a.			

### 6.2.4.10 Component Id 20, JMATH Component

Reason	Description and status of System	Extra	Corrective action
N.a.			

# Diagnostic

## System message two column table (option)

---

### 6.2.4.11 Component Id 21, Linked List Component

Reason	Description and status of System	Extra	Corrective action
N.a.			

### 6.2.4.12 Component Id 30, Event Server Component

Reason	Description and status of System	Extra	Corrective action
01 Add event reason	Internal software error.	N.a	- Check that the correct parameter file is used. - Check that a valid System software release is used. - Contact dealer.

### 6.2.4.13 Component Id 31, Event Source Component

Reason	Description and status of System	Extra	Corrective action
N.a.			

### 6.2.4.14 Component Id 32, Client Manager Component

Reason	Description and status of System	Extra	Corrective action
01 Client id invalid	Internal software error.	N.a	- Check that the correct parameter file is used. - Check that a valid System software release is used. - Contact dealer.
02 Add client reason	Internal software error.	N.a	- Check that the correct parameter file is used. - Check that a valid System software release is used. - Contact dealer.

### 6.2.4.15 Component Id 33, Call Back Receiver Component

Reason	Description and status of System	Extra	Corrective action
N.a.			

# Diagnostic

## System message two column table (option)

---

### 6.2.4.16 Component Id 34, System Message Manager

Reason	Description and status of System	Extra	Corrective action
N.a.			

### 6.2.4.17 Component Id 35, Time Out Server Component

Reason	Description and status of System	Extra	Corrective action
N.a.			

### 6.2.4.18 Component Id 36, Memory Manager Component

Reason	Description and status of System	Extra	Corrective action
01 Memory exhausted	Internal software error.	N.a	<ul style="list-style-type: none"><li>- Check that the correct parameter file is used.</li><li>- Check that a valid System software release is used.</li><li>- Contact dealer.</li></ul>

### 6.2.4.19 Component Id 40, System Component

Reason	Description and status of System	Extra	Corrective action
N.a.			

### 6.2.4.20 Component Id 41, Master Component

Reason	Description and status of System	Extra	Corrective action
01 Enable nodes timeout	Internal software error.	N.a	<ul style="list-style-type: none"><li>- Check that the correct parameter file is used.</li><li>- Check that a valid System software release is used.</li><li>- Contact dealer.</li></ul>
02 Enable managers timeout	Internal software error.	1: Line number in the code. 4 bytes.	<ul style="list-style-type: none"><li>- Check that the correct parameter file is used.</li><li>- Check that a valid System software release is used.</li><li>- Contact dealer.</li></ul>

# Diagnostic

## System message two column table (option)

03 Unexpected disable node	Internal software error.	1: Line number in the code. 4 bytes.	<ul style="list-style-type: none"> <li>- Check that the correct parameter file is used.</li> <li>- Check that a valid System software release is used.</li> <li>- Contact dealer.</li> </ul>
04 Emergency stop	An emergency stop button was activated.	Not used.	<ul style="list-style-type: none"> <li>- Release emergency button.</li> </ul>
06 Event queue overflow	Internal software error.	N.a	<ul style="list-style-type: none"> <li>- Check that the correct parameter file is used.</li> <li>- Check that a valid System software release is used.</li> <li>- Contact dealer.</li> </ul>
08 Unknown node	Internal software error.	N.a	<ul style="list-style-type: none"> <li>- Check that the correct parameter file is used.</li> <li>- Check that a valid System software release is used.</li> <li>- Contact dealer.</li> </ul>

### 6.2.4.21 Component Id 42, Configuration Component

Reason	Description and status of System	Extra	Corrective action
01 Parameter checksum	An checksum error has been detected.	1: The calculated checksum. 1 byte. 2: Stored inverted checksum. 1 byte. 3: Stored checksum. 1 byte.	<ul style="list-style-type: none"> <li>- Download the correct parameter file.</li> <li>- Change board.</li> </ul>

# Diagnostic

## System message two column table (option)

---

### 6.2.4.22 Component Id 50, Movement Manager Component

Reason	Description and status of System	Extra	Corrective action
01 Add movement	Internal software error.	N.a	<ul style="list-style-type: none"><li>- Check that the correct parameter file is used.</li><li>- Check that a valid System software release is used.</li><li>- Contact dealer.</li></ul>
02 Unknown movement	Internal software error.	N.a	<ul style="list-style-type: none"><li>- Check that the correct parameter file is used.</li><li>- Check that a valid System software release is used.</li><li>- Contact dealer.</li></ul>

### 6.2.4.23 Component Id 51, Movement Component

Reason	Description and status of System	Extra	Corrective action
N.a.			

### 6.2.4.24 Component Id 54, Single Movement Component

Reason	Description and status of System	Extra	Corrective action
01 Start not allowed	A start of a movement was denied.	1: Start allowed result. 1 byte. 2: Movement direction. 1 byte. 3: Source id. 2 bytes, see tables at page 8-18.	<ul style="list-style-type: none"><li>- Check that the table top is leveled, this is checked by: Difference between Z1 and Z2 height (read in service software) should be less than 4 millimeters.</li><li>- Use the service software to check the angle given from the tilt sensor. If appropriate calibrate the tilt sensor.</li></ul>

# Diagnostic

## System message two column table (option)

### 6.2.4.25 Component Id 55, Auto-position Component

Reason	Description and status of System	Extra	Corrective action
01 Movement fail	A start of an auto position movement failed	1: Start allowed result. 1 byte. 2: Line number in the code. 3 bytes.	- Check that the table top is leveled, this is checked by: Difference between Z1 and Z2 height (read in service software) should be less than 4 millimeters. - Use the service software to check the angle given from the tilt sensor. If appropriate calibrate the tilt sensor.
02 All paused	Internal software error.	N.a	- Check that the correct parameter file is used. - Check that a valid System software release is used. - Contact dealer.

### 6.2.4.26 Component Id 56, Brake Movement Component

Reason	Description and status of System	Extra	Corrective action
01 Incorrect configuration	The brake movement was told to start a directional movement.	1: source id.4 byte.	- Check that a valid System software release is used. - Check the configuration.
02 Unlock brakes not allowed	It was not possible to unlock the brakes.	1: Start allowed result. 1 byte. 2: source id.3 bytes, see tables.	- Check that the table top is leveled. - Check the angle given from the tilt sensor.

# Diagnostic

## System message two column table (option)

### 6.2.4.27 Component Id 57, Double Movement Component

Reason	Description and status of System	Extra	Corrective action
01 Start not allowed	A start of a movement was denied.	1: Start allowed result. 1 byte. 2: Movement direction. 1 byte. 3: Source id. 2 bytes (see tables).	- Check that the table top is leveled, this is checked by: Difference between Z1 and Z2 height (read in service software) should be less than 4 millimeters. - Use the service software to check the angle given from the tilt sensor. If appropriate calibrate the tilt sensor.
02 End set point timeout	Internal software error.	Not used.	- Contact dealer.

### 6.2.4.28 Component Id 70, Supervisor Component

Reason	Description and status of System	Extra	Corrective action
01 Table top alignment error	The table top is not level.	1: Height difference between Z1 and Z2, in 0.1 mm. 4 bytes	- Press foot pedal until table top is leveled; this may require that the pedal is pressed more than once.
02 Tilt sensor full movement	The tilt sensor does not prevent any movement.	1: Table top angle (0.01°), given from the tilt sensor. 4 bytes.	
03 Tilt sensor restricted angle	The tilt sensor does prevent movement.	1: Table top angle (0.01°), given from the tilt sensor. 4 bytes.	- Press foot pedal until table top is leveled; this may require that the pedal is pressed more than once.  - If table top is leveled (measure with water level) calibrate the tilt sensor.
04 Guard crash detected	The guard board has detected a crash.	1: Crash direction, 1 for a positive crash and 2 for a negative crash. 1 byte.	- Remove obstacle.



# Diagnostic

## System message two column table (option)

### 6.2.4.29 Component Id 80, Node Component

Reason	Description and status of System	Extra	Corrective action
01 Message decode	Internal software error.	N.a	<ul style="list-style-type: none"> <li>- Check that the correct parameter file is used.</li> <li>- Check that a valid System software release is used.</li> <li>- Contact dealer.</li> </ul>
02 Communication not established	Internal software error.	N.a	<ul style="list-style-type: none"> <li>- Check that the correct parameter file is used.</li> <li>- Check that a valid System software release is used.</li> <li>- Contact dealer.</li> </ul>

### 6.2.4.30 Component Id 81, Slave Node Component

Reason	Description and status of System	Extra	Corrective action
01 watchdog timeout	A watchdog timeout occurred.	1: Source id. 1 byte. 2: Line number in the code. 2 bytes.	<ul style="list-style-type: none"> <li>- Check the state of the node (shown I service software).</li> <li>- Check the LED's on the board (for error indication).</li> </ul>
02 Unexpected node state	Internal software error.	N.a	<ul style="list-style-type: none"> <li>- Check that the correct parameter file is used.</li> <li>- Check that a valid System software release is used.</li> <li>- Contact dealer.</li> </ul>
03 Set state failed	Internal software error.	N.a	<ul style="list-style-type: none"> <li>- Check that the correct parameter file is used.</li> <li>- Check that a valid System software release is used.</li> <li>- Contact dealer.</li> </ul>
04 Acknowledge status	Internal software error.	N.a	<ul style="list-style-type: none"> <li>- Check that the correct parameter file is used.</li> <li>- Check that a valid System software release is used.</li> <li>- Contact dealer.</li> </ul>

# Diagnostic

## System message two column table (option)

05 Init timeout	Internal software error.	N.a	- Check that the correct parameter file is used. - Check that a valid System software release is used. - Contact dealer.
06 Node ready	Internal software error.	N.a	- Check that the correct parameter file is used. - Check that a valid System software release is used. - Contact dealer.

### 6.2.4.31 Component Id 82, Motor Component

Reason	Description and status of System	Extra	Corrective action
N.a.			

### 6.2.4.32 Component Id 83, Guard Component

Reason	Description and status of System	Extra	Corrective action
N.a.			

### 6.2.4.33 Component Id 90, Foot Pedal Component

Reason	Description and status of System	Extra	Corrective action
01 Switch active at start up	A pedal was active at start up.	1: Current foot pedal input status. 4 bytes. The following masks are used: Z up 0x0000 0001 Z down 0x0000 0002 X brake 0x0000 0004 Y brake 0x0000 0008 XY brake 0x0000 0200 DMG 0x0000 0100	- Check foot pedal.

# Diagnostic

## System message two column table (option)

01 Switch active at start up	The time between activation/deactivation of the Z up/down and the dmg switch was too large.	Not used.	- Check foot pedal.
03 Switch function deactivated	The activated switch functionality was deactivated.	Not used.	- Some earlier error caused that this function has been deactivated.

### 6.2.4.34 Component Id 91, Tilt Sensor Component

Reason	Description and status of System	Extra	Corrective action
N.a.			

### 6.2.4.35 Component Id 93, Emergency Switch Component

Reason	Description and status of System	Extra	Corrective action
01 Switch active at start up	An emergency switch was active at start up.	1: Current emergency switch input status. 4 bytes. The following masks are used: Internal 0x00000400 External 0x00000800	- Check the emergency switches.
02 Internal emergency switch is activated	The internal emergency switch was activated.	Not used.	
03 External emergency switch is activated	The external emergency switch was activated.	Not used.	
04 Emergency switch released	The last emergency switch was deactivated.	Not used.	

### 6.2.4.36 Component Id 94, ASAP Client Component

Reason	Description and status of System	Extra	Corrective action
N.a.			

# Diagnostic

## System message two column table (option)

---

### 6.2.5 Master Node

#### 6.2.5.1 Definitions

The information in the tables below refer to the notes in the column “Extra” in the tables above.

*Table 6-2 IDs used to identify the movements.*

<b>Movement ID</b>	<b>Number</b>	<b>Description</b>
Z1 movement	0	Z1 column
Z2 movement	1	Z2 column
Table top x movement	2	Table top X-direction
Table top y movement	3	Table top Y-direction
Table top movement	16	Table top Z-direction
Auto-position movement	32	Auto-positioning table top Z-direction

*Table 6-3 IDs used to identify the different parts within the master.*

<b>Source ID</b>	<b>ID</b>
None	0
Internal	1
Supervisor	2
System	3
Master	4
Movement manager	10
Movement Z1	11
Movement Z2	12
Movement table top X	13
Movement table top Y	14
Movement table top	15
Movement auto-position	16
System message manager	30
Motor Z1	40
Motor Z2	41
Guard	42
Foot pedal	50
Emergency switch	51

# Diagnostic

## System message two column table (option)

---

Tilt sensor	52
CLI handler	60
ACAN client	61

*Table 6-4 IDs used to identify the different start allowed results.*

<b>Movement</b>	<b>Number</b>	<b>Description</b>
OK	0	Ok to start.
Supervisor not enabled	1	
Auto-position already started	2	
Tilted	3	Table top not level.
Crash	4	Guard crash active.
Error	5	An error has occurred.

*Table 6-5 IDs used to identify the different movement directions.*

<b>Movement</b>	<b>Number</b>	<b>Description</b>
No direction	0	Ok to start.
Positive direction	1	
Negative direction	2	
Unknown direction	3	Table top not level.

# Diagnostic

## System message two column table (option)

---

## 7 Electrical drawings

7.1	Notes regarding the electrical drawings	279
7.2	System block diagram (4C valid for Omnera 400T)	281
7.2.1	System	281
7.2.1.1	0180 System C	281
7.2.2	Image system	283
7.2.2.1	Image system C	283
7.2.2.2	CXDI TS 401 or 701C Wireless and WS 401 or 701C Wireless	285
7.2.2.3	CXDI TS 401 or 701C Wireless and WS 401 or 701C Wireless with charging	287
7.2.2.4	CXDI TS 401 or 701C Wireless and WS 401 compact	289
7.2.2.5	CXDI TS 401 or 701C Wireless with charging and WS 401 or 701C Wireless	291
7.2.2.6	CXDI TS 401 or 701C Wireless with charging and WS 401 or 701C Wireless with charging	293
7.2.2.7	CXDI TS 401 or 701C Wireless with charging and WS 401 compact	295
7.2.2.8	CXDI TS 401 compact and WS 401 or 701C Wireless	297
7.2.2.9	CXDI TS 401 compact and WS 401 or 701C Wireless with charging	299
7.2.2.10	CXDI TS and WS 401 compact	301
7.2.2.11	CXDI TS and WS 401 compact 2 x free	303
7.2.2.12	CXDI TS 401C and WS 410 or 710C Wireless	305
7.2.2.13	CXDI TS 401C and WS 410 or 710C Wireless with charging	307
7.2.2.14	CXDI TS 410 or 710C Wireless and WS 401 compact	309
7.2.2.15	CXDI TS and WS 410 or 710C Wireless	311
7.2.2.16	CXDI TS and WS 410 or 710C Wireless, WS with charging	313
7.2.2.17	CXDI TS and WS 410 or 710C Wireless, WS with charging	315
7.2.2.18	CXDI TS 410 or 710C Wireless with charging and WS 401 compact	317
7.2.2.19	CXDI TS 410 or 710C Wireless with charging and WS 410 or 710C Wireless	319
7.2.3	Subsystem	321
7.2.3.1	System 0180_4	321
7.2.3.2	System CAN bus	323
7.2.3.3	System emergency stop, page 1	325
7.2.3.4	System emergency stop, page 2	327
7.2.3.5	System fail safe switches	329
7.2.3.6	Sync, delay OTC	331
7.2.3.7	Sync, delay, IR OTC	333
7.2.3.8	Sync, wall stand and system cabinet	335
7.2.4	Overhead tube crane	337
7.2.4.1	Overhead tube crane	337
7.2.5	System cabinet	339
7.2.5.1	System cabinet 4C	339
7.2.6	Closed table	341
7.2.6.1	0181_TS_4	341
7.2.7	Two column table (option)	343
7.2.7.1	Table 2 columns	343
7.2.8	Wall stand	345
7.2.8.1	Wall stand manual Z-movement	345
7.2.8.2	Wall stand motorized Z-movement	347
7.3	Unit block diagram (4C valid for Omnera 400T)	349
7.3.1	Image system	349

# Electrical drawings

---

7.3.1.1	Image system C .....	349
7.3.2	Closed table .....	351
7.3.2.1	Collimator control table .....	351
7.3.2.2	Detector holder 14x17 table .....	353
7.3.2.3	Detector holder 14x17 or 17x17 table.....	355
7.3.2.4	Detector holder 17x17 table .....	357
7.3.2.5	Detector holder 17x17 fixed table .....	359
7.3.2.6	Table power .....	361
7.3.2.7	Z potentiometer table.....	363
7.3.2.8	TS brakes .....	365
7.3.2.9	Z movement inc. Em stop.....	367
7.3.3	Two column table (option).....	369
7.3.3.1	CAN bus table.....	369
7.3.3.2	Collimator control table .....	371
7.3.3.3	Detector holder 14x17 table .....	373
7.3.3.4	Detector holder 14x17 or 17x17 table.....	375
7.3.3.5	Power table .....	377
7.3.3.6	Table top brakes.....	379
7.3.3.7	Z-movement table .....	381
7.3.4	Wall stand .....	383
7.3.4.1	CAN bus wall stand .....	383
7.3.4.2	Collimator control wall stand.....	385
7.3.4.3	Detector holder 14x17, wall stand.....	387
7.3.4.4	Detector holder 17x17 fix wall stand.....	389
7.3.4.5	Detector holder 14x17 or 17x17 wall stand .....	391
7.3.4.6	Power manual wall stand .....	393
7.3.4.7	Power motorized wall stand.....	395
7.3.4.8	Detector tilt and WS indication.....	397
7.3.4.9	Z movement motorized .....	399
7.3.4.10	Z movement manual .....	401
7.3.5	OTC.....	403
7.3.5.1	CAN bus OTC .....	403
7.3.5.2	Collimator control OTC page 1 .....	405
7.3.5.3	Ralco 302 F/A OTC page 2 .....	407
7.3.5.4	Siemens AL02 OTC page 3.....	409
7.3.5.5	DAP meter OTC.....	411
7.3.5.6	Display unit OTC .....	413
7.3.5.7	Power OTC.....	415
7.3.5.8	X-ray tube OTC.....	417
7.3.6	System cabinet .....	419
7.3.6.1	Generator to system SC 4C .....	419



## 7.1 Notes regarding the electrical drawings

- Options are not available on all markets.
- Where electrical drawings describes several versions, 4C is applicable for Omnera 400T.
- Electrical drawings for CXDI410C and 710C are also valid for CXDI402C and 702C.

# Electrical drawings

---

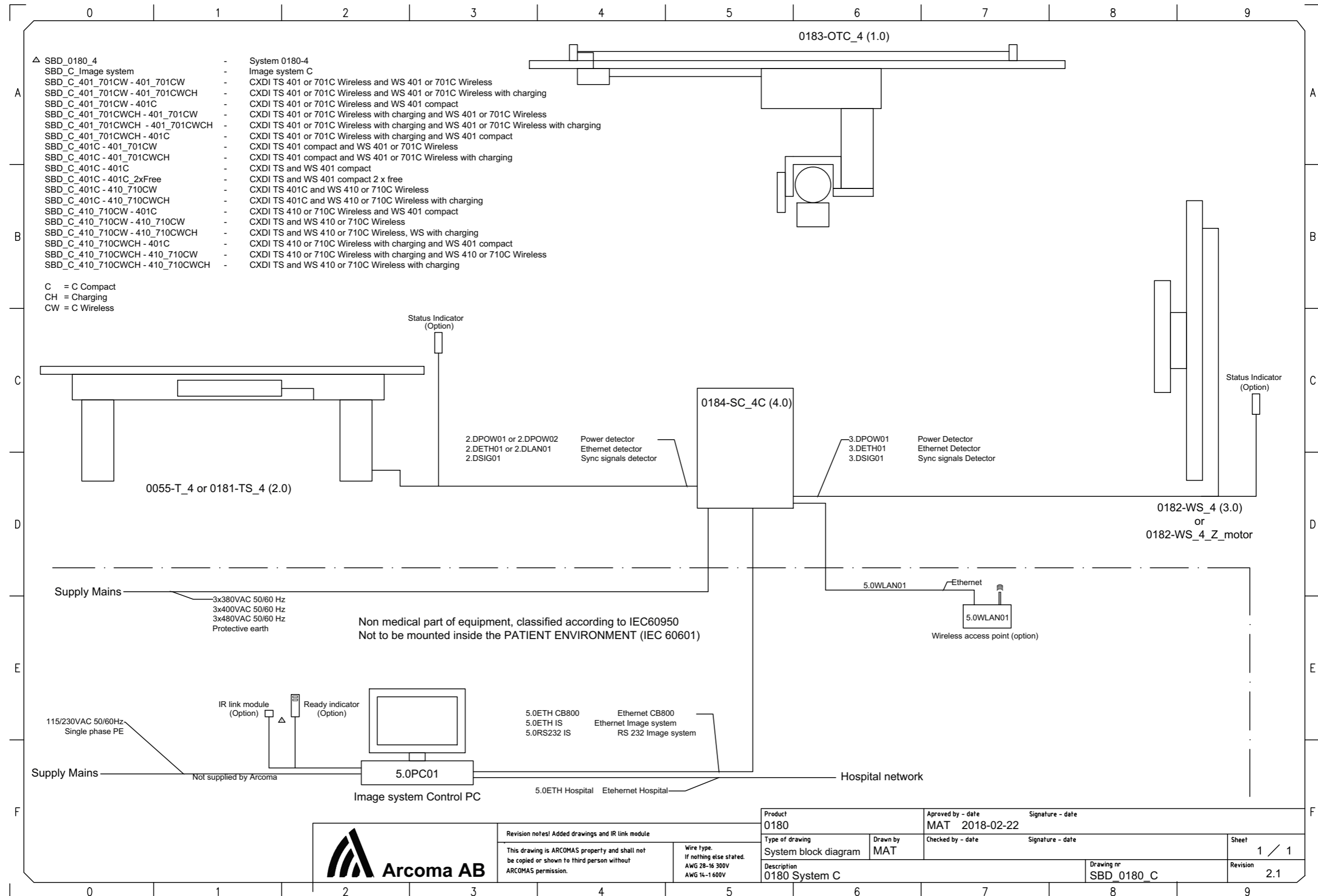



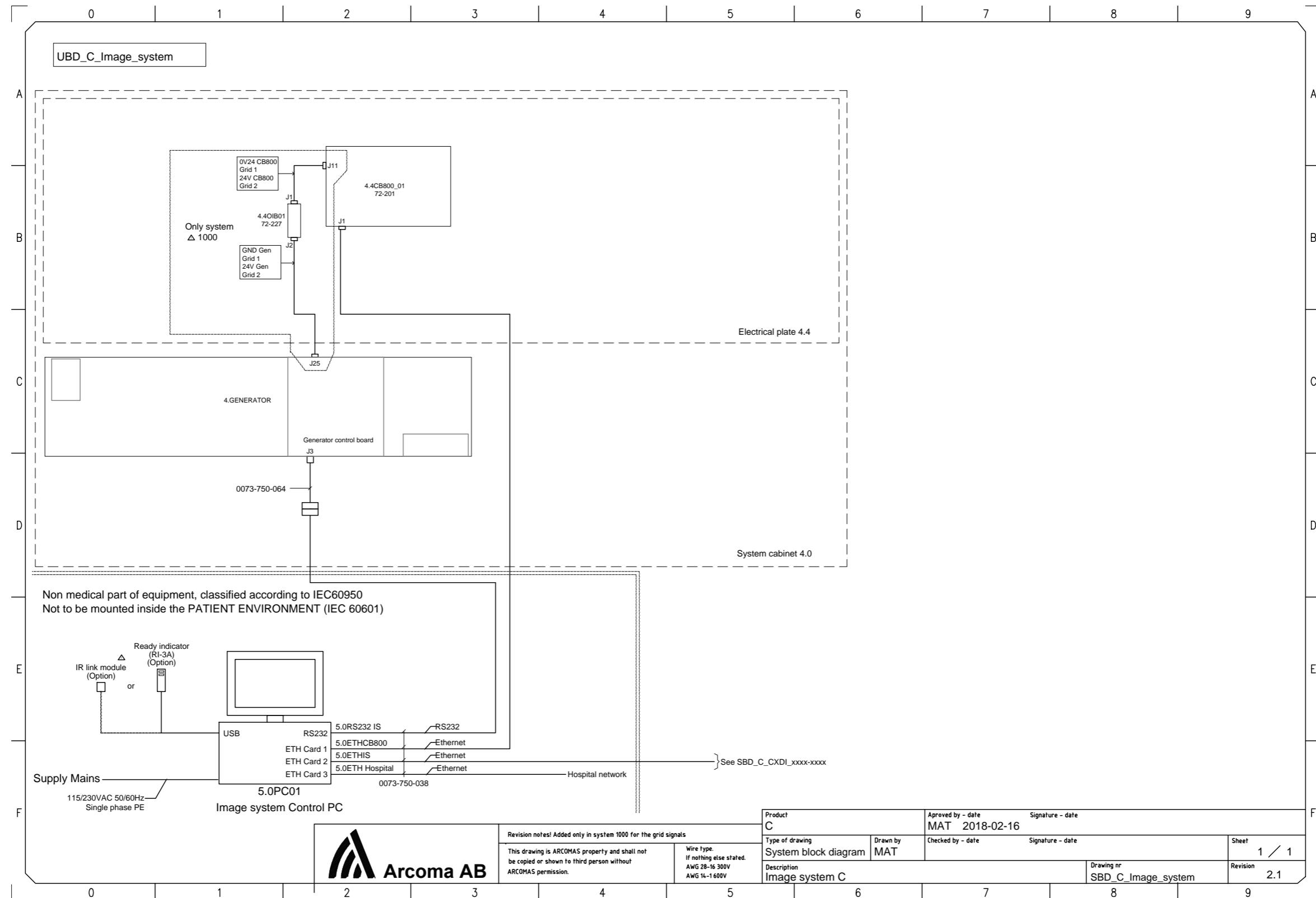



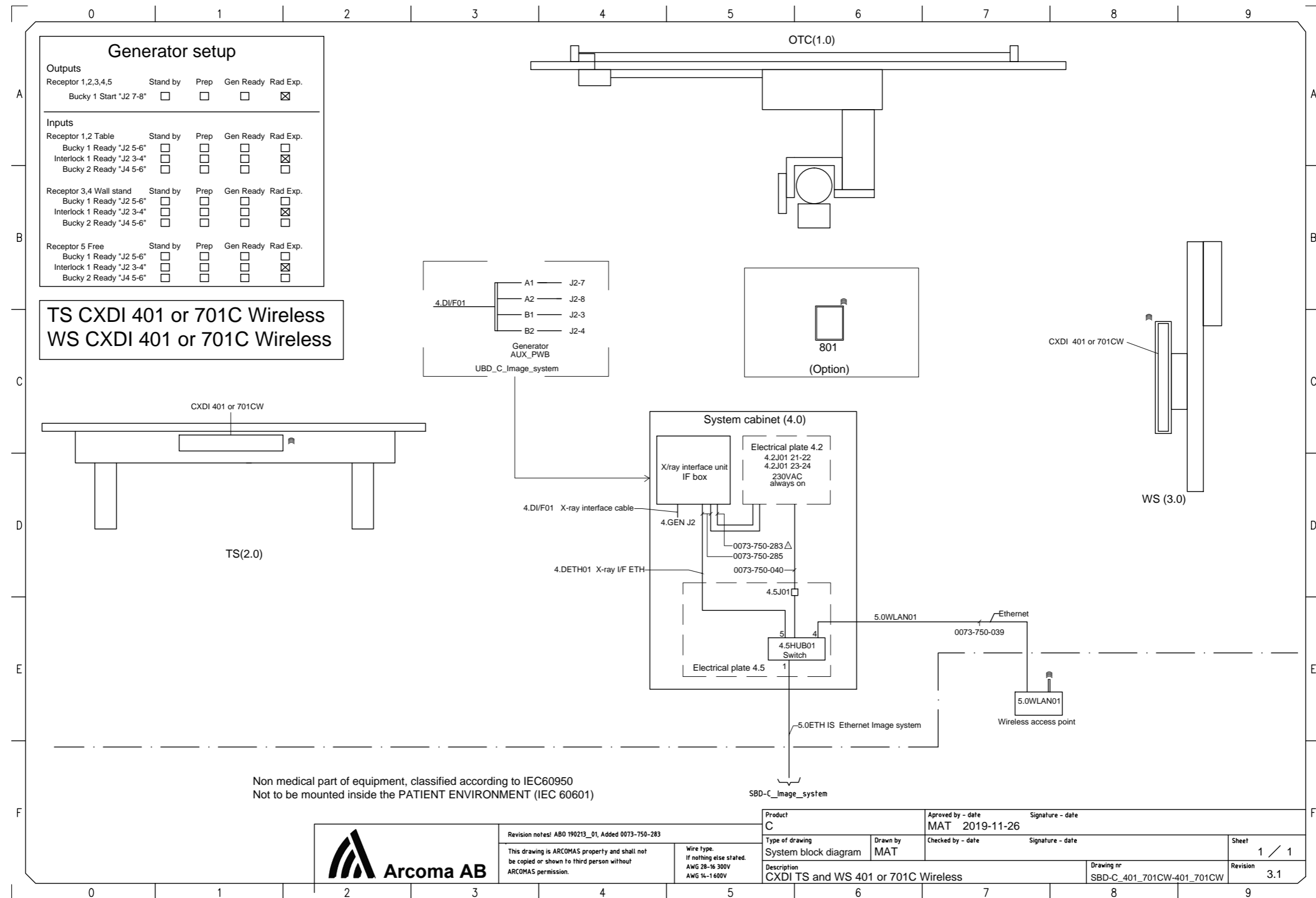

Revision notes! ABO 190213\_01, Added 0073-750-283

This drawing is ARCOMAS property and shall not be copied or shown to third person without ARCOMAS permission.

Wire type:  
If nothing else stated:  
AWG 28-16 300V  
AWG 14-1 600V

Product C	Approved by - date MAT 2019-11-26	Signature - date
Type of drawing System block diagram	Drawn by MAT	Checked by - date
Description CXDI TS and WS 401 or 701C Wireless		Signature - date
Drawing nr SBD-C_401_701CW-401_701CW		Sheet 1 / 1
Revision 3.1		





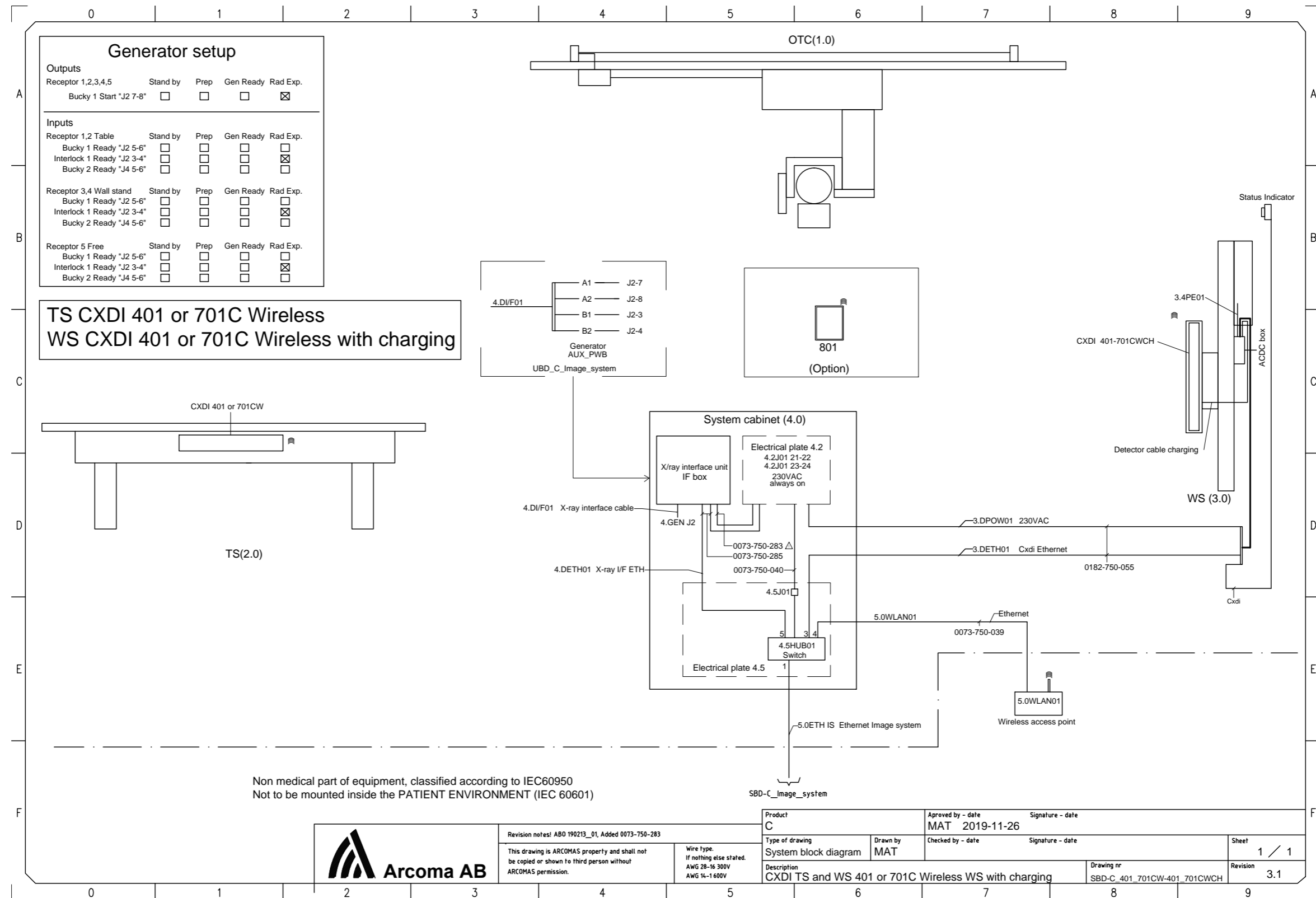

Revision notes! ABO 190213\_01, Added 0073-750-283  
 This drawing is ARCOMAS property and shall not be copied or shown to third person without ARCOMAS permission.  
 Wire type:  
 If nothing else stated:  
 AWG 28-16 300V  
 AWG 14-1 600V

Product <b>C</b>	Approved by - date <b>MAT 2019-11-26</b>	Signature - date
Type of drawing System block diagram	Drawn by <b>MAT</b>	Checked by - date
Description <b>CXDI TS and WS 401 or 701C Wireless WS with charging</b>		Drawing nr SBD-C_401_701CW-401_701CWCH
Sheet <b>1 / 1</b>		Revision <b>3.1</b>



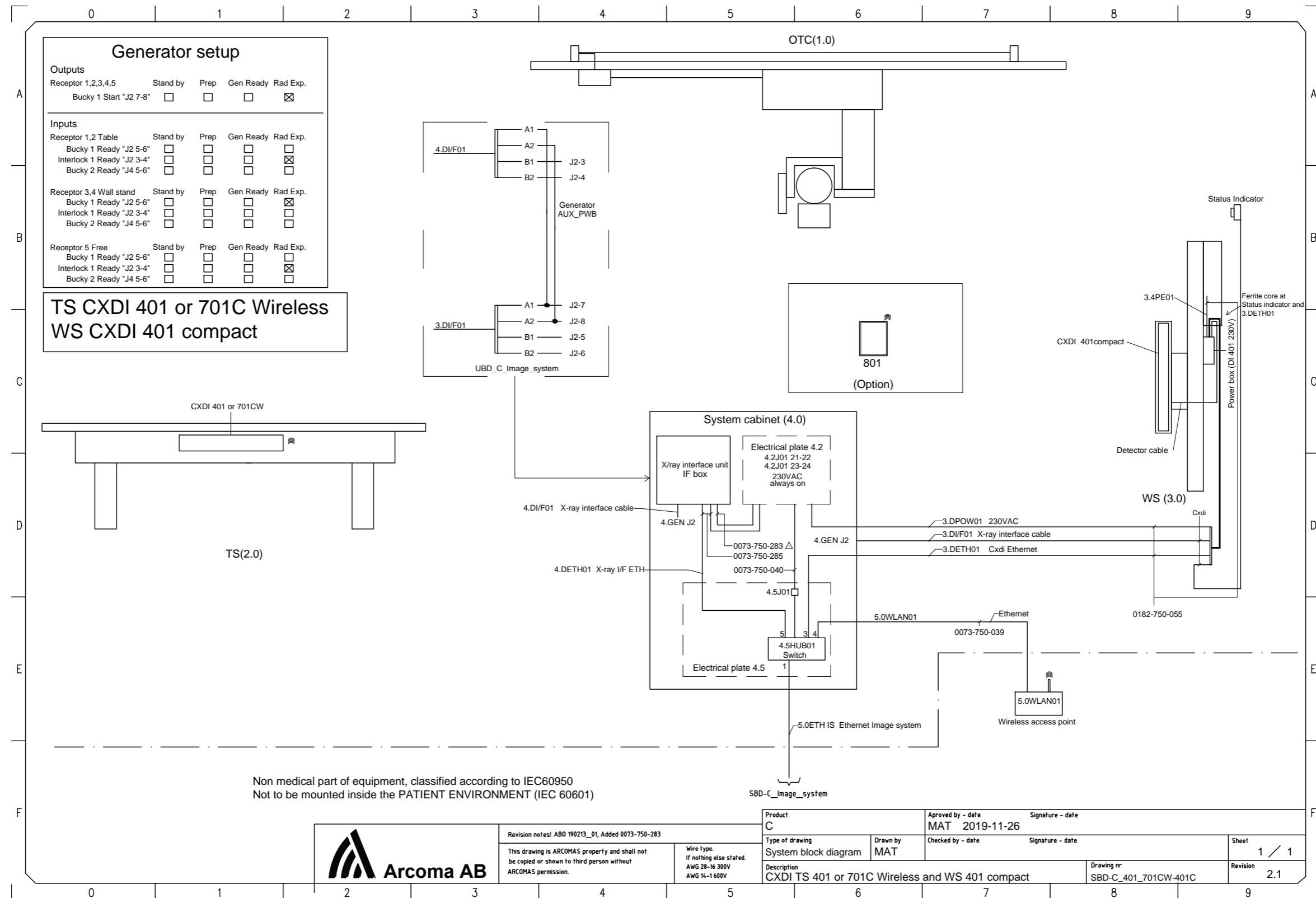

Non medical part of equipment, classified according to IEC60950  
Not to be mounted inside the PATIENT ENVIRONMENT (IEC 60601)



Revision notes! ABO 190213\_01, Added 0073-750-283

This drawing is ARCOMAS property and shall not be copied or shown to third person without ARCOMAS permission.

Wire type:  
If nothing else stated:  
AWG 28-16 300V  
AWG 14-1 600V

Product C	Approved by - date MAT 2019-11-26	Signature - date
Type of drawing System block diagram	Checked by - date	Signature - date
Description CXDI TS 401 or 701C Wireless and WS 401 compact		Drawing nr SBD-C_401_701CW-401C
		Sheet 1 / 1
		Revision 2.1



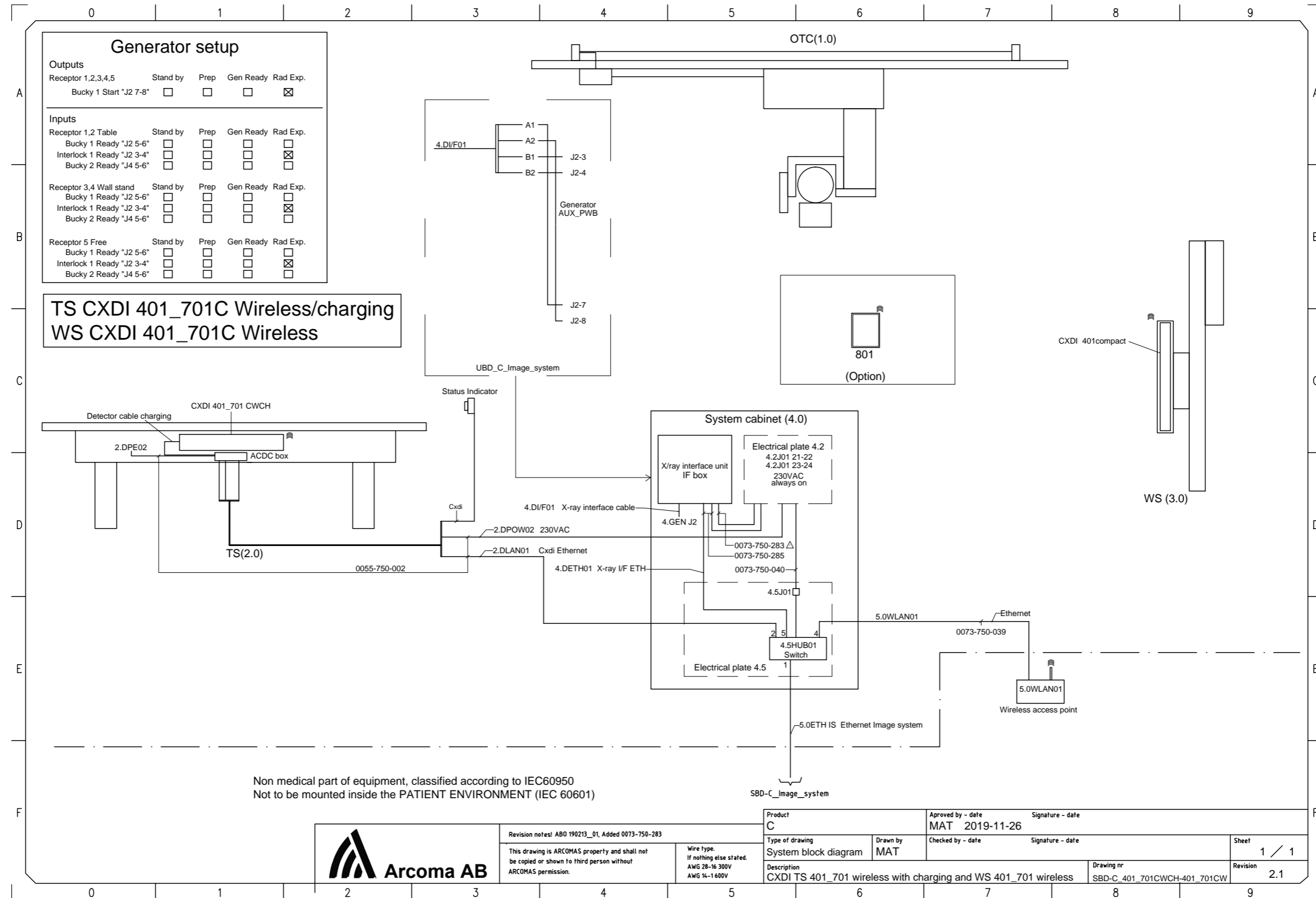



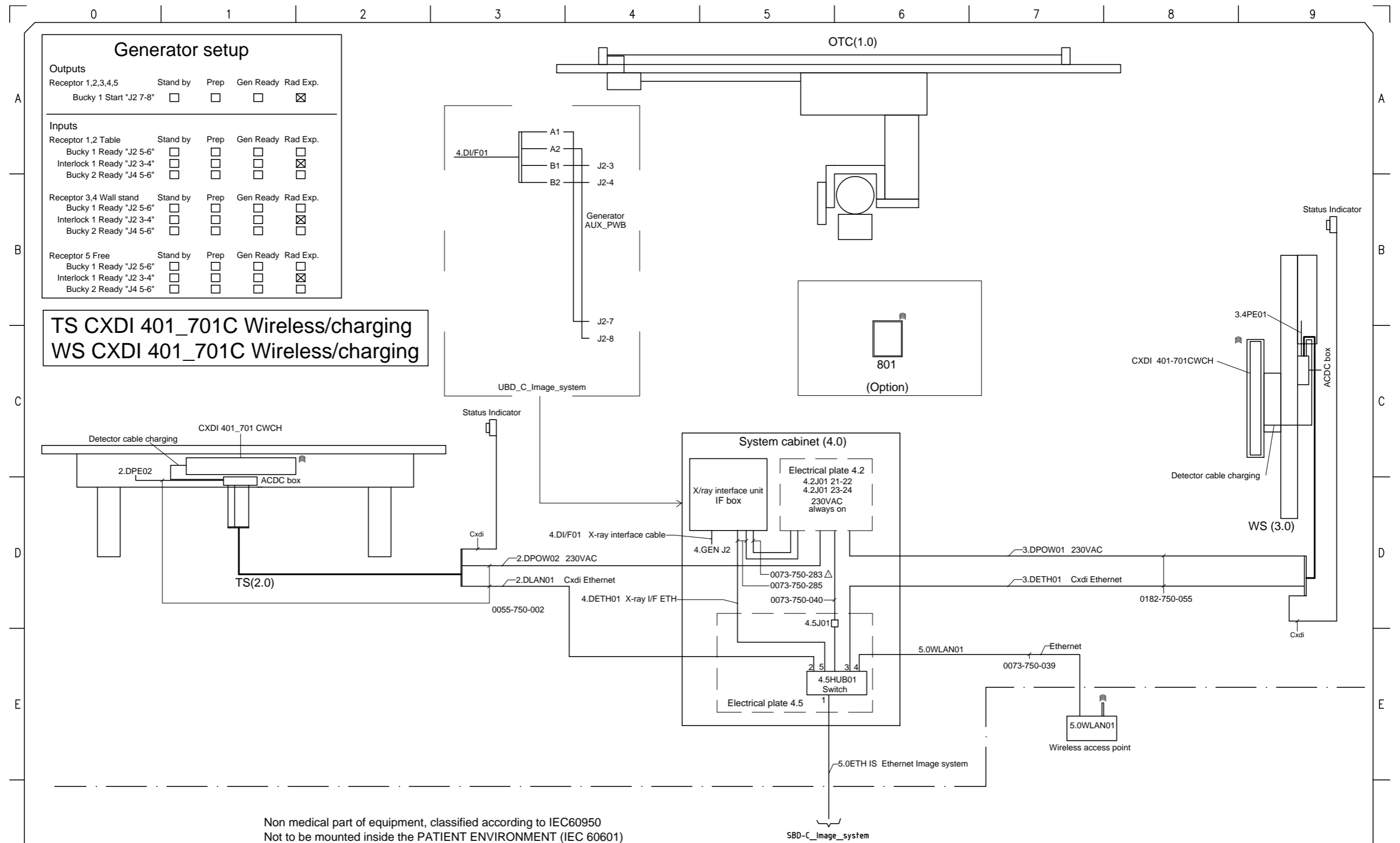

Non medical part of equipment, classified according to IEC60950  
Not to be mounted inside the PATIENT ENVIRONMENT (IEC 60601)



Revision notes! ABO 190213\_01, Added 0073-750-283  
This drawing is ARCOMAS property and shall not be copied or shown to third person without ARCOMAS permission.  
Wire type. If nothing else stated. AWG 28-16 300V AWG 14-1600V

Product <b>C</b>	Approved by - date <b>MAT 2019-11-26</b>	Signature - date
Type of drawing System block diagram	Drawn by <b>MAT</b>	Checked by - date Signature - date
Description CXDI TS and WS 401_701 wireless with charging	Drawing nr SBD-C_401_701CWCH-401_701CWCH	Sheet 1 / 1
		Revision 2.1





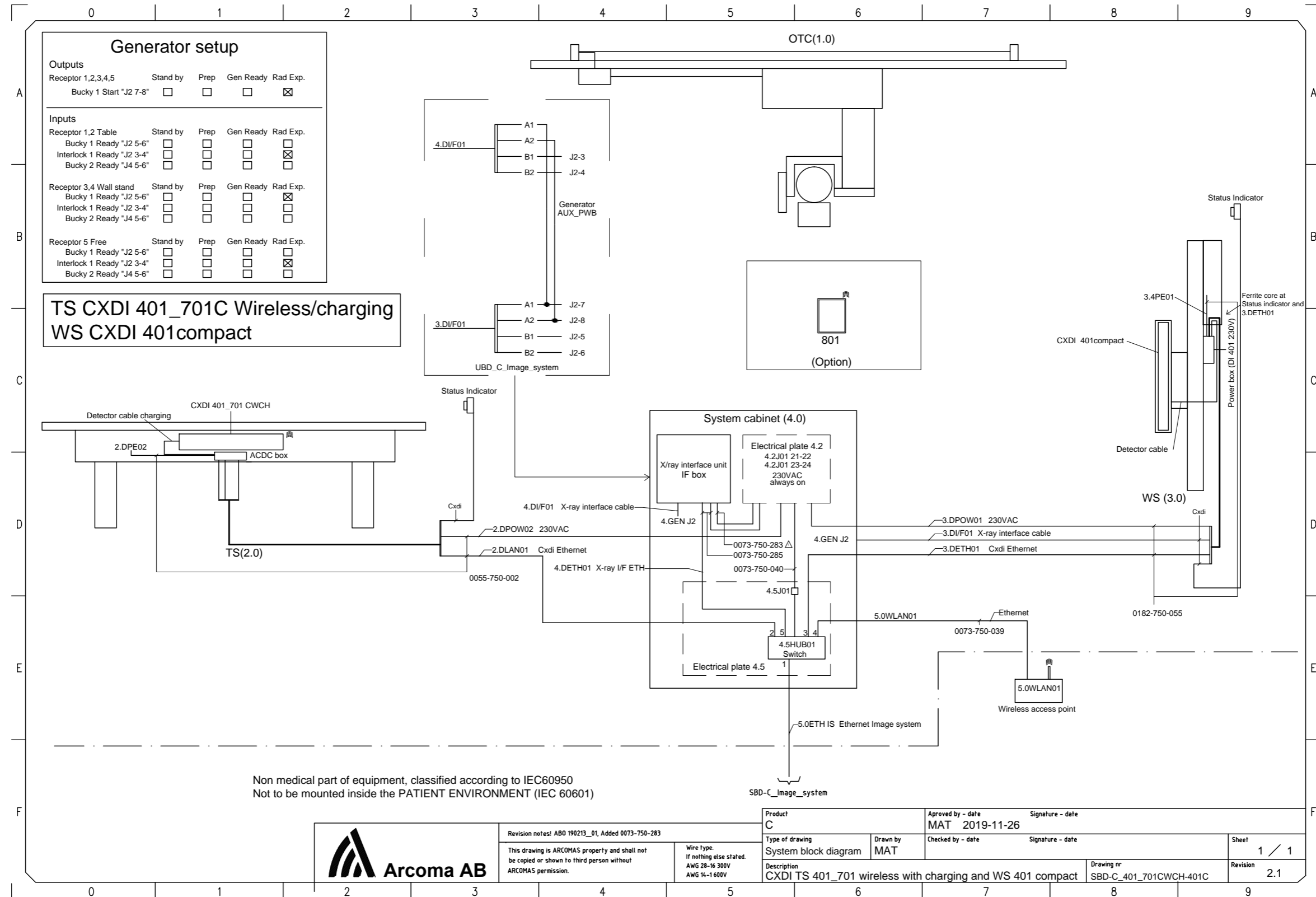

Revision notes! ABO 190213\_01, Added 0073-750-283

This drawing is ARCOMAS property and shall not be copied or shown to third person without ARCOMAS permission.

Wire type:  
If nothing else stated:  
AWG 28-16 300V  
AWG 14-1 600V

Product C	Approved by - date MAT 2019-11-26	Signature - date
Type of drawing System block diagram	Drawn by MAT	Checked by - date
Description CXDI TS 401_701 wireless with charging and WS 401 compact		Signature - date
Drawing nr SBD-C_401_701CWCH-401C		Sheet 1 / 1
Revision 2.1		



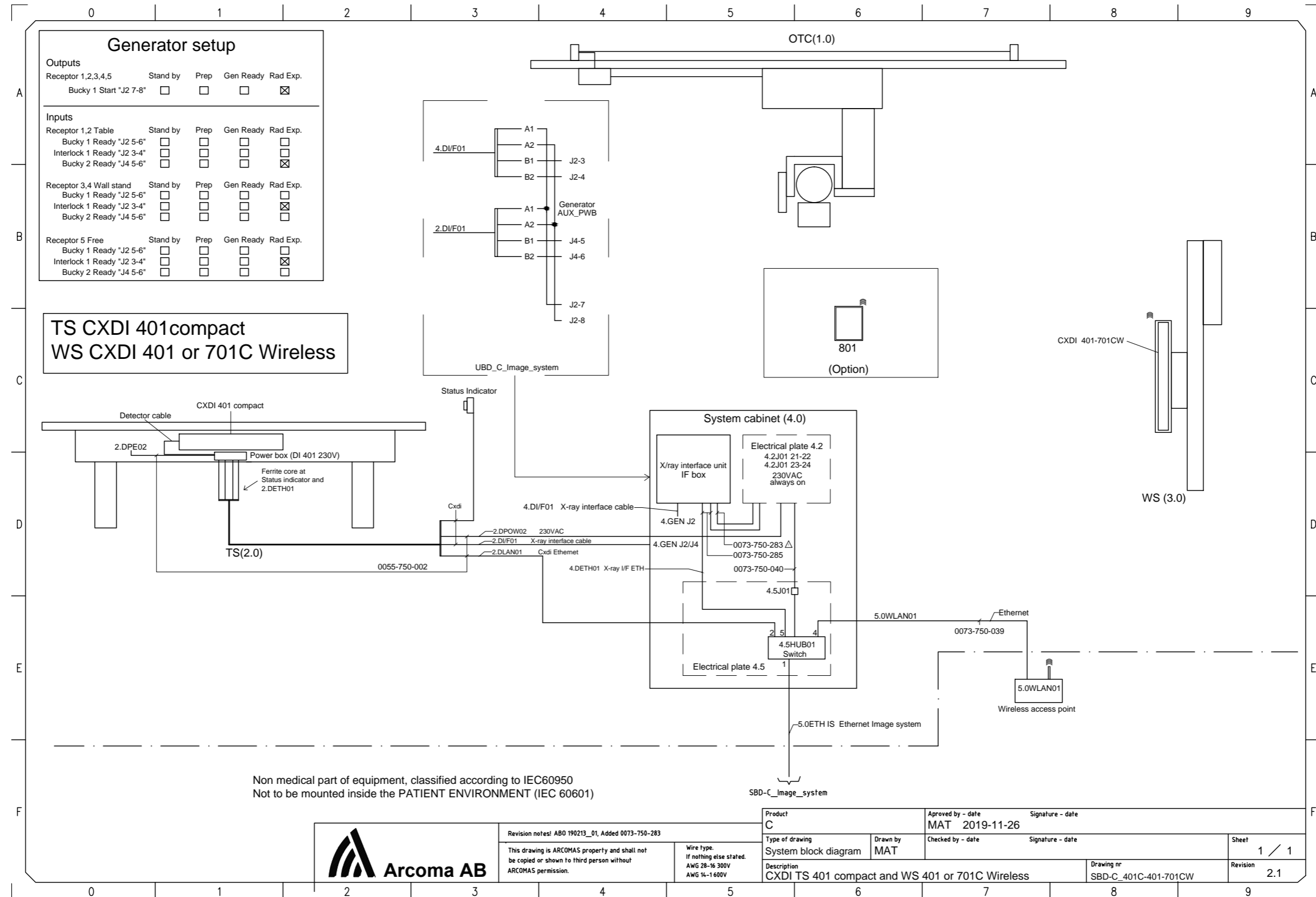

Revision notes! ABO 190213\_01, Added 0073-750-283

This drawing is ARCOMAS property and shall not be copied or shown to third person without ARCOMAS permission.

Wire type:  
 If nothing else stated:  
 AWG 28-16 300V  
 AWG 14-1 600V

Product C	Approved by - date MAT 2019-11-26	Signature - date
Type of drawing System block diagram	Checked by - date	Signature - date
Description CXDI TS 401 compact and WS 401 or 701C Wireless		Drawing nr SBD-C_401C-401-701CW
		Sheet 1 / 1
		Revision 2.1



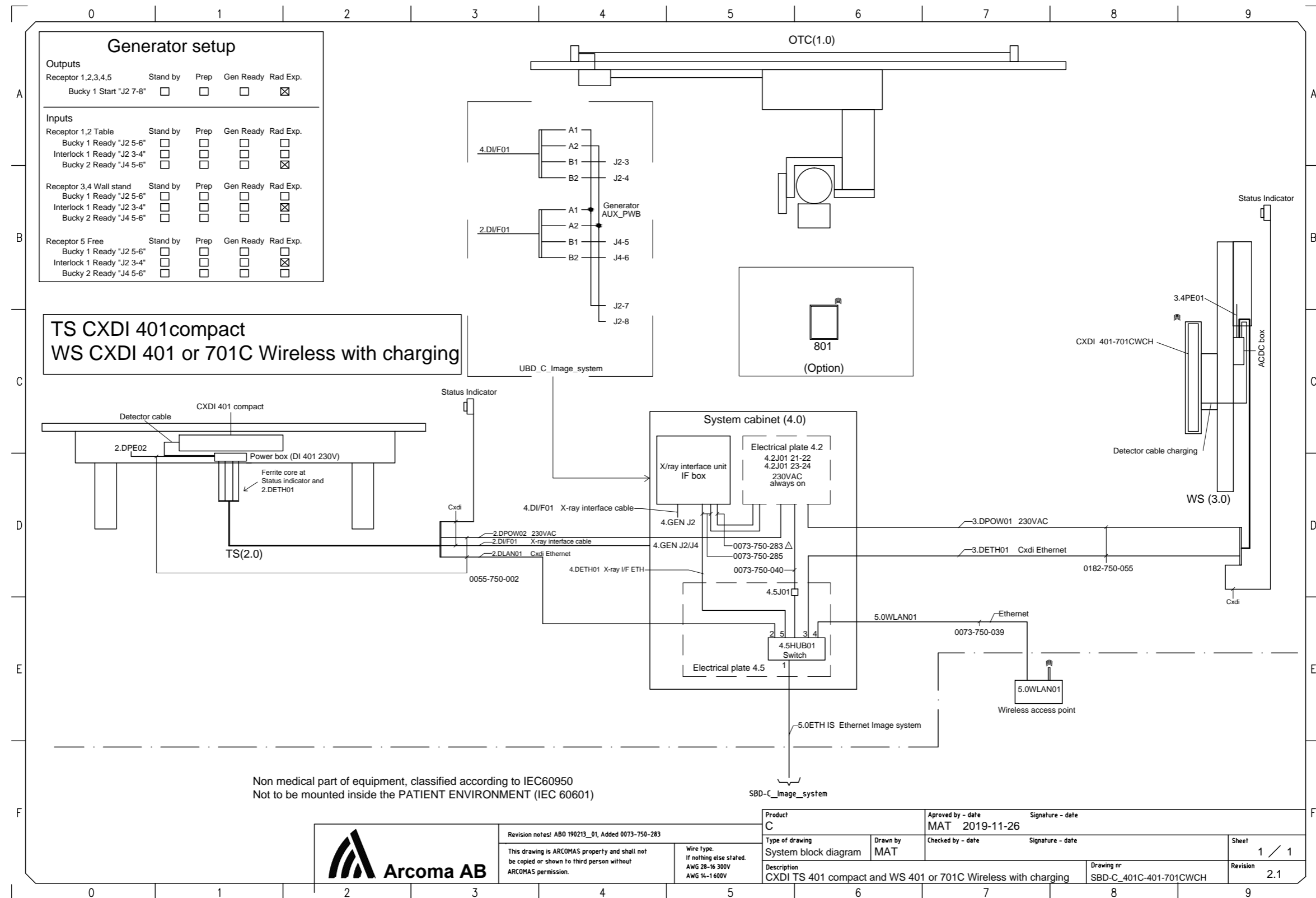

Revision notes! ABO 190213\_01, Added 0073-750-283

This drawing is ARCOMAS property and shall not be copied or shown to third person without ARCOMAS permission.

Wire type:  
If nothing else stated:  
AWG 28-16 300V  
AWG 14-1 600V

Product C	Approved by - date MAT 2019-11-26	Signature - date
Type of drawing System block diagram	Checked by - date	Signature - date
Description CXDI TS 401 compact and WS 401 or 701C Wireless with charging		Drawing nr SBD-C_401C-401-701CWCH
		Sheet 1 / 1
		Revision 2.1



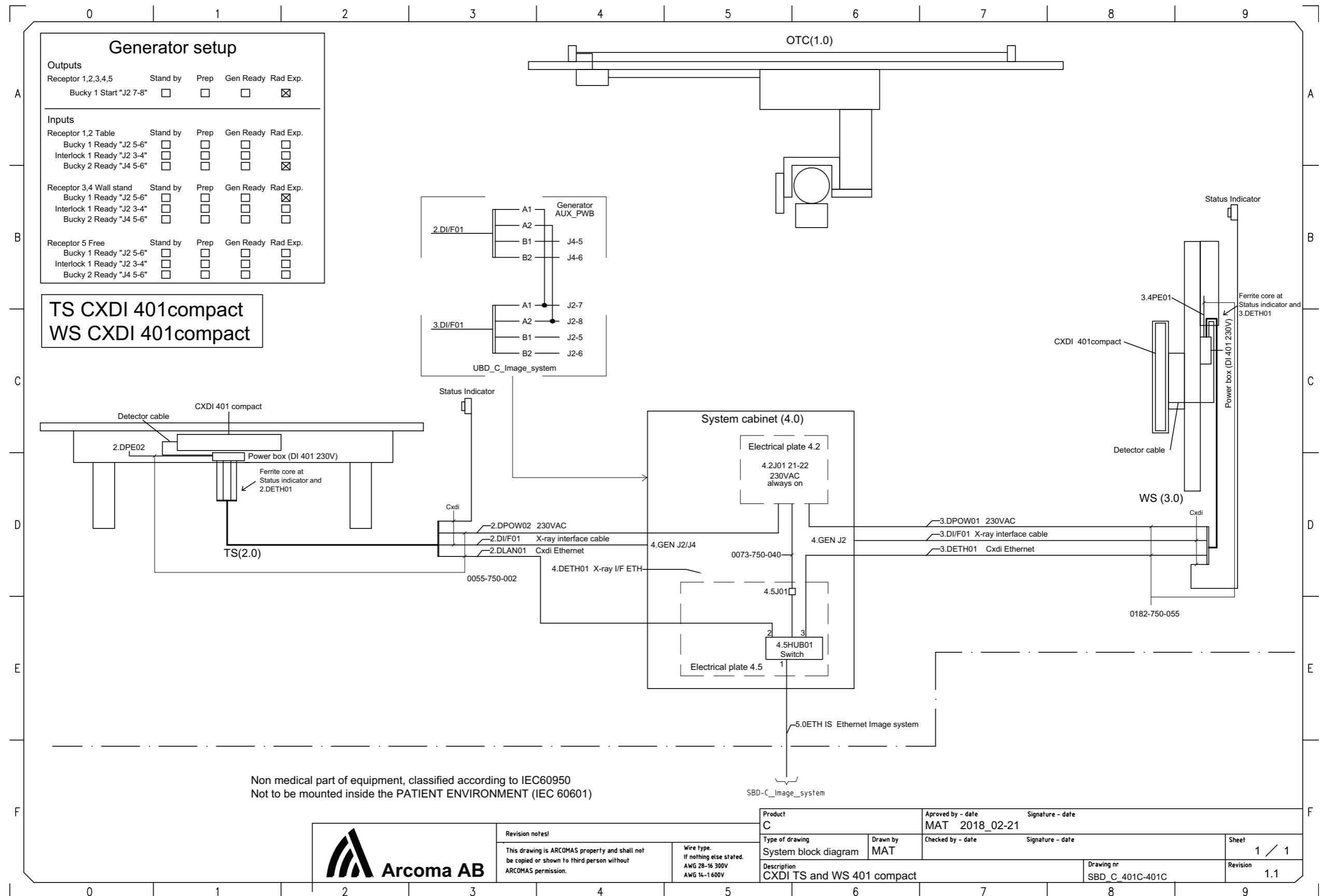





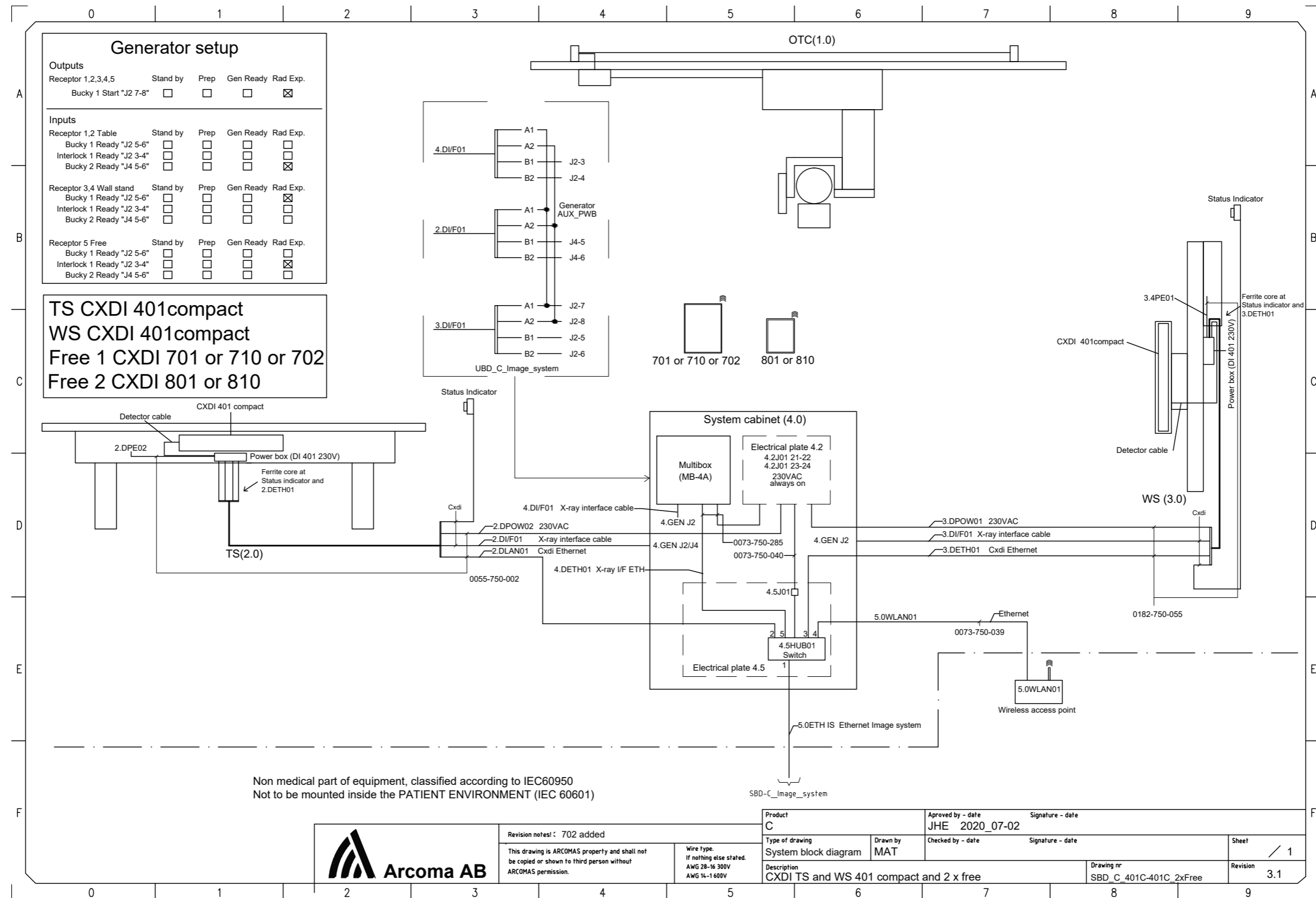

Revision notes: 702 added

This drawing is ARCOMAS property and shall not be copied or shown to third person without ARCOMAS permission.

Wire type:  
 If nothing else stated:  
 AWG 28-16 300V  
 AWG 14-1 600V

Product C	Approved by - date JHE 2020_07-02	Signature - date
Type of drawing System block diagram	Drawn by MAT	Checked by - date
Description CXDI TS and WS 401 compact and 2 x free		Sheet 1
Drawing nr SBD_C_401C-401C_2xFree		Revision 3.1



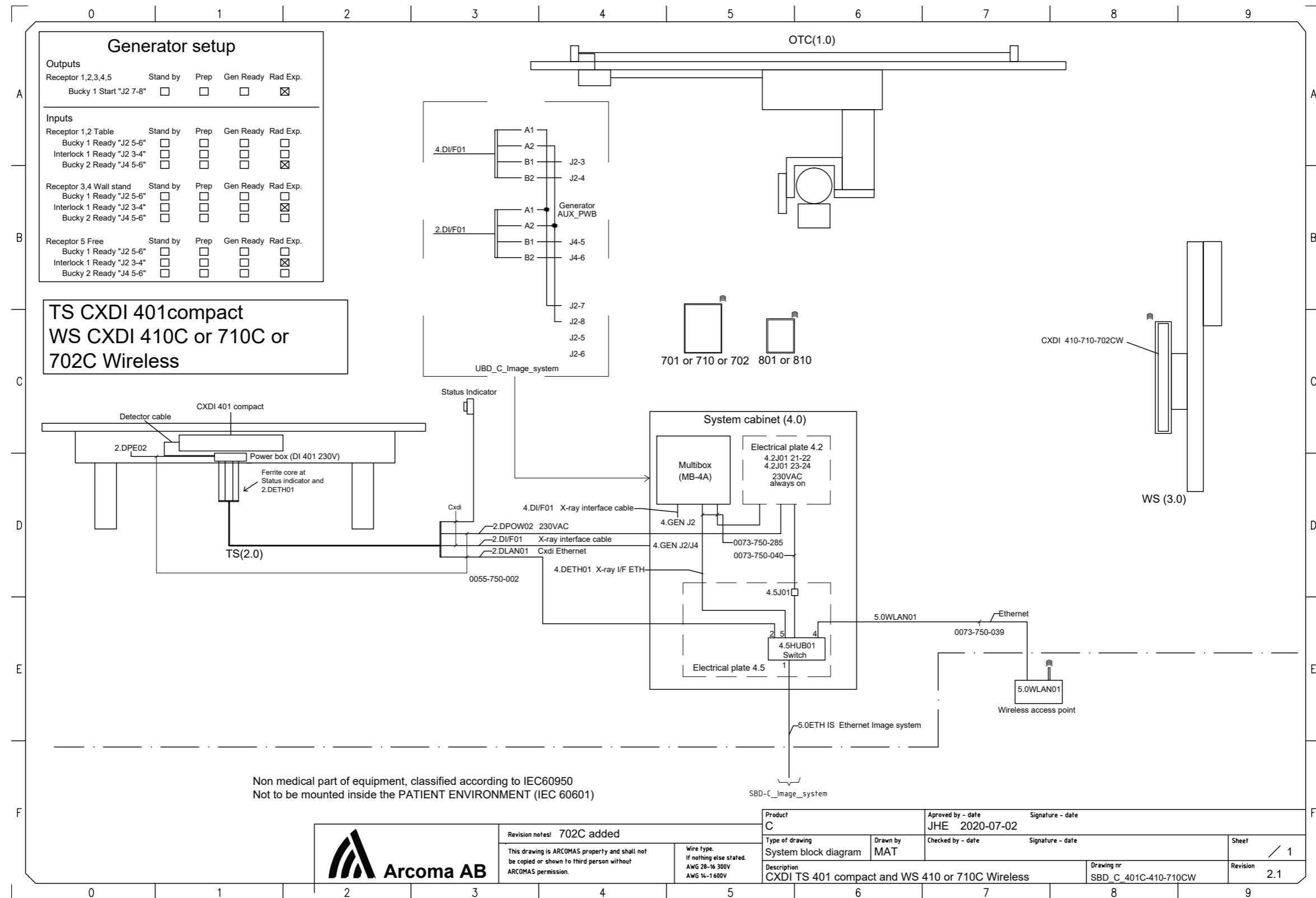

Revision notes! 702C added

This drawing is ARCOMAS property and shall not be copied or shown to third person without ARCOMAS permission.

Wire type. If nothing else stated. AWG 28-16 300V AWG 14-1 600V

Product C	Approved by - date JHE 2020-07-02	Signature - date
Type of drawing System block diagram	Drawn by MAT	Checked by - date
Description CXDI TS 401 compact and WS 410 or 710C Wireless	Drawing nr SBD_C_401C-410-710CW	Revision 2.1
Sheet / 1		



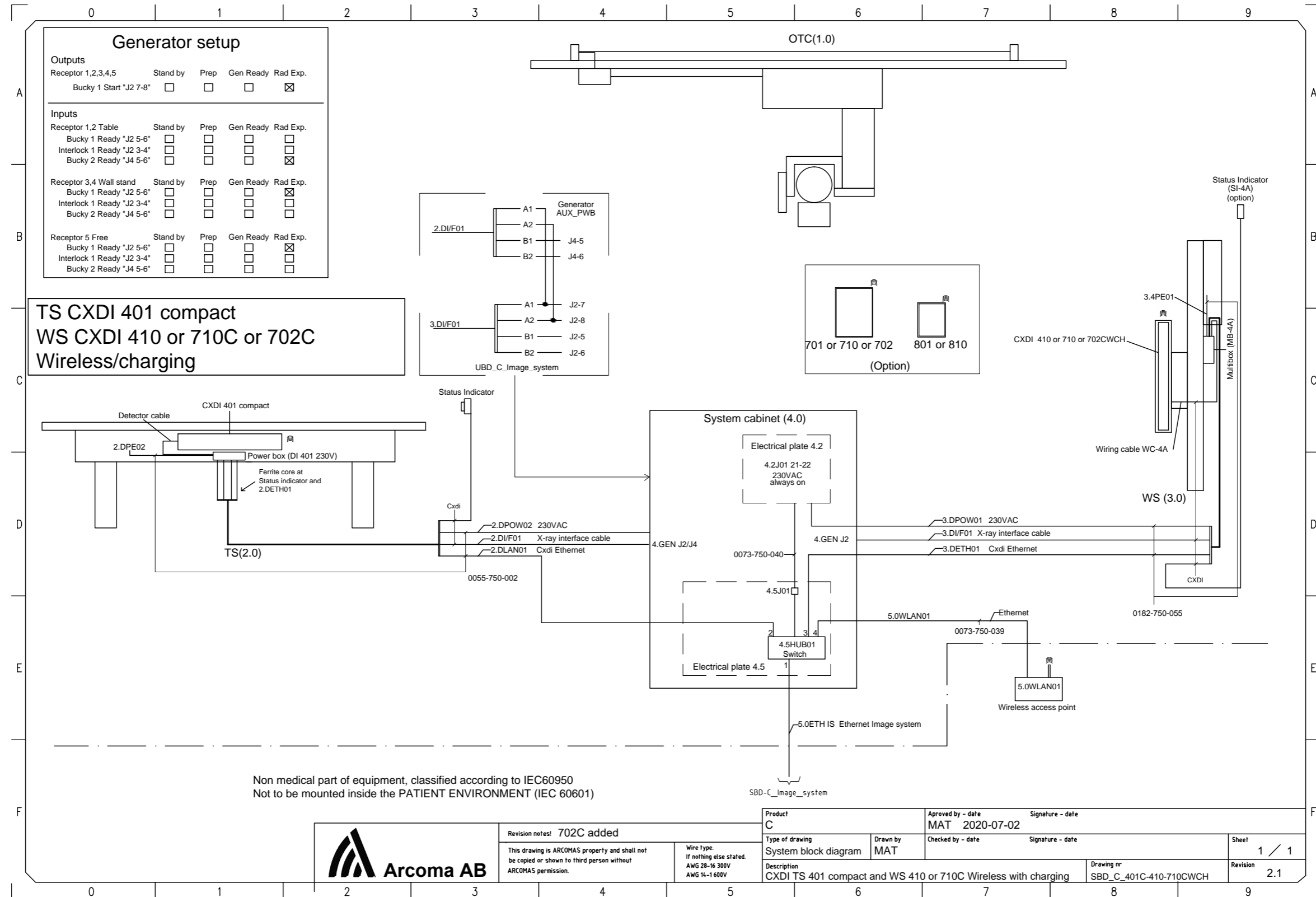

Revision notes! 702C added

This drawing is ARCOMAS property and shall not be copied or shown to third person without ARCOMAS permission.

Wire type:  
 If nothing else stated:  
 AWG 28-16 300V  
 AWG 14-1 600V

Product C	Approved by - date MAT 2020-07-02	Signature - date
Type of drawing System block diagram	Checked by - date	Signature - date
Description CXDI TS 401 compact and WS 410 or 710C Wireless with charging		Drawing nr SBD_C_401C-410-710CWCH
		Sheet 1 / 1
		Revision 2.1



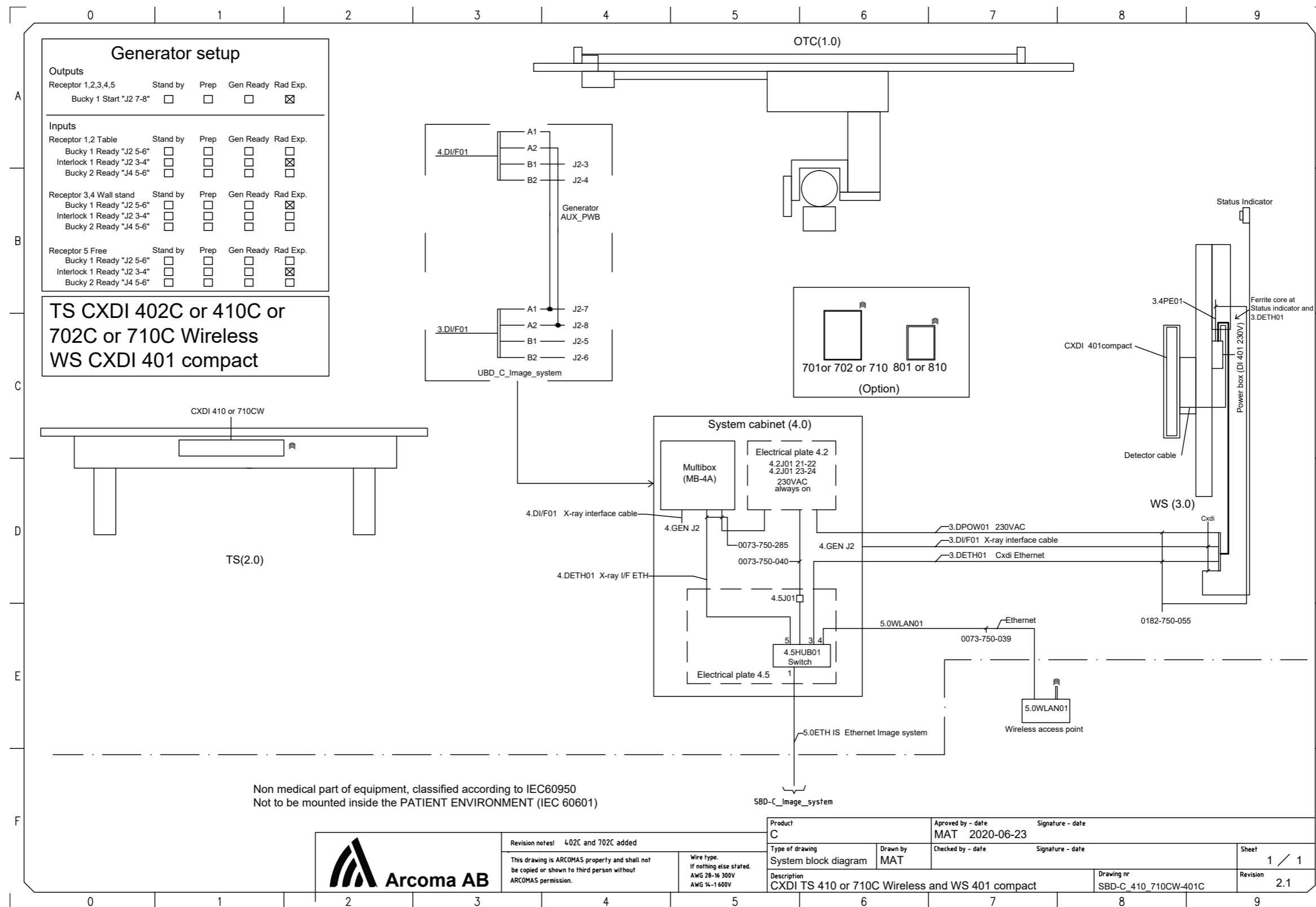

Non medical part of equipment, classified according to IEC60950  
Not to be mounted inside the PATIENT ENVIRONMENT (IEC 60601)



Revision notes! 402C and 702C added  
This drawing is ARCOMAS property and shall not be copied or shown to third person without ARCOMAS permission.  
Wire type: If nothing else stated. AWG 28-16 300V AWG 14-1 600V

Product C	Approved by - date MAT 2020-06-23	Signature - date
Type of drawing System block diagram	Checked by - date	Signature - date
Description CXDI TS 410 or 710C Wireless and WS 401 compact		Sheet 1 / 1
Drawing nr SBD-C 410 710CW-401C		Revision 2.1





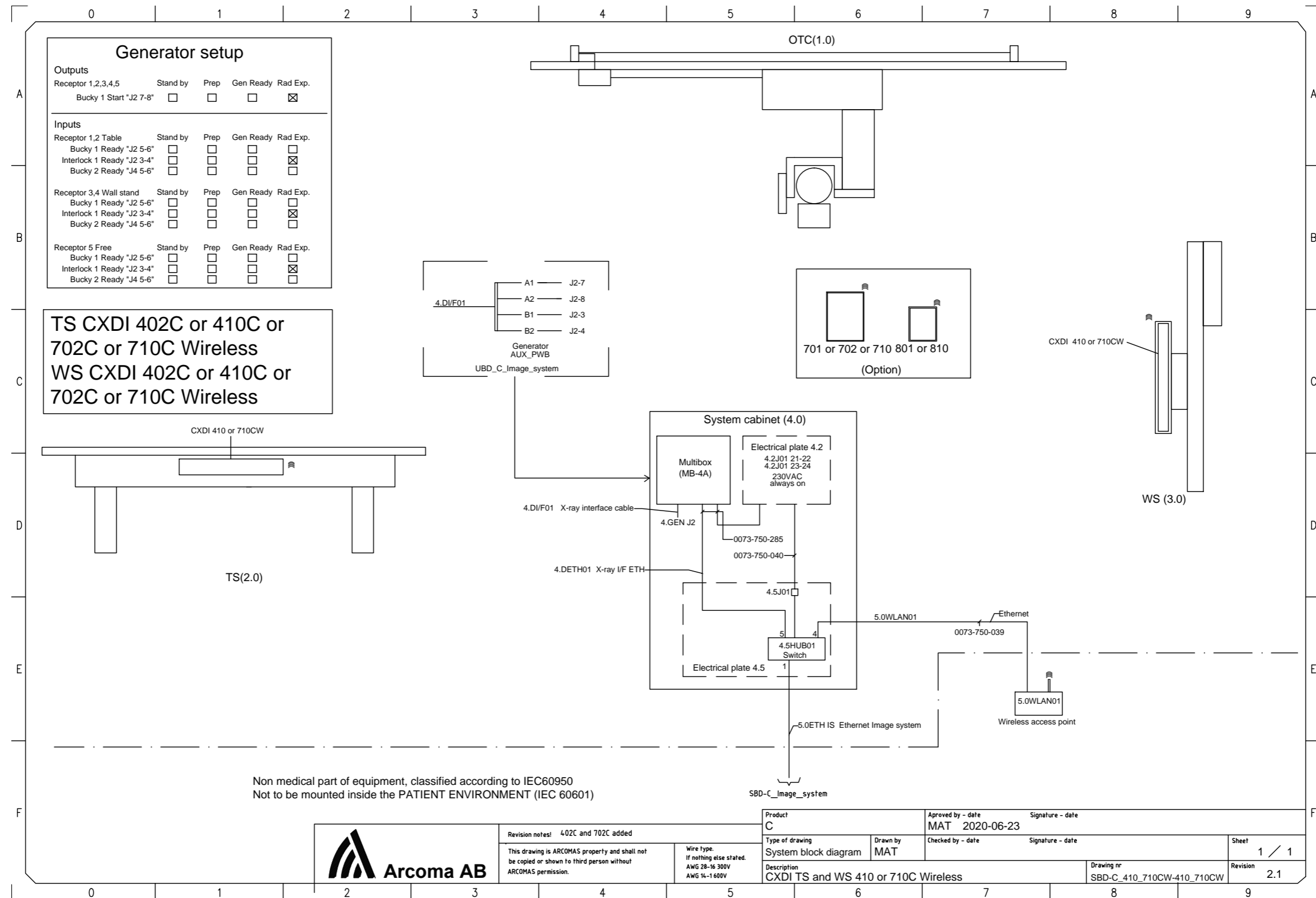

Revision notes! 402C and 702C added

This drawing is ARCOMAS property and shall not be copied or shown to third person without ARCOMAS permission.

Wire type. If nothing else stated. AWG 28-16 300V AWG 14-1 600V

Product	C	Approved by - date	MAT 2020-06-23	Signature - date	
Type of drawing	System block diagram	Drawn by	MAT	Checked by - date	Signature - date
Description	CXDI TS and WS 410 or 710C Wireless		Drawing nr	SBD-C_410_710CW-410_710CW	Revision
					2.1
					Sheet 1 / 1



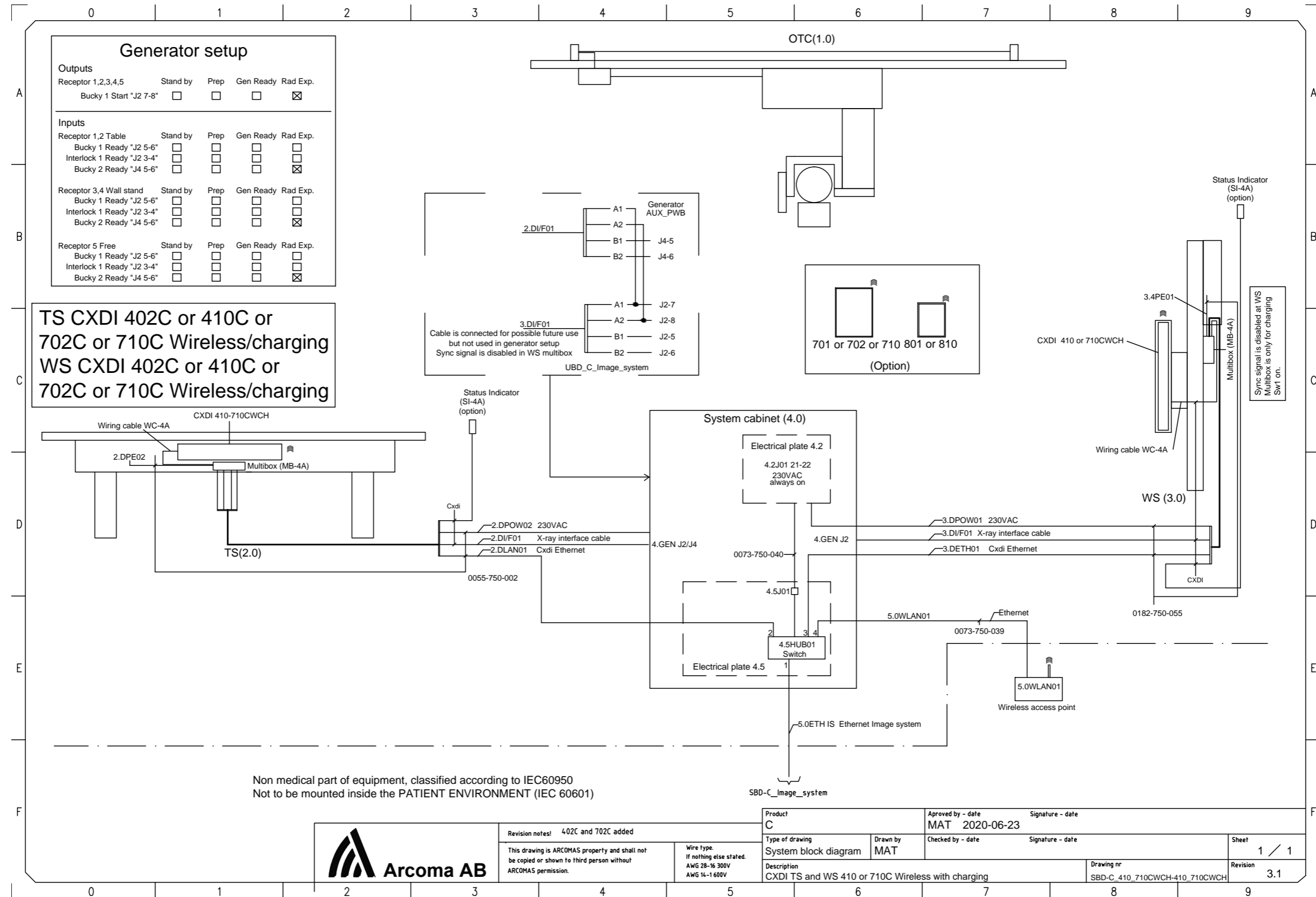



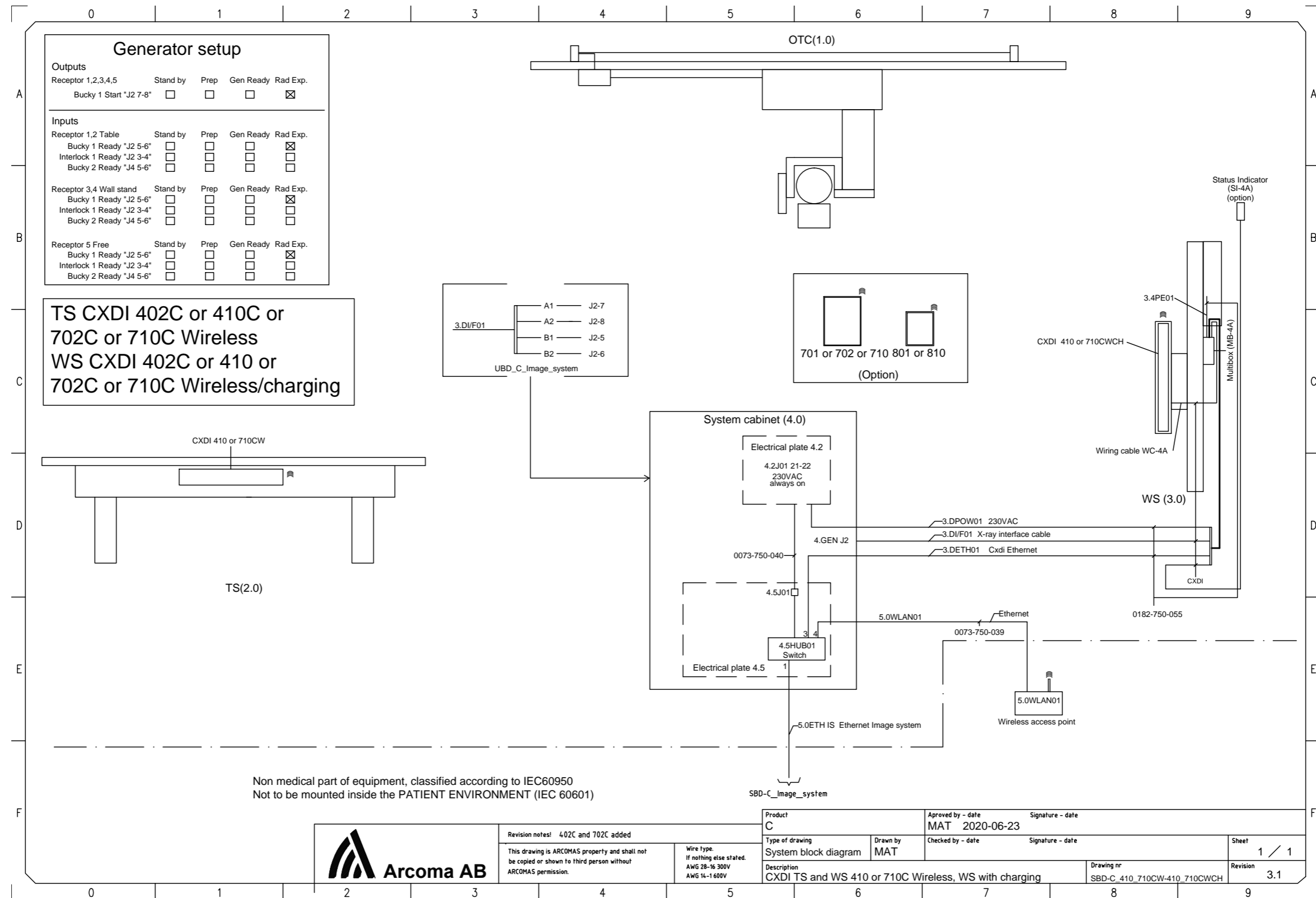

Revision notes! 402C and 702C added

This drawing is ARCOMAS property and shall not be copied or shown to third person without ARCOMAS permission.

Wire type:  
 If nothing else stated:  
 AWG 28-16 300V  
 AWG 14-1 600V

Product C	Approved by - date MAT 2020-06-23	Signature - date
Type of drawing System block diagram	Drawn by MAT	Checked by - date
Description CXDI TS and WS 410 or 710C Wireless, WS with charging		Signature - date
Drawing nr SBD-C 410 710CW-410 710CWCH		Sheet 1 / 1
Revision 3.1		



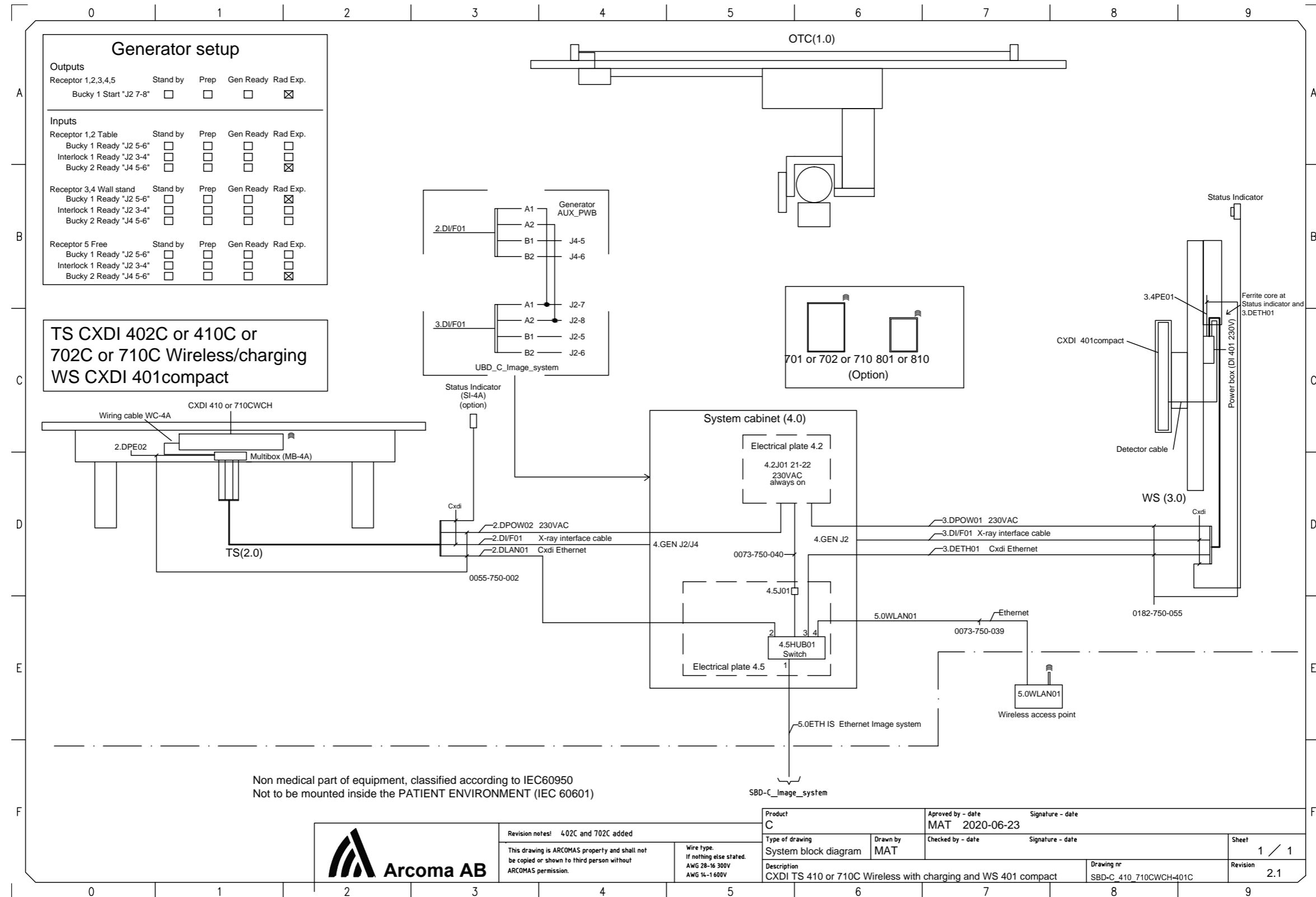

Revision notes! 402C and 702C added

This drawing is ARCOMAS property and shall not be copied or shown to third person without ARCOMAS permission.

Wire type:  
If nothing else stated:  
AWG 28-16 300V  
AWG 14-1 600V

Product C	Approved by - date MAT 2020-06-23	Signature - date
Type of drawing System block diagram	Checked by - date	Signature - date
Description CXDI TS 410 or 710C Wireless with charging and WS 401 compact		Sheet 1 / 1
Drawing nr SBD-C 410 710CWCH-401C		Revision 2.1





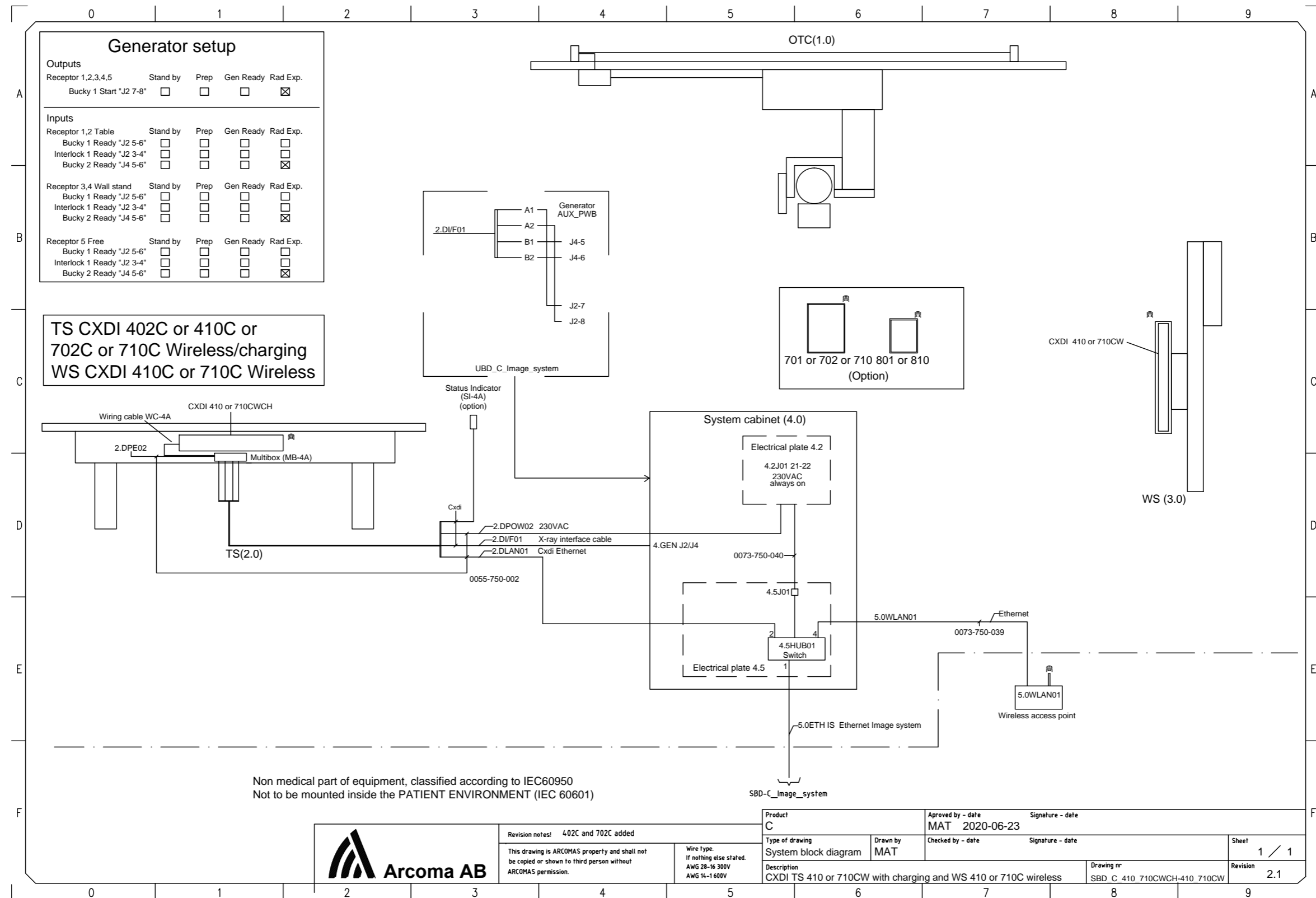

Revision notes! 402C and 702C added  
This drawing is ARCOMAS property and shall not be copied or shown to third person without ARCOMAS permission.  
Wire type. If nothing else stated. AWG 28-16 300V AWG 14-1 600V

Product C	Approved by - date MAT 2020-06-23	Signature - date
Type of drawing System block diagram	Checked by - date	Signature - date
Description CXDI TS 410 or 710CW with charging and WS 410 or 710C wireless		Drawing nr SBD_C_410_710CWCH-410_710CW
		Sheet 1 / 1
		Revision 2.1



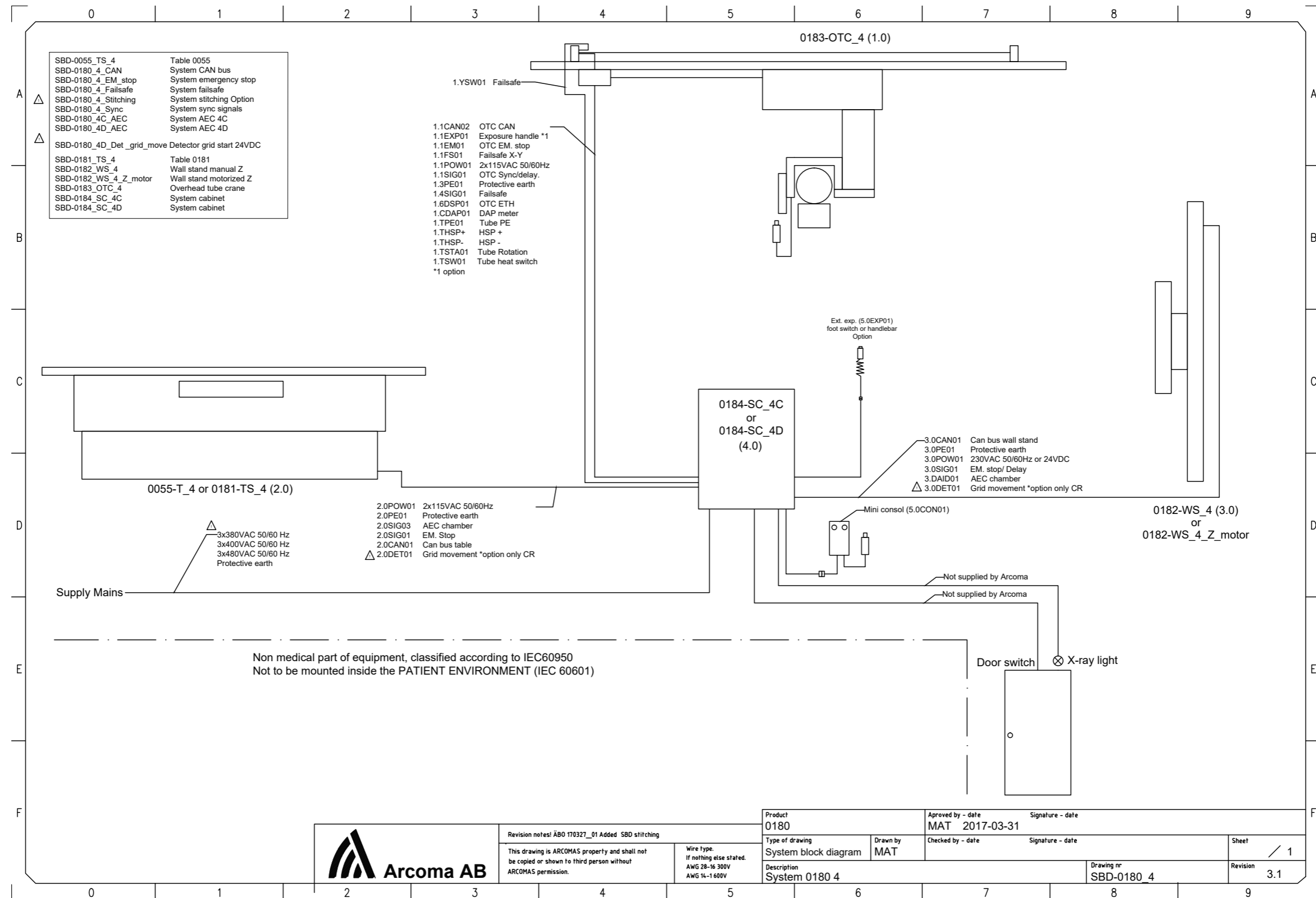

Revision notes! ÅB0 170327\_01 Added SBD stitching

This drawing is ARCOMAS property and shall not be copied or shown to third person without ARCOMAS permission.

Wire type:  
If nothing else stated:  
AWG 28-16 300V  
AWG 14-1 600V

Product 0180	Approved by - date MAT 2017-03-31	Signature - date
Type of drawing System block diagram	Checked by - date	Signature - date
Description System 0180 4		Sheet / 1
Drawing nr SBD-0180_4		Revision 3.1



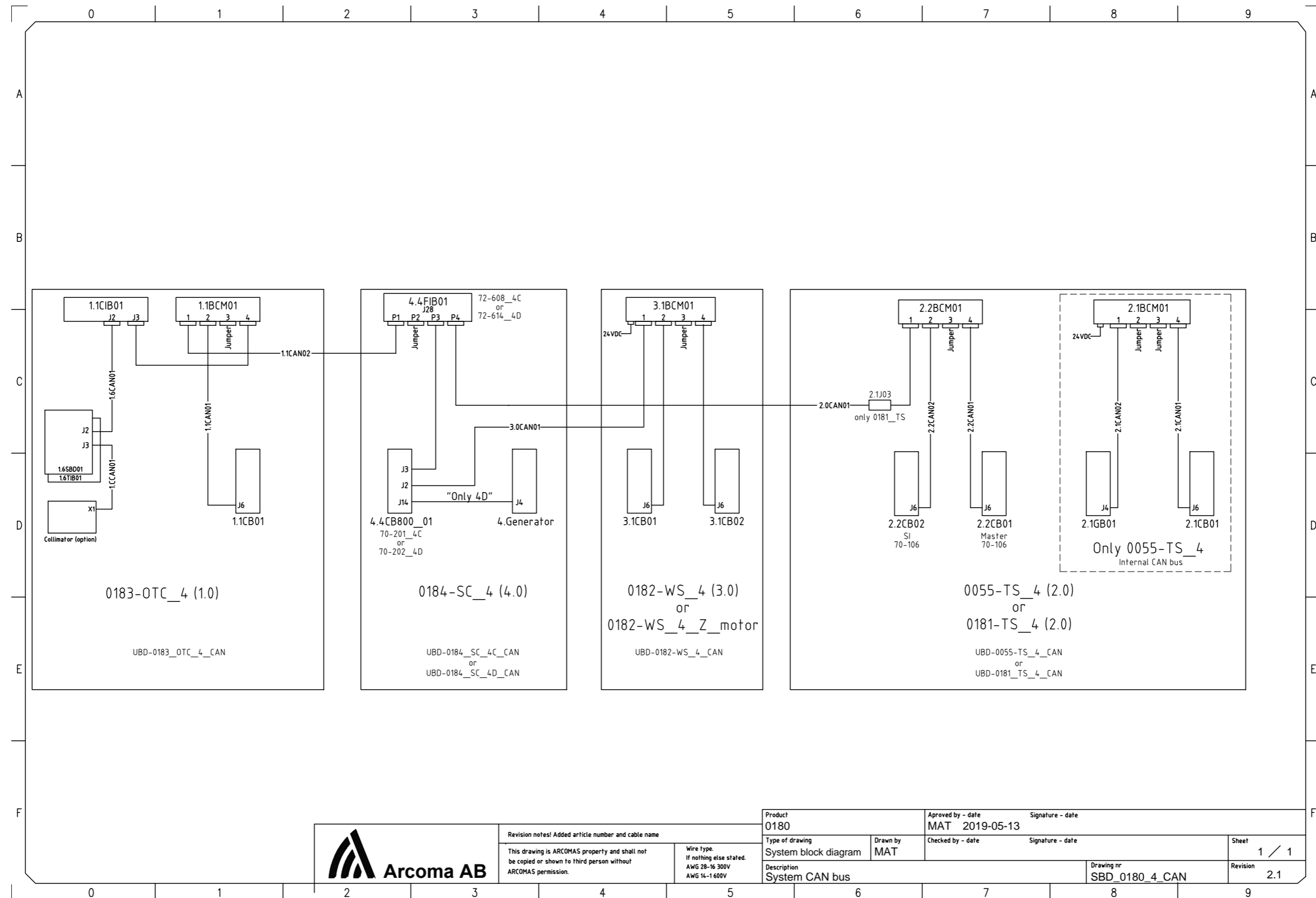

Revision notes! Added article number and cable name

This drawing is ARCOMAS property and shall not be copied or shown to third person without ARCOMAS permission.

Wire type.  
If nothing else stated.  
AWG 28-16 300V  
AWG 14-1 600V

Product <b>0180</b>	Approved by - date <b>MAT 2019-05-13</b>	Signature - date
Type of drawing System block diagram	Drawn by <b>MAT</b>	Checked by - date
Description System CAN bus	Drawing nr <b>SBD_0180_4_CAN</b>	Revision <b>2.1</b>
		Sheet <b>1 / 1</b>



# Electrical drawings

## System block diagram (4C valid for Omnera 400T)

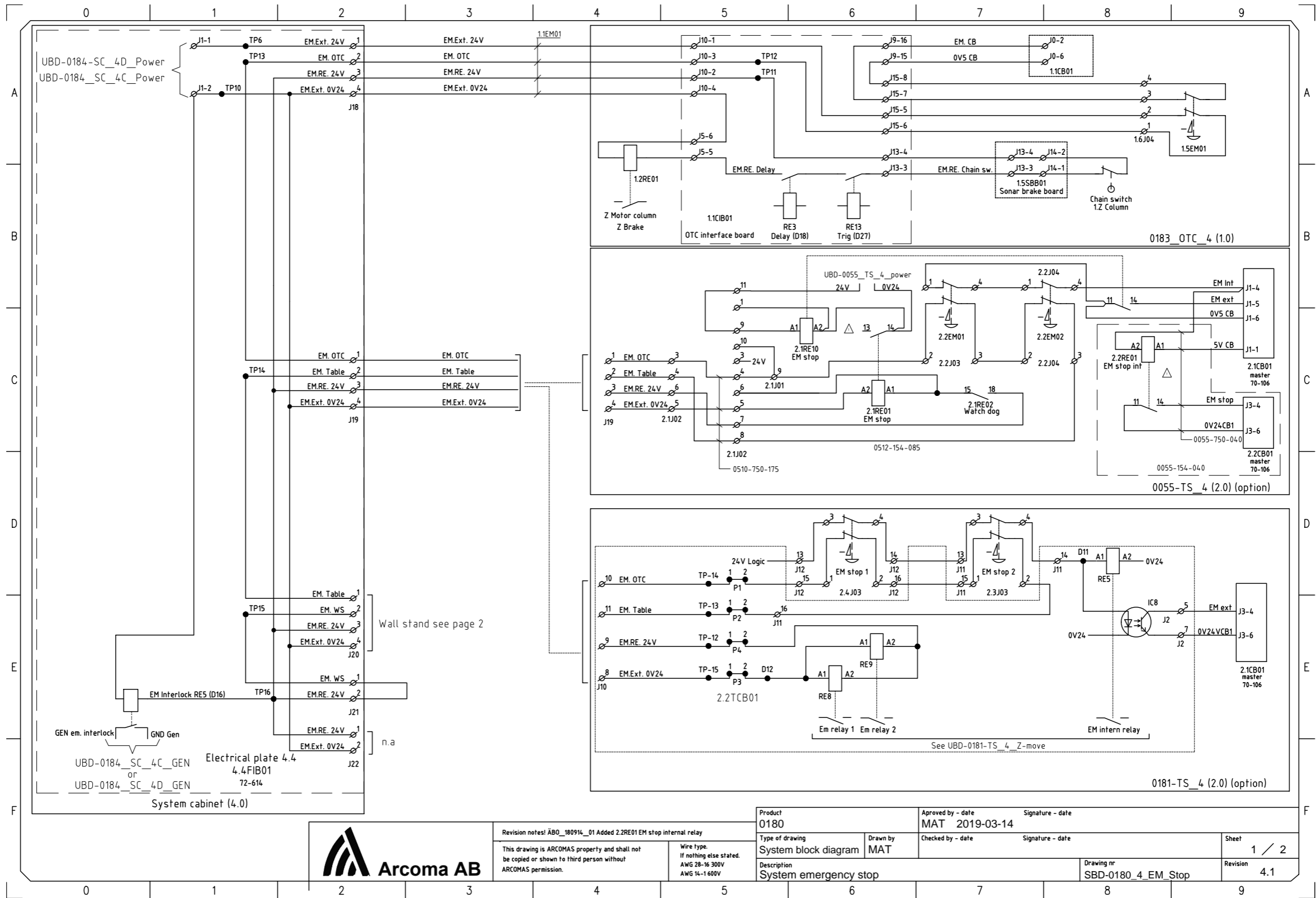

Revision notes! ÅB0\_180914\_01 Added 2.2RE01 EM stop internal relay  
 This drawing is ARCOMAS property and shall not be copied or shown to third person without ARCOMAS permission.  
 Wire type. If nothing else stated. AWG 28-16 300V AWG 14-1 600V

Product 0180	Approved by - date MAT 2019-03-14	Signature - date
Type of drawing System block diagram	Checked by - date	Signature - date
Description System emergency stop		Drawing nr SBD-0180_4_EM_Stop
		Sheet 1 / 2
		Revision 4.1





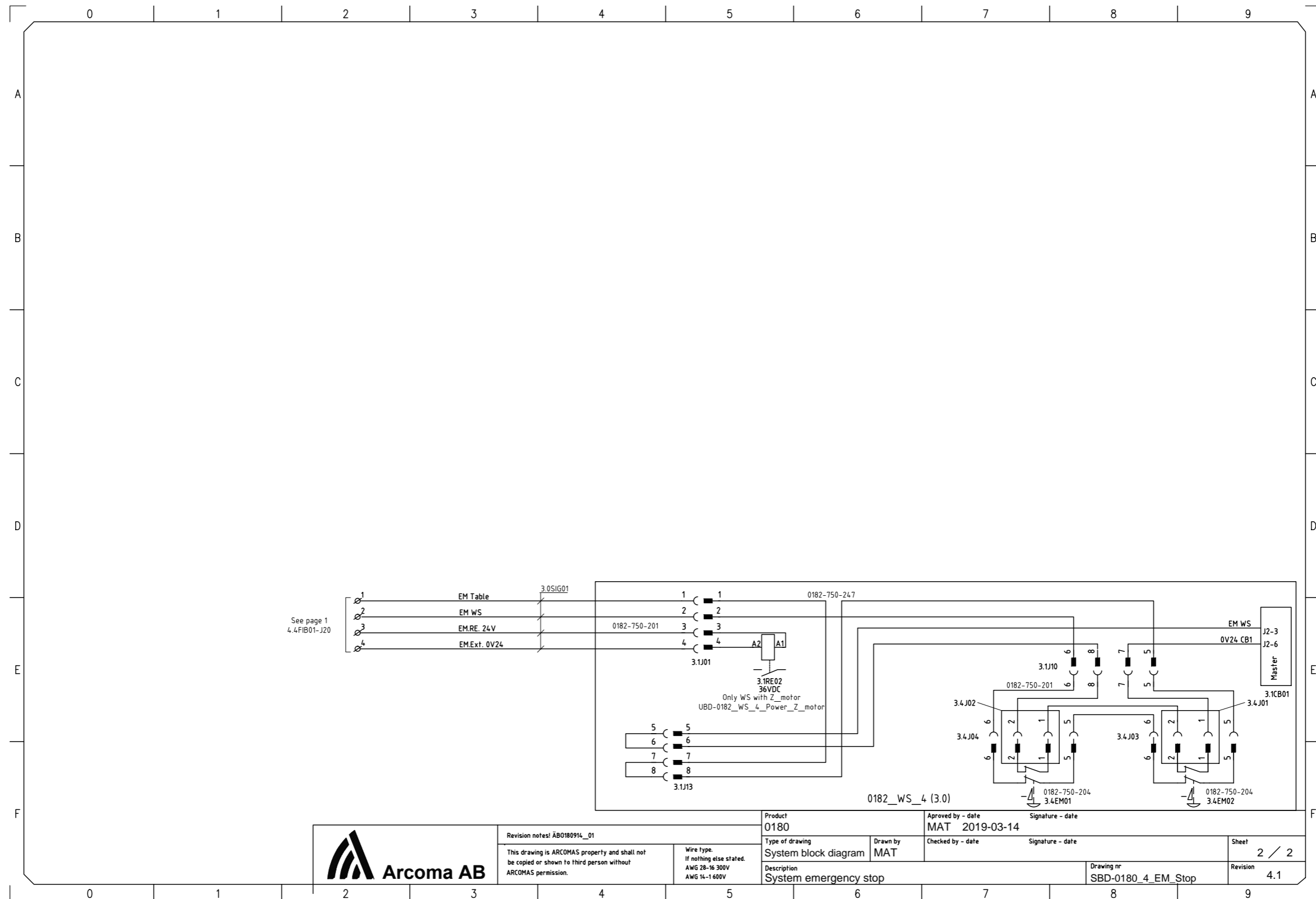

See page 1  
4.4 FIB01-J20



Revision notes! ÅB0180914\_01  
This drawing is ARCOMAS property and shall not be copied or shown to third person without ARCOMAS permission.

Wire type.  
If nothing else stated.  
AWG 28-16 300V  
AWG 14-1 600V

Product  
**0180**  
Type of drawing  
System block diagram  
Description  
System emergency stop

Approved by - date  
**MAT 2019-03-14**  
Checked by - date  
Signature - date

Signature - date  
Drawing nr  
**SBD-0180\_4\_EM\_Stop**

Sheet  
**2 / 2**  
Revision  
**4.1**



# Electrical drawings

## System block diagram (4C valid for Omnera 400T)

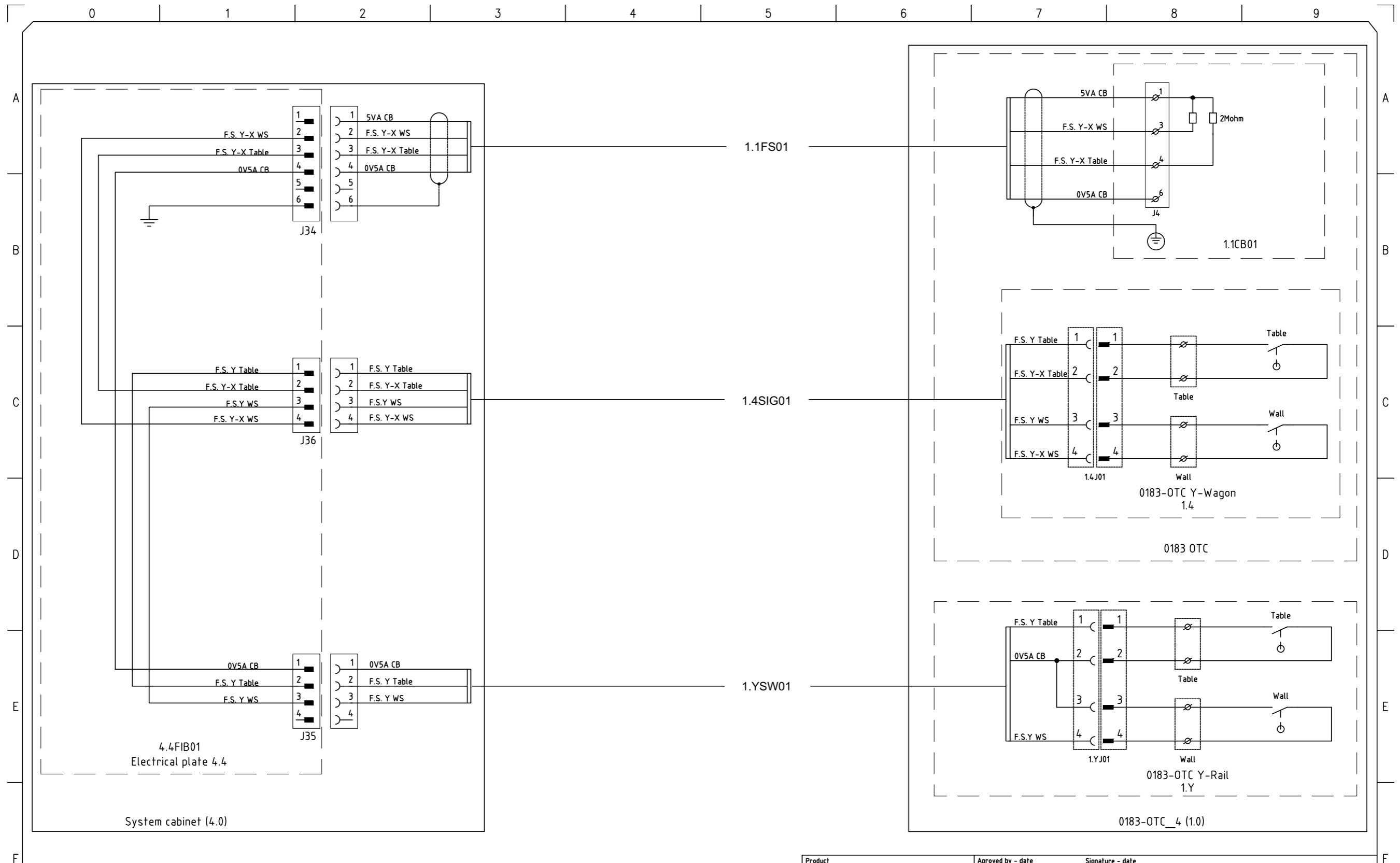

Revision notes!  
 This drawing is ARCOMAS property and shall not be copied or shown to third person without ARCOMAS permission.  
 Wire type:  
 If nothing else stated:  
 AWG 28-16 300V  
 AWG 14-1 600V

Product 0180		Approved by - date MAT 2017-03-14		Signature - date	
Type of drawing System block diagram	Drawn by MAT	Checked by - date		Signature - date	
Description System fail safe switches			Drawing nr SBD-0180_4_Failsafe		Sheet 1 / 1
					Revision 1.1



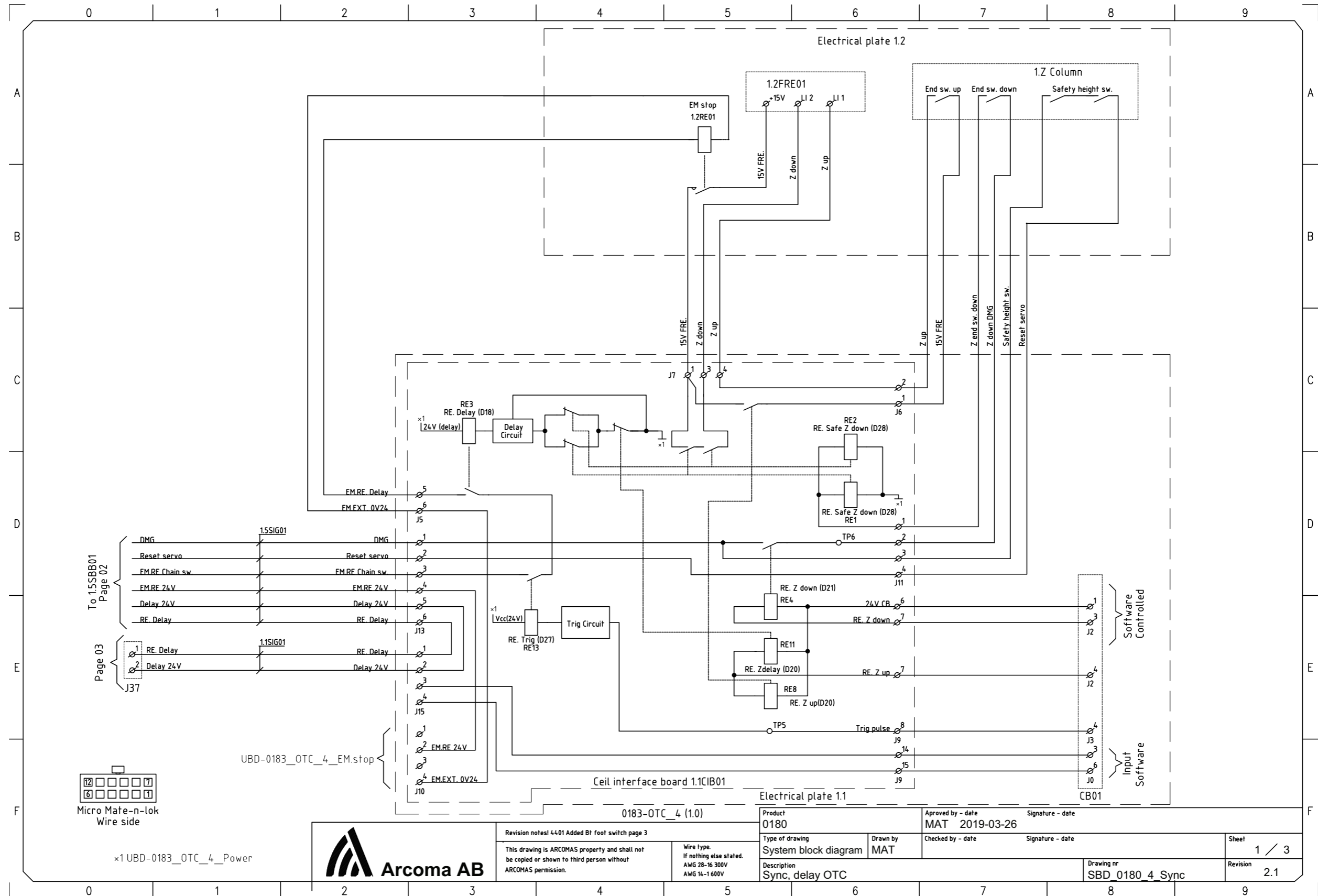

To 1.5SBB01  
Page 02

Page 03

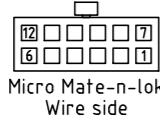

x1 UBD-0183\_OTC\_4\_Power



Revision notes! 4401 Added Bf foot switch page 3

This drawing is ARCOMAS property and shall not be copied or shown to third person without ARCOMAS permission.

Wire type:  
If nothing else stated:  
AWG 28-16 300V  
AWG 14-1 600V

Product 0180		Approved by - date MAT 2019-03-26		Signature - date	
Type of drawing System block diagram		Drawn by MAT		Checked by - date	
Description Sync, delay OTC		Drawing nr SBD_0180_4_Sync		Sheet 1 / 3	
				Revision 2.1	



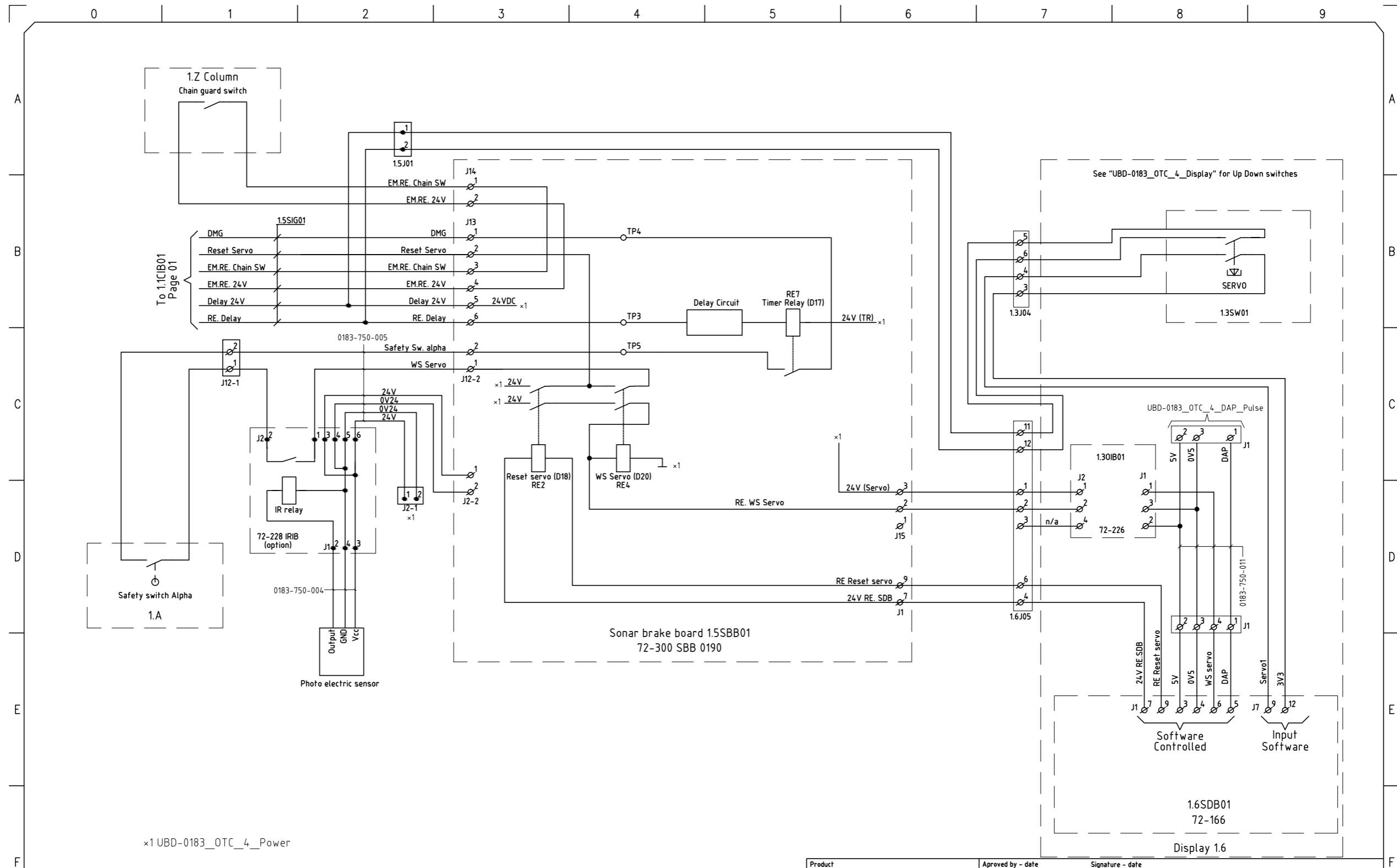

x1 UBD-0183\_OTC\_4\_Power

	Revision notes:		Product	Approved by - date		Signature - date	
	This drawing is ARCOMAS property and shall not be copied or shown to third person without ARCOMAS permission.		Wire type: If nothing else stated: AWG 28-16 300V AWG 14-1600V	0180	MAT 2019-03-26		
			Type of drawing	Drawn by	Checked by - date	Signature - date	
			System block diagram	MAT			Sheet
			Description	Drawing nr			Revision
			Sync, delay, IR OTC	SBD_0180_4_Sync			2 / 3
							2.1





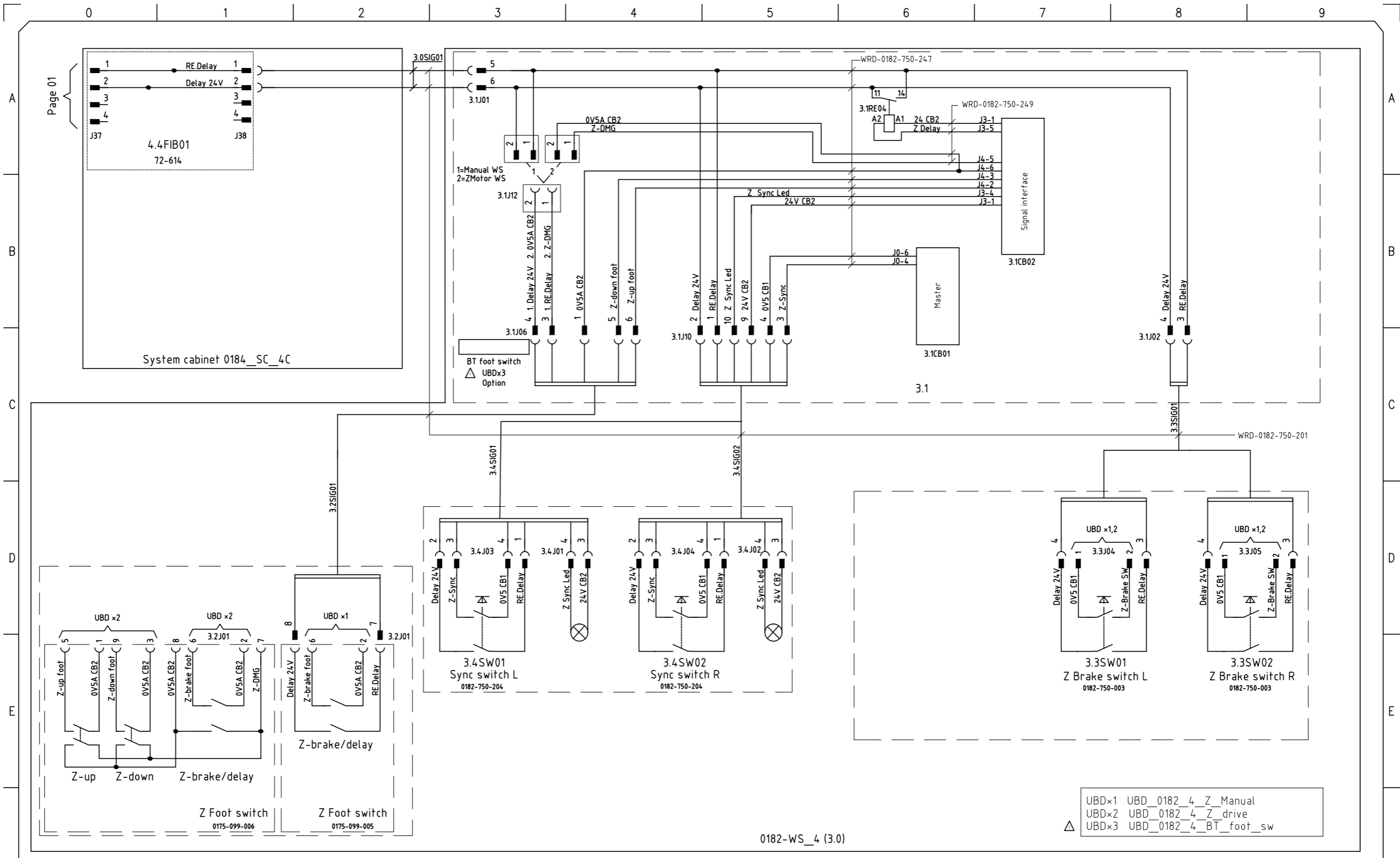

Revision notes! 4411 Addet BT foot switch

This drawing is ARCOMAS property and shall not be copied or shown to third person without ARCOMAS permission.

Wire type.  
If nothing else stated.  
AWG 28-16 300V  
AWG 14-1600V

Product 0180		Approved by - date 2019-03-26		Signature - date	
Type of drawing System block diagram		Drawn by MAT		Checked by - date	
Description Sync wallstand and system cabinet				Drawing nr SBD_0180_4_Sync	
					Sheet 3 / 3
					Revision 2.1







# Electrical drawings

## System block diagram (4C valid for Omnera 400T)

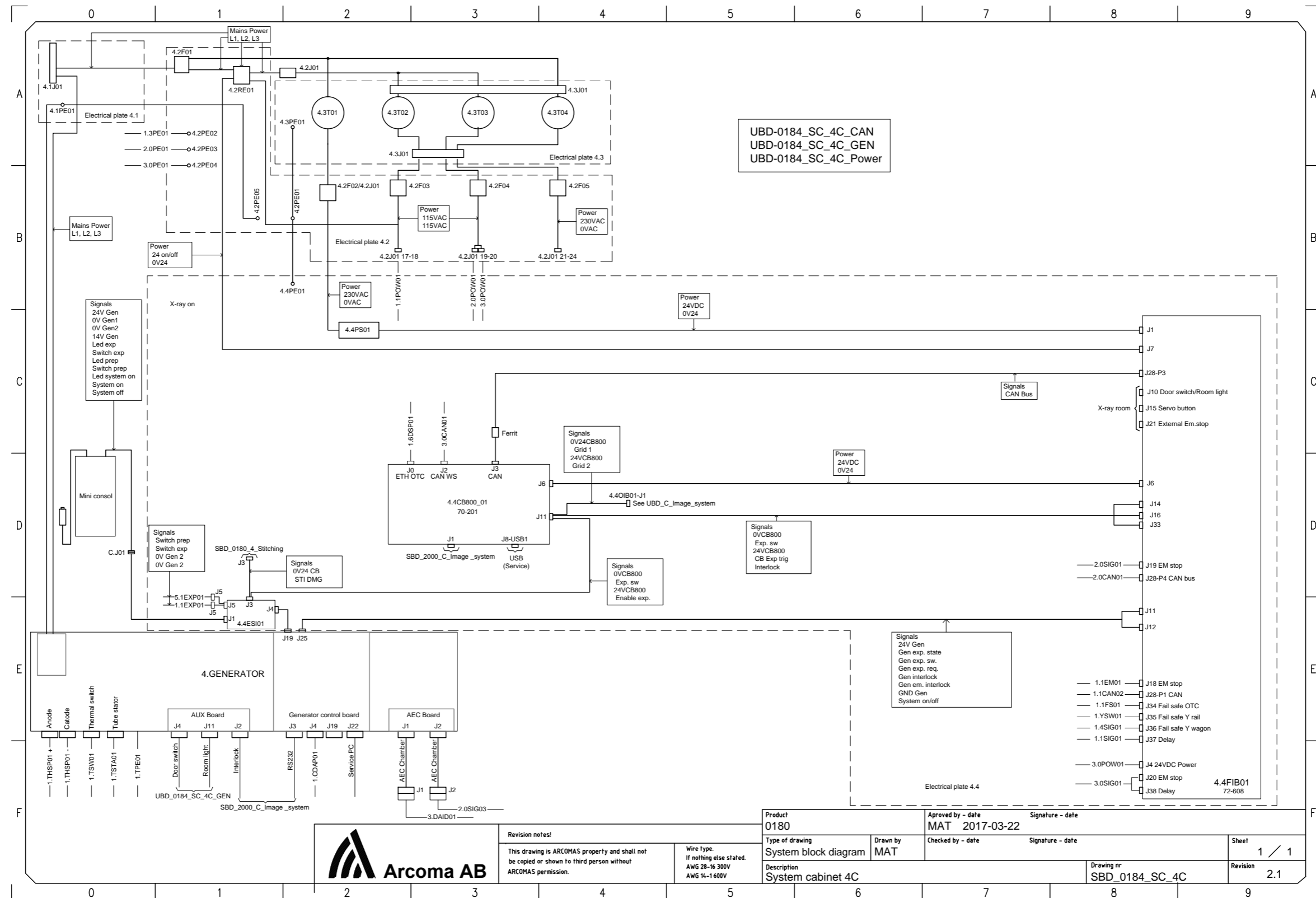

**Revision notes!**  
 This drawing is ARCOMAS property and shall not be copied or shown to third person without ARCOMAS permission.

**Wire type.**  
 If nothing else stated.  
 AWG 28-16 300V  
 AWG 14-1 600V

Product <b>0180</b>		Approved by - date <b>MAT 2017-03-22</b>		Signature - date	
Type of drawing System block diagram		Checked by - date		Signature - date	
Description System cabinet 4C		Drawing nr SBD_0184_SC_4C		Sheet 1 / 1	
				Revision 2.1	



# Electrical drawings

## System block diagram (4C valid for Omnera 400T)

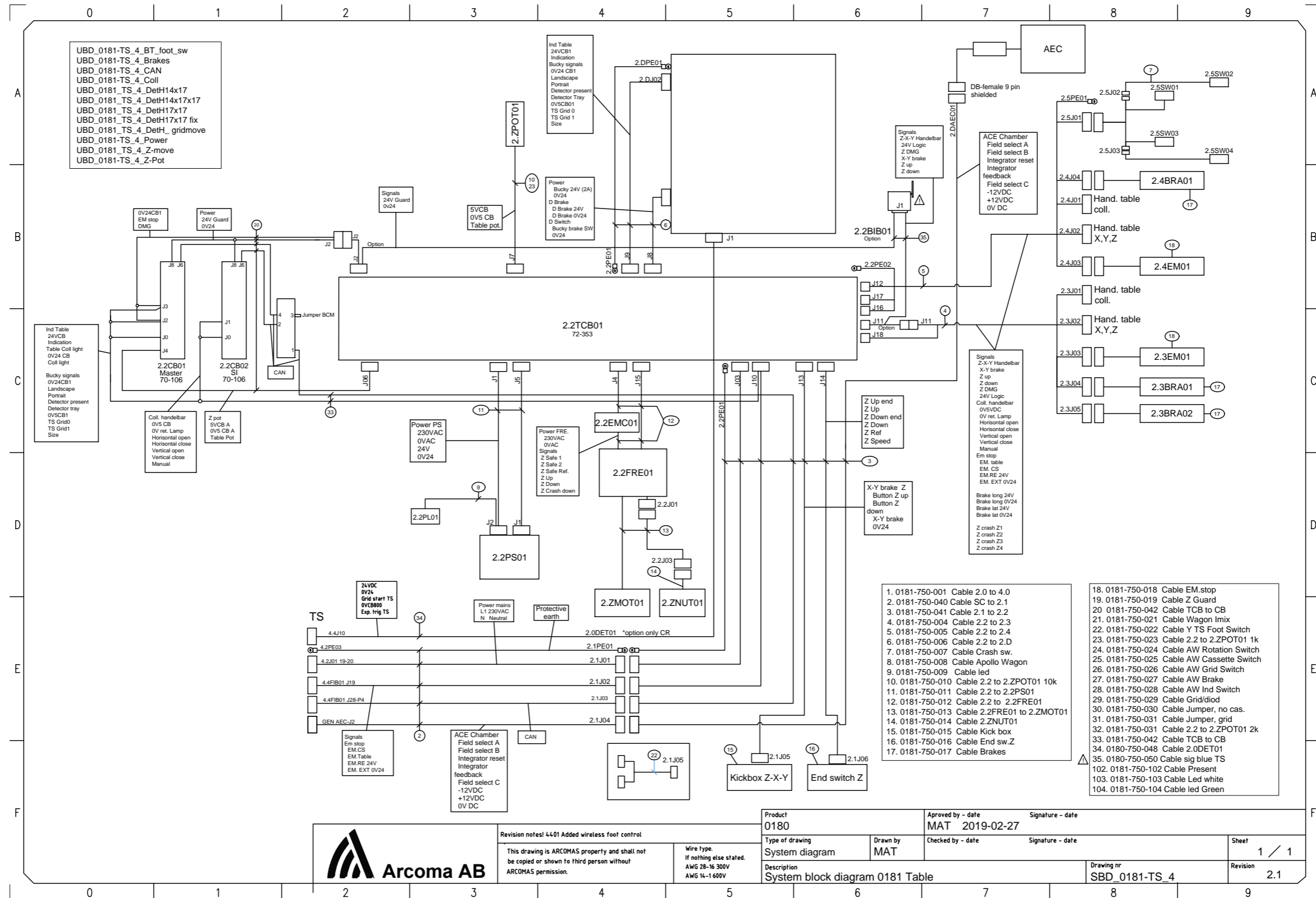

Revision notes! 4401 Added wireless foot control  
 This drawing is ARCOMAS property and shall not be copied or shown to third person without ARCOMAS permission.

Product <b>0180</b>	Approved by - date <b>MAT 2019-02-27</b>	Signature - date
Type of drawing System diagram	Checked by - date	Signature - date
Description System block diagram 0181 Table	Drawing nr <b>SBD_0181-TS_4</b>	Sheet 1 / 1
Revision 2.1		





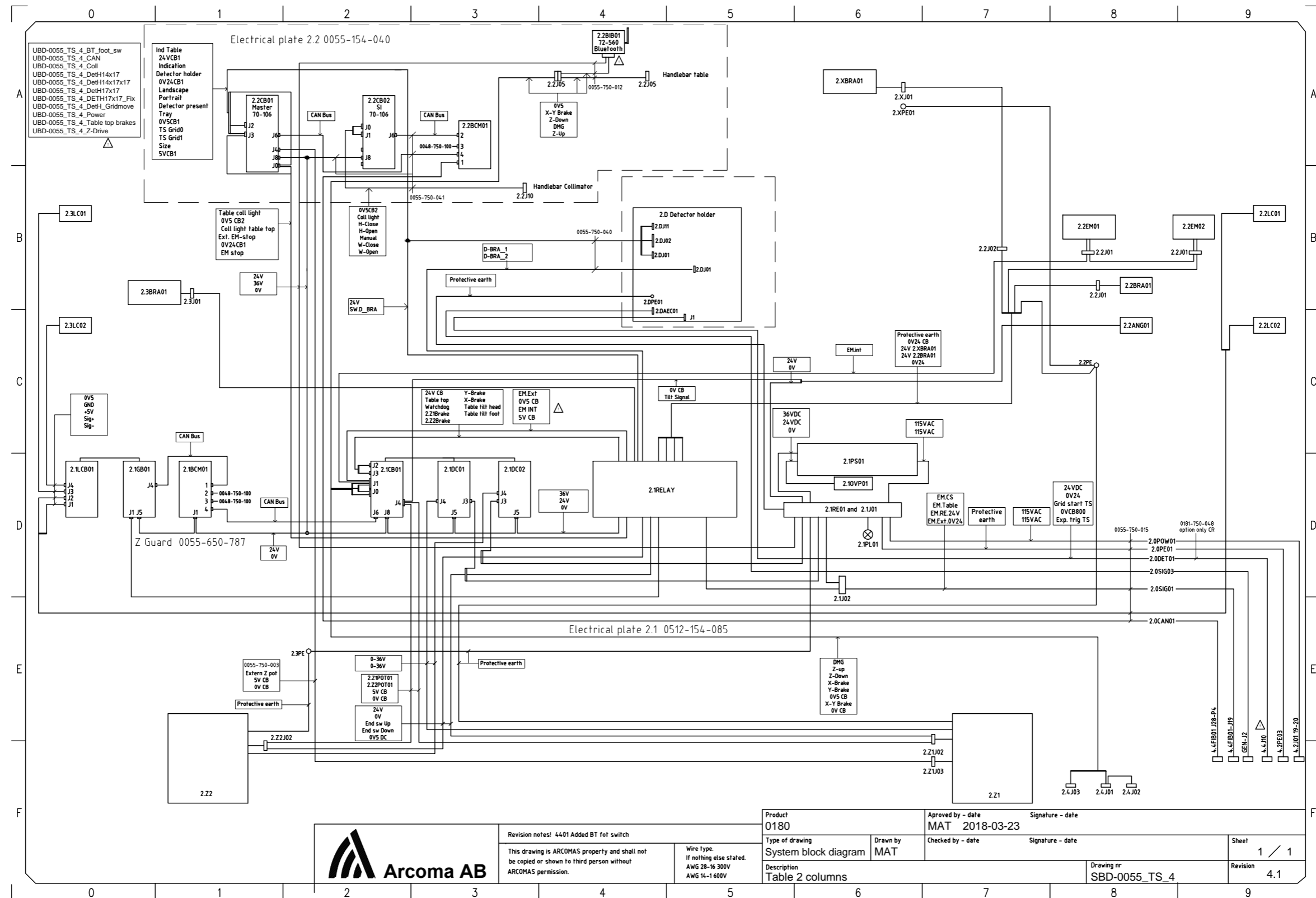

Revision notes! 4401 Added BT for switch  
 This drawing is ARCOMAS property and shall not be copied or shown to third person without ARCOMAS permission.  
 Wire type:  
 If nothing else stated:  
 AWG 28-16 300V  
 AWG 14-1 600V

Product 0180	Approved by - date MAT 2018-03-23	Signature - date
Type of drawing System block diagram	Checked by - date	Signature - date
Drawn by MAT		
Description Table 2 columns	Drawing nr SBD-0055_TS_4	Sheet 1 / 1
		Revision 4.1



# Electrical drawings

## System block diagram (4C valid for Omnera 400T)

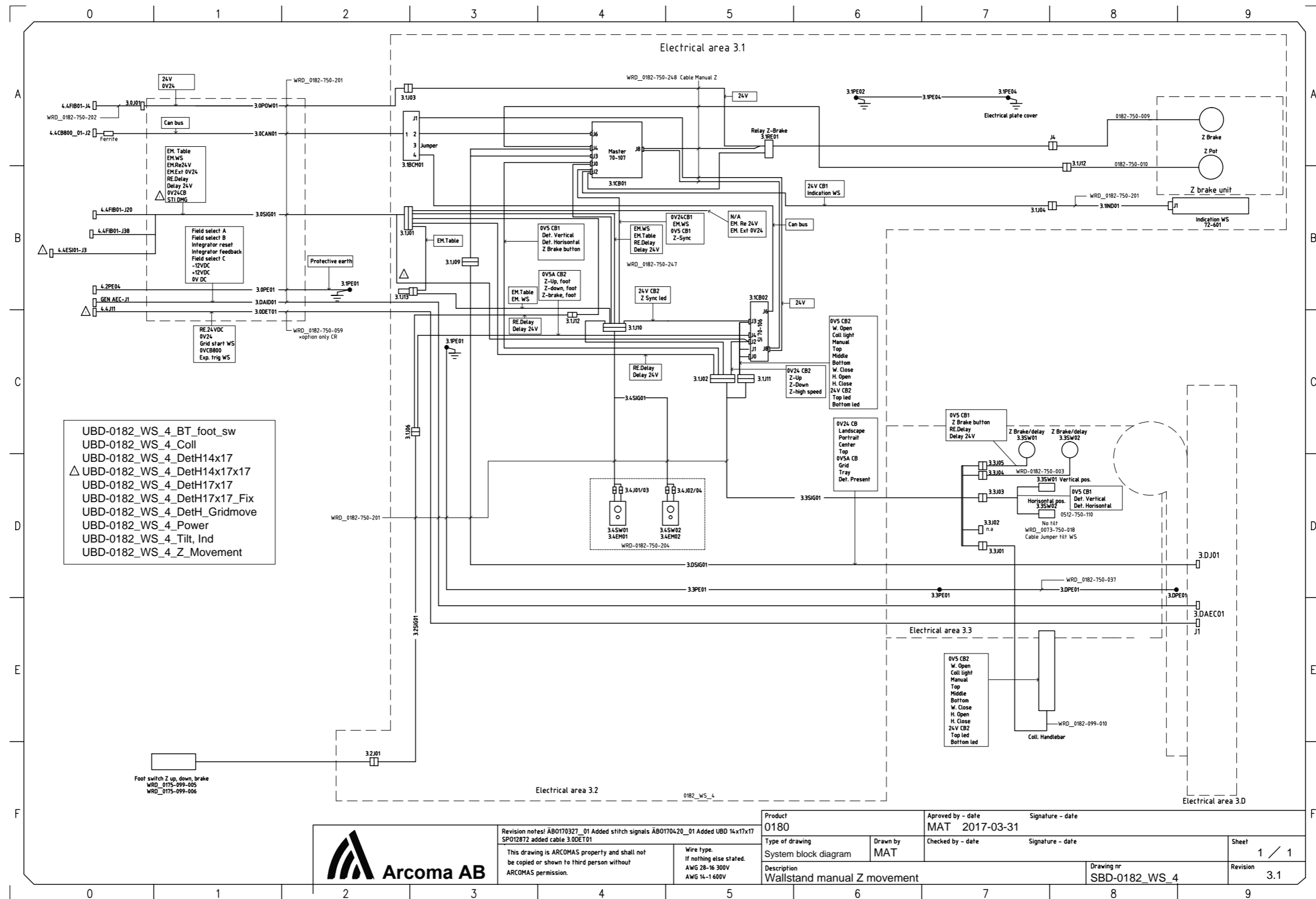



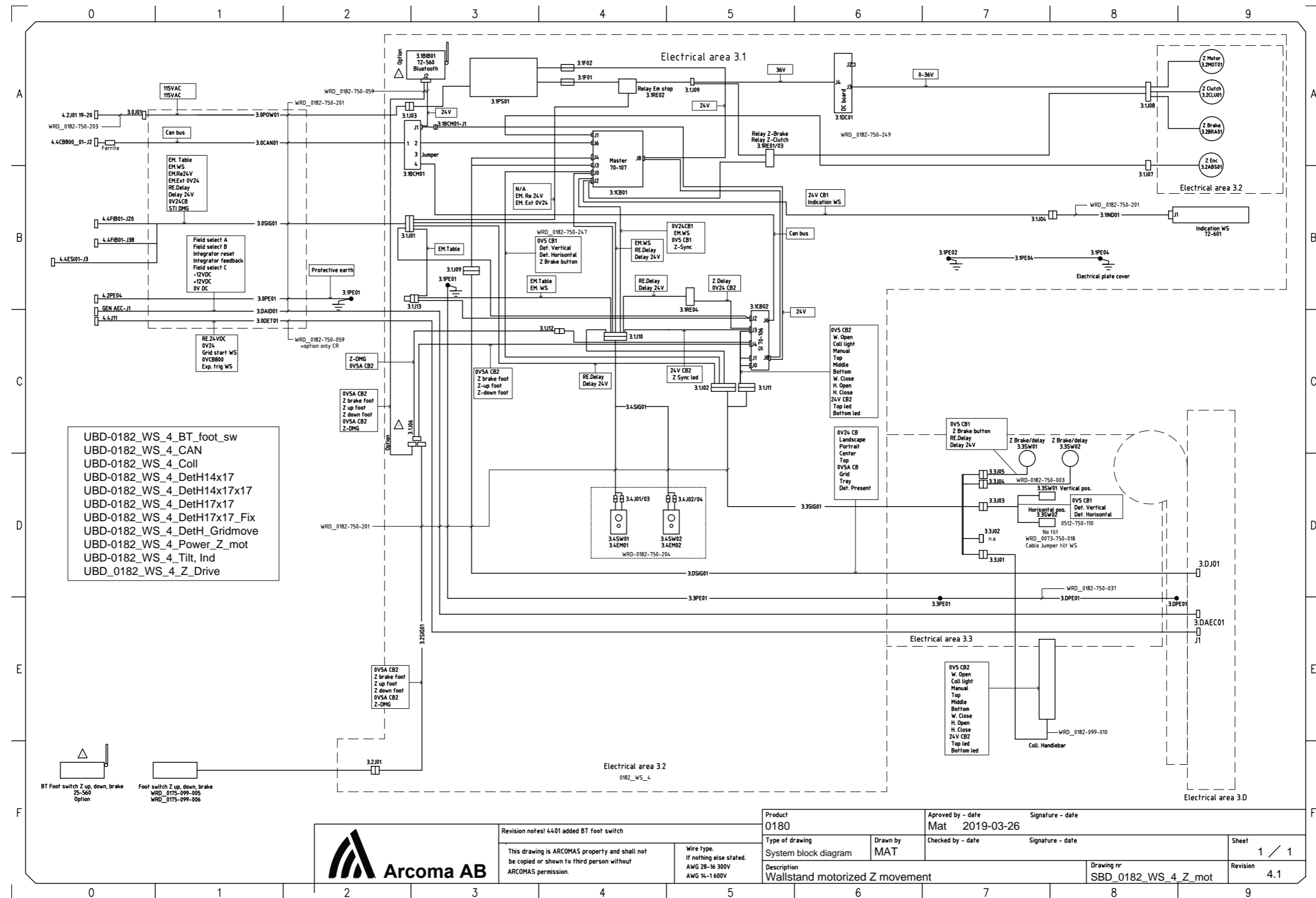



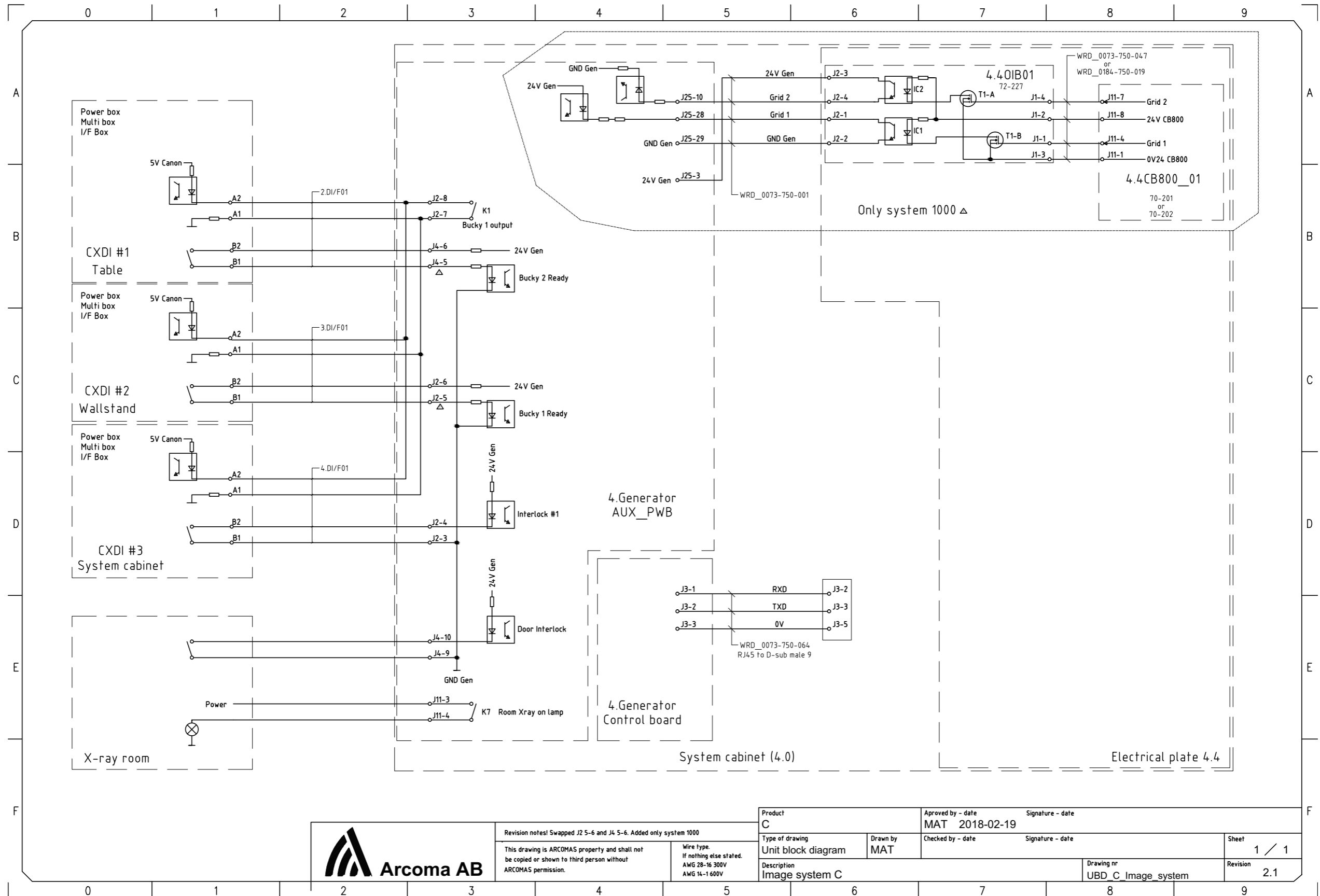

Revision notes! Swapped J2 5-6 and J4 5-6. Added only system 1000  
 This drawing is ARCOMAS property and shall not be copied or shown to third person without ARCOMAS permission.  
 Wire type:  
 If nothing else stated:  
 AWG 28-16 300V  
 AWG 14-1 600V

Product C		Approved by - date MAT 2018-02-19		Signature - date	
Type of drawing Unit block diagram	Drawn by MAT	Checked by - date		Signature - date	
Description Image system C			Drawing nr UBD_C Image system		Sheet 1 / 1
					Revision 2.1





# Electrical drawings

## Unit block diagram (4C valid for Omnera 400T)

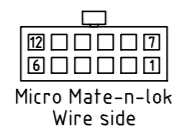
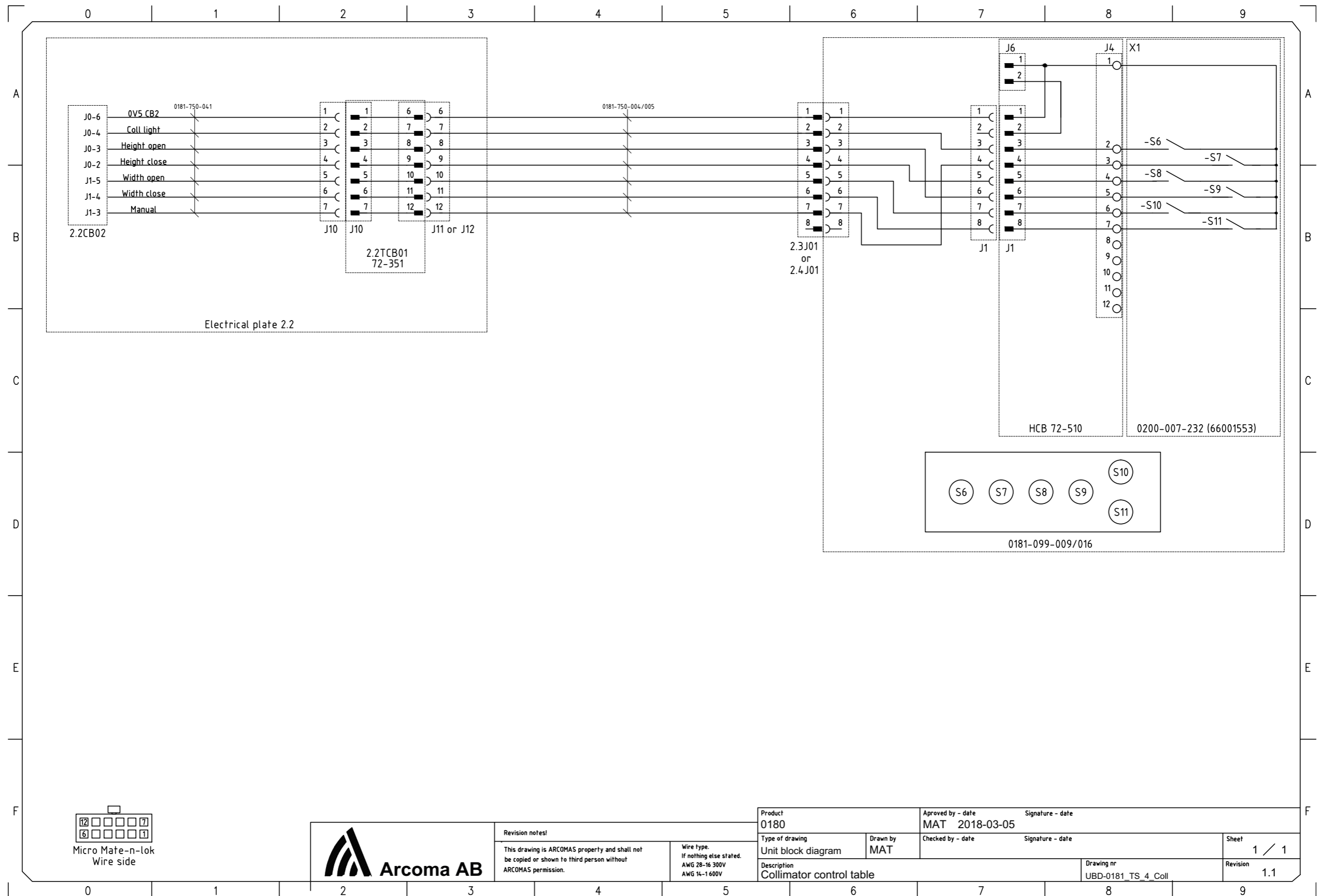

Revision notes!  
This drawing is ARCOMAS property and shall not be copied or shown to third person without ARCOMAS permission.

Wire type.  
If nothing else stated.  
AWG 28-16 300V  
AWG 14-1600V

Product 0180		Approved by - date MAT 2018-03-05		Signature - date	
Type of drawing Unit block diagram	Drawn by MAT	Checked by - date		Signature - date	
Description Collimator control table				Drawing nr UBD-0181_TS_4_Coll	Sheet 1 / 1
				Revision 1.1	



# Electrical drawings

## Unit block diagram (4C valid for Omnera 400T)

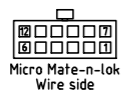
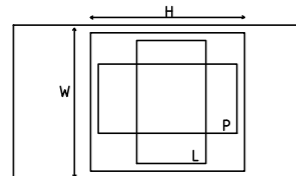
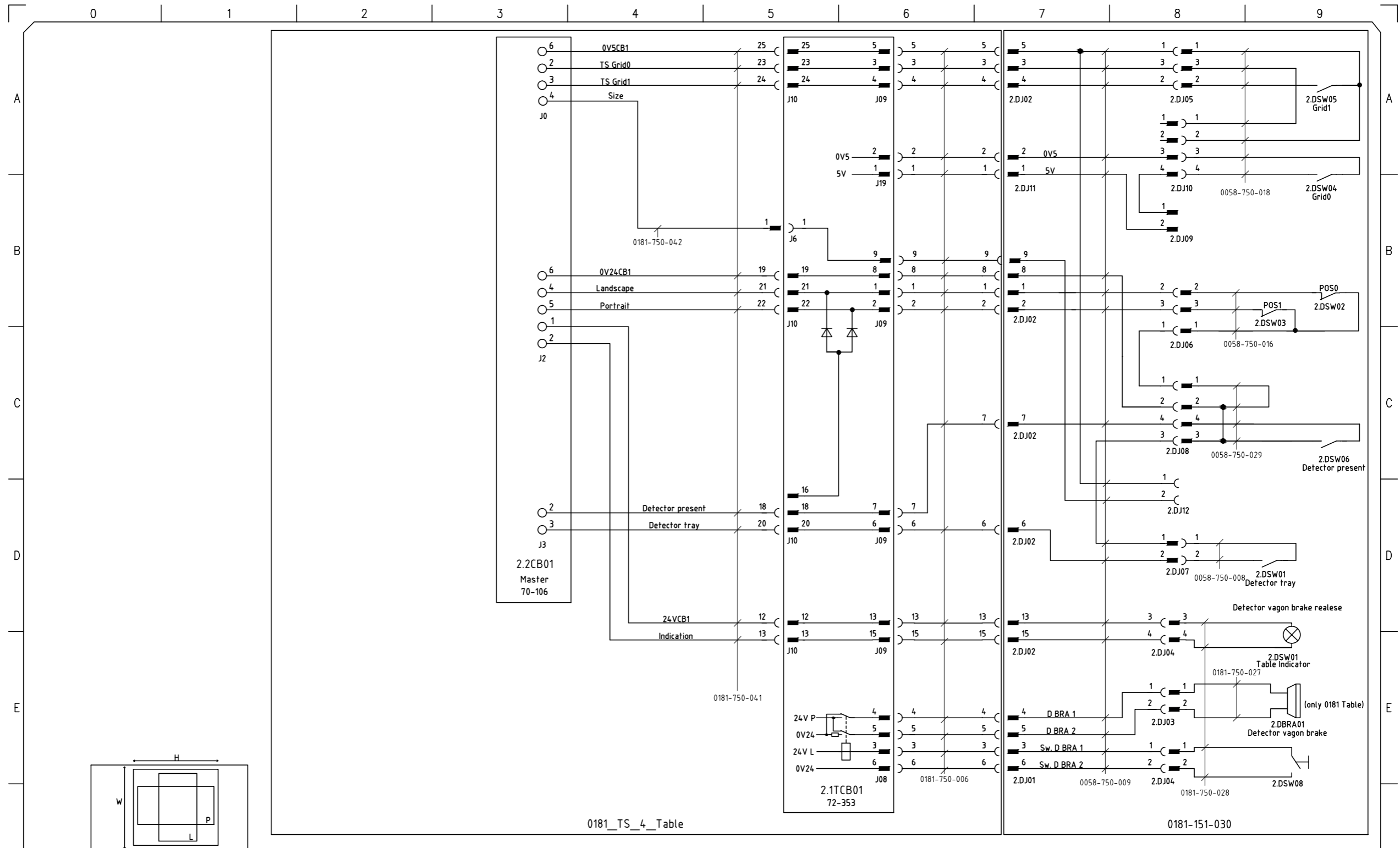

Revision notes:  
 This drawing is ARCOMAS property and shall not be copied or shown to third person without ARCOMAS permission.  
 Wire type:  
 If nothing else stated:  
 AWG 28-16 300V  
 AWG 14-1 600V

Product 0180	Approved by - date MAT 2018-03-05	Signature - date
Type of drawing Unit block diagram	Drawn by MAT	Checked by - date
Description Detector holder 14x17 Table		Signature - date
Drawing nr UBD_0181_TS_4_DetH14x17		Sheet 1 / 1
Revision 1.1		



# Electrical drawings

## Unit block diagram (4C valid for Omnera 400T)

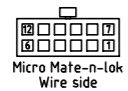
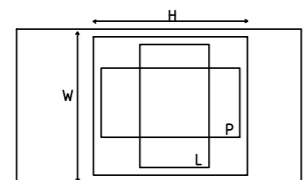
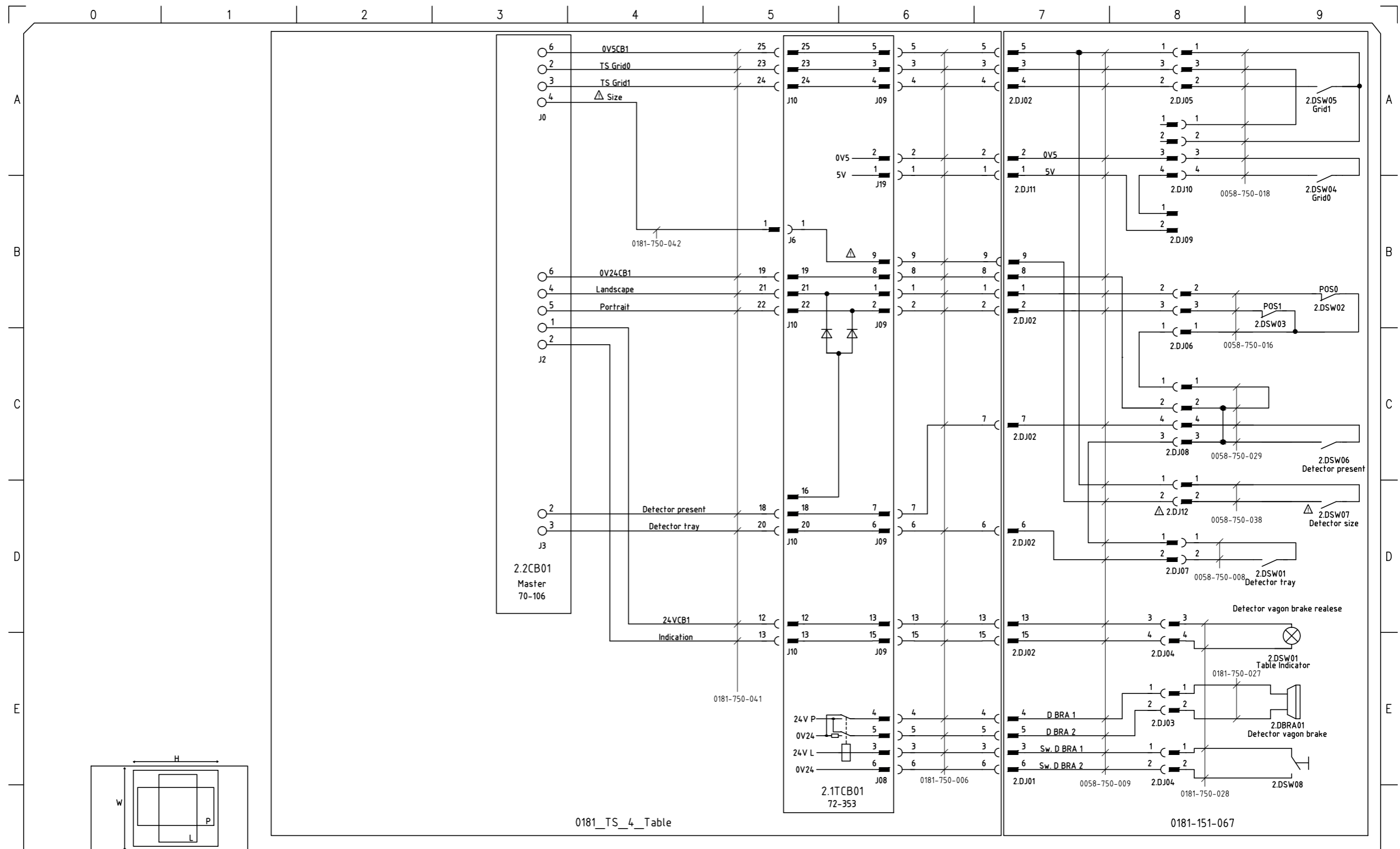

Revision notes! ÅB0170420\_01  
 This drawing is ARCOMAS property and shall not be copied or shown to third person without ARCOMAS permission.  
 Wire type:  
 If nothing else stated:  
 AWG 28-16 300V  
 AWG 14-1600V

Product 0180	Approved by - date MAT 2017-04-26	Signature - date
Type of drawing Unit block diagram	Drawn by MAT	Checked by - date
Description Detector holder 14x17 or 17x17 Table		Signature - date
Drawing nr UBD_0181_TS_4_DetH14x17x17		Sheet 1 / 1
Revision 1.1		



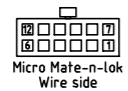
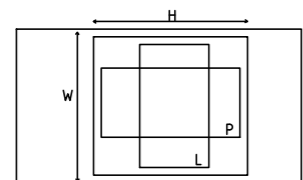
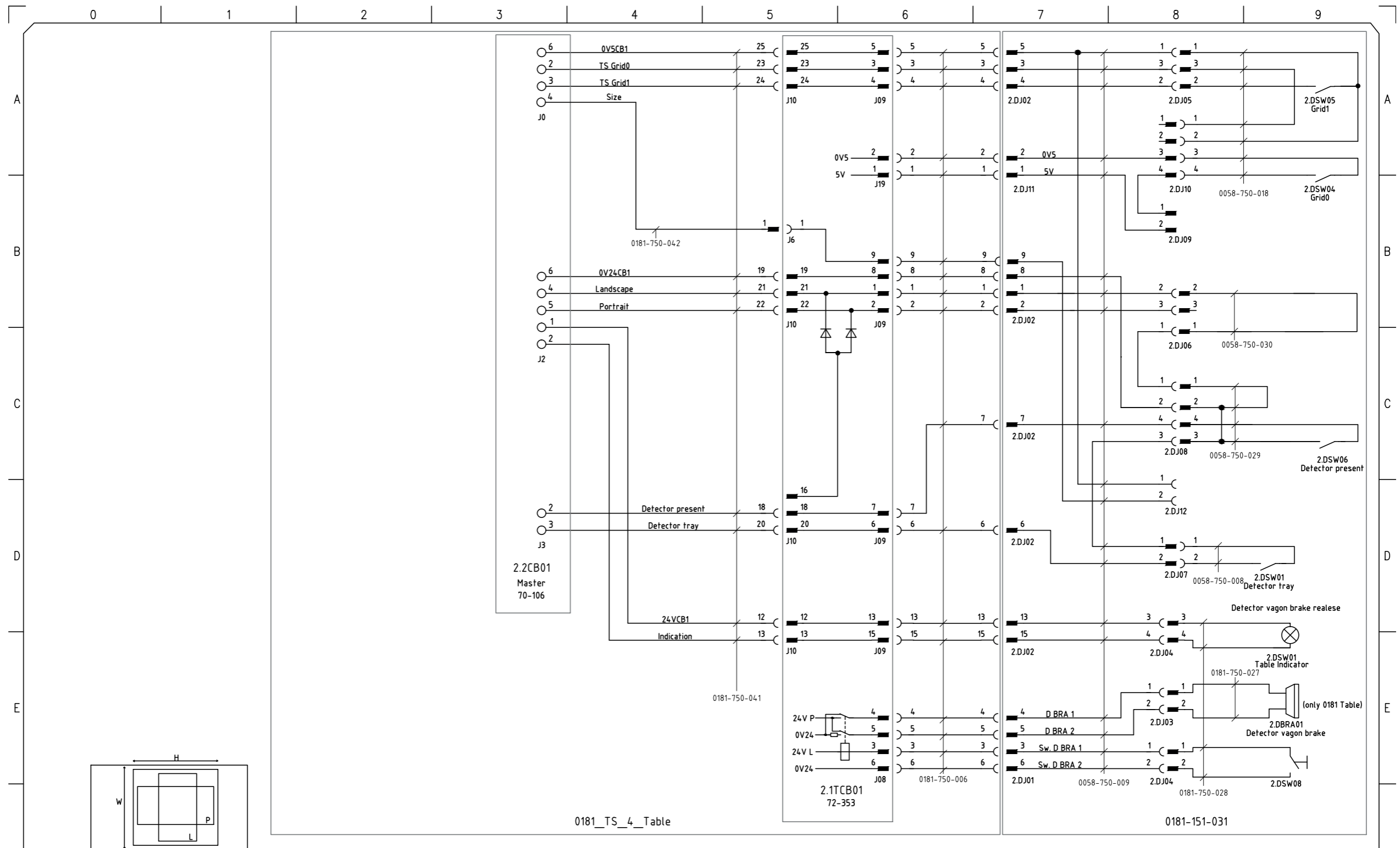

**Revision notes!**  
 This drawing is ARCOMAS property and shall not be copied or shown to third person without ARCOMAS permission.

**Wire type:**  
 If nothing else stated:  
 AWG 28-16 300V  
 AWG 14-1 600V

Product <b>0180</b>	Approved by - date <b>MAT 2018-03-05</b>	Signature - date
Type of drawing <b>Unit block diagram</b>	Drawn by <b>MAT</b>	Checked by - date
Description <b>Detector holder 17x17 Table</b>		Sheet <b>1 / 1</b>
Drawing nr <b>UBD_0181_TS_4_DetH17x17</b>		Revision <b>1.1</b>





# Electrical drawings

## Unit block diagram (4C valid for Omnera 400T)

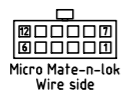
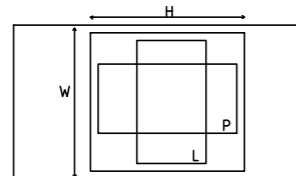
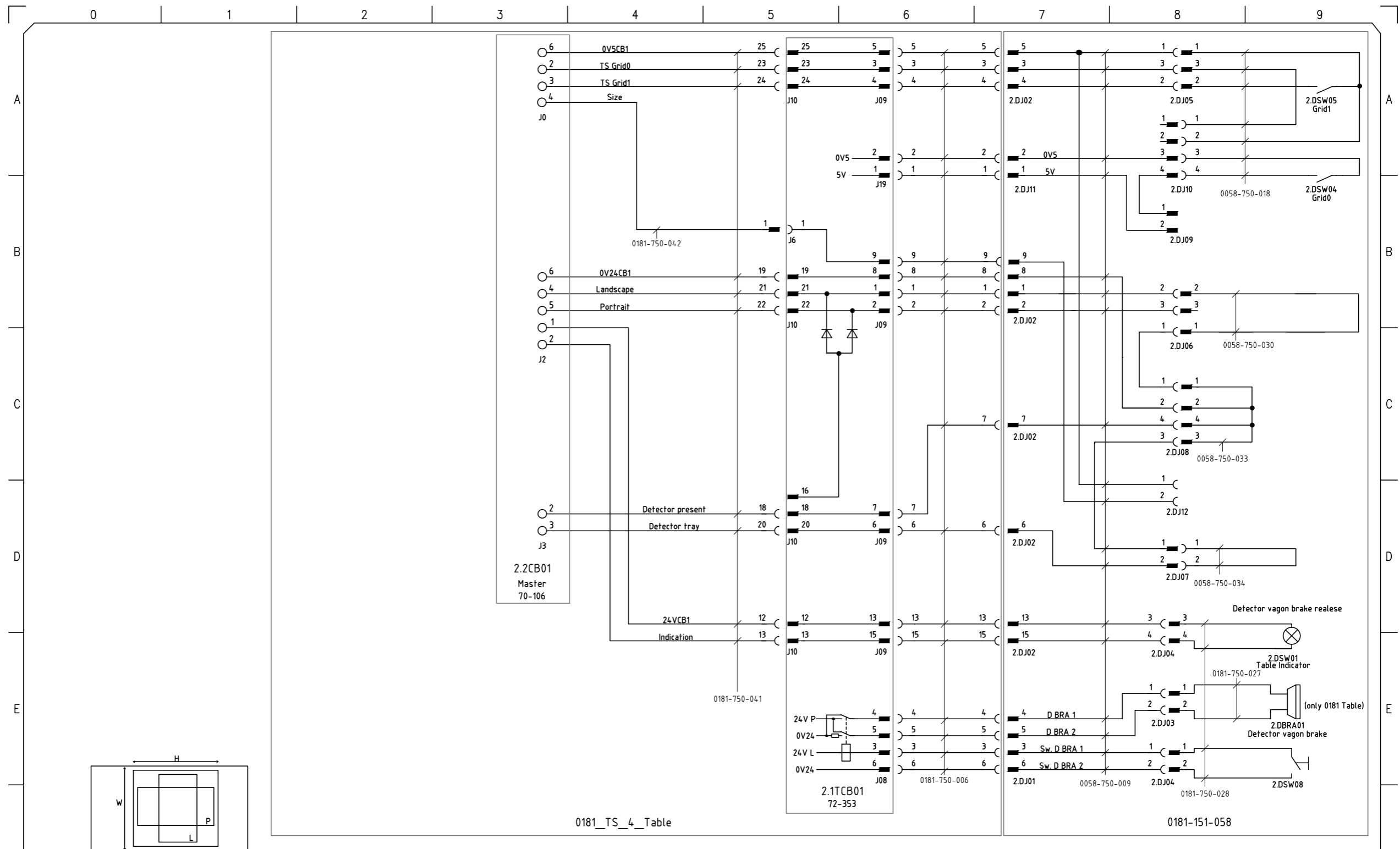

**Revision notes:**  
 This drawing is ARCOMAS property and shall not be copied or shown to third person without ARCOMAS permission.

**Wire type:**  
 If nothing else stated:  
 AWG 28-16 300V  
 AWG 14-1 600V

Product 0180	Approved by - date MAT 2018-03-05	Signature - date
Type of drawing Unit block diagram	Drawn by MAT	Checked by - date
Description Detector holder 17x17_fixed Table		Sheet 1 / 1
Drawing nr UBD_0181_TS_4_DetH17x17_Fixed		Revision 1.1



# Electrical drawings

## Unit block diagram (4C valid for Omnera 400T)

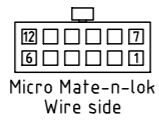
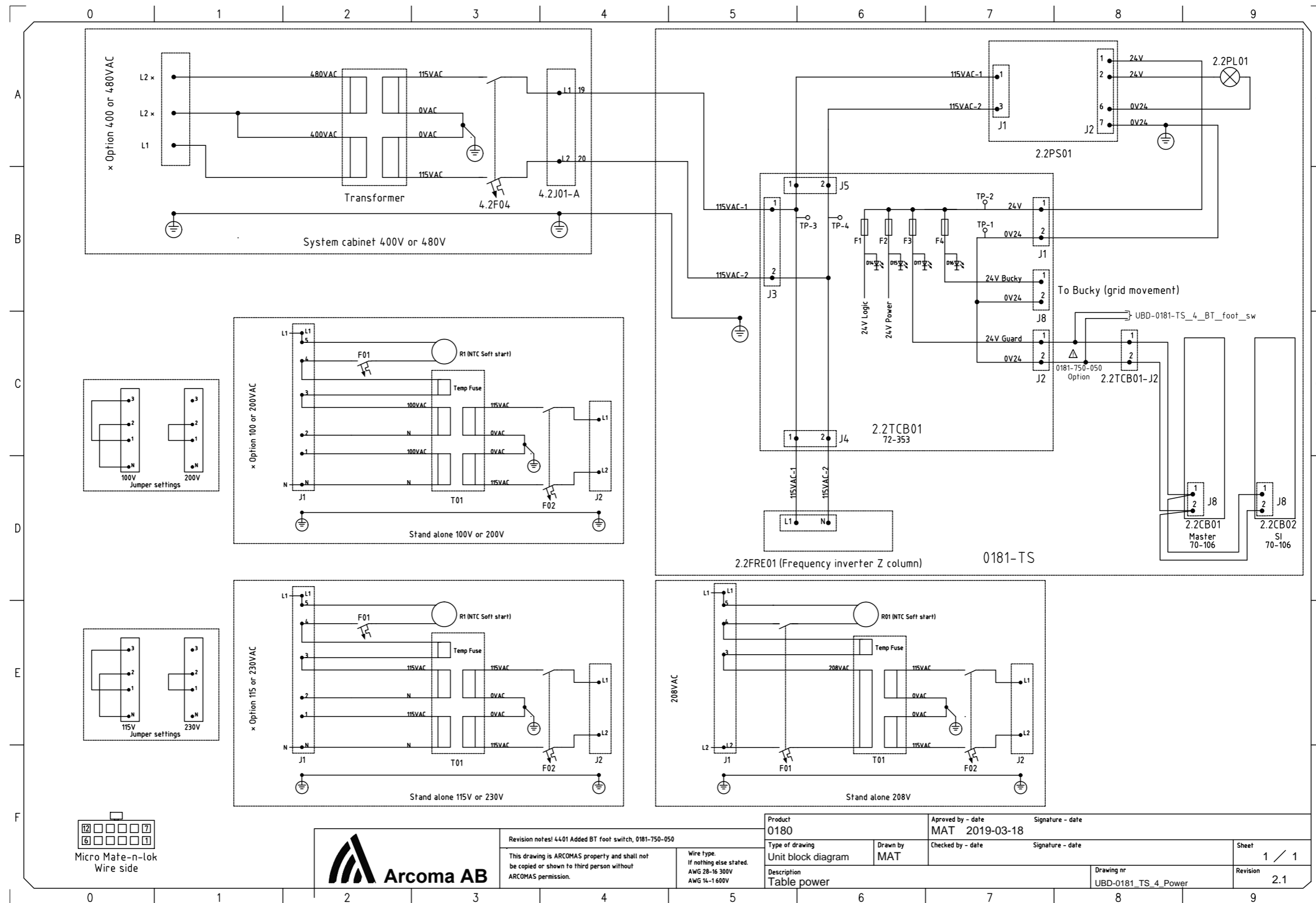

Revision notes! 4.01 Added BT foot switch, 0181-750-050

This drawing is ARCOMAS property and shall not be copied or shown to third person without ARCOMAS permission.

Wire type:  
If nothing else stated:  
AWG 28-16 300V  
AWG 14-1 600V

Product <b>0180</b>	Approved by - date <b>MAT 2019-03-18</b>	Signature - date
Type of drawing Unit block diagram	Checked by - date	Signature - date
Drawn by <b>MAT</b>		
Description Table power	Drawing nr UBD-0181 TS_4_Power	Sheet 1 / 1
		Revision 2.1



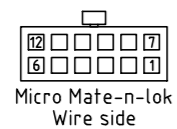
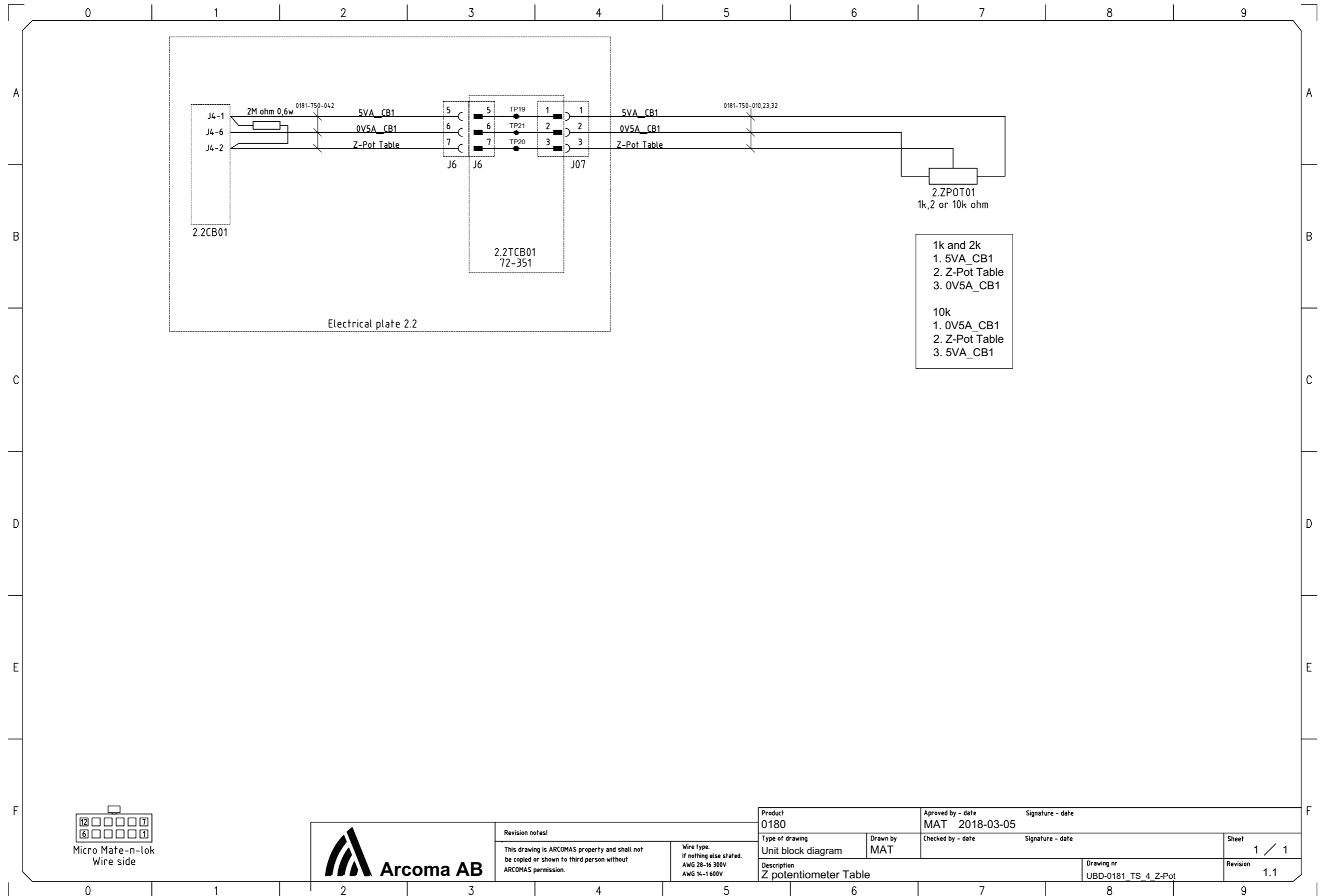

**Revision notes!**  
This drawing is ARCOMAS property and shall not be copied or shown to third person without ARCOMAS permission.

**Wire type.**  
If nothing else stated.  
AWG 28-16 300V  
AWG 14-1 600V

Product 0180		Approved by - date MAT 2018-03-05		Signature - date	
Type of drawing Unit block diagram	Drawn by MAT	Checked by - date		Signature - date	
Description Z potentiometer Table				Drawing nr UBD-0181_TS_4_Z-Pot	Sheet 1 / 1
				Revision 1.1	



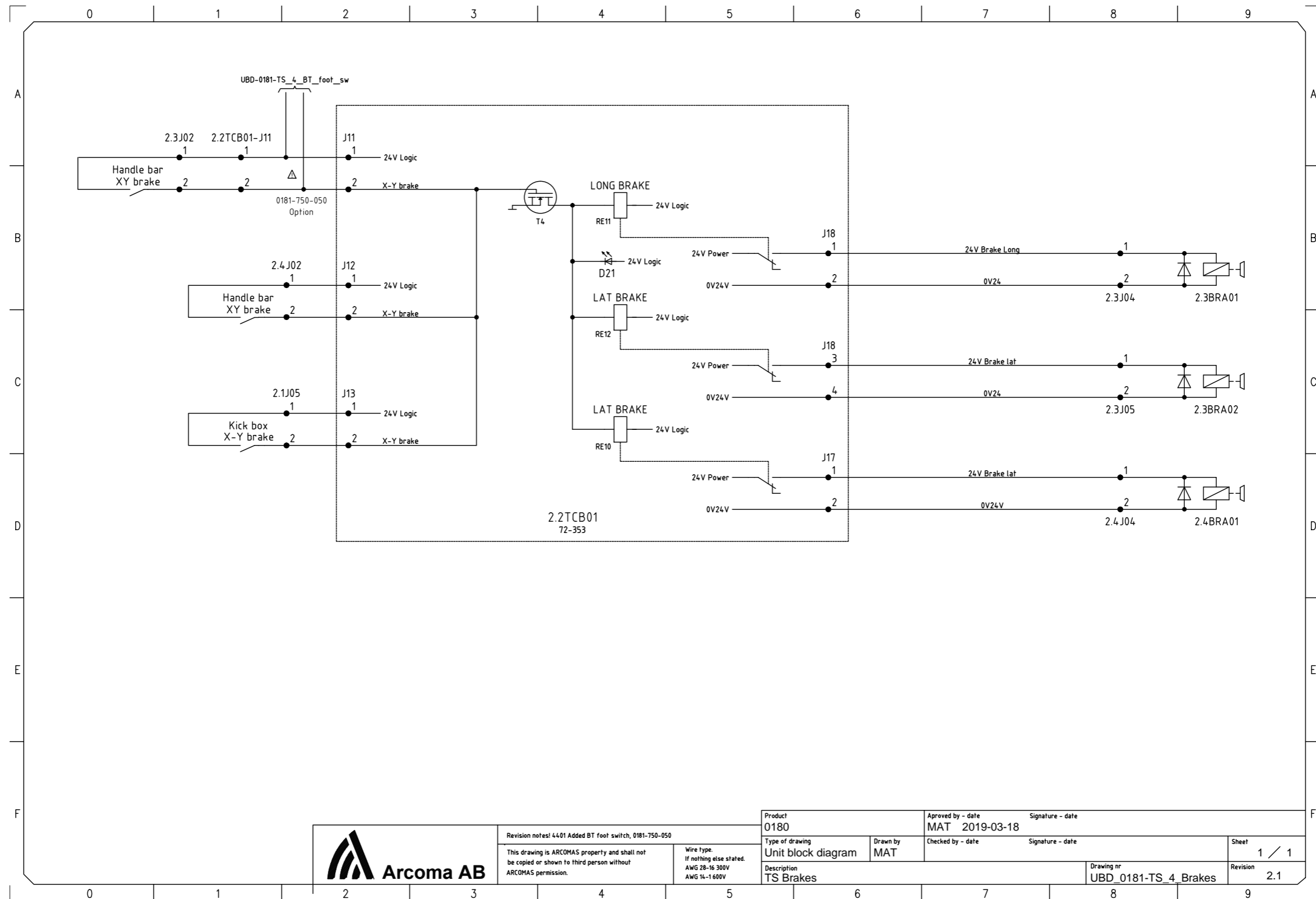

Revision notes! 4.401 Added BT foot switch, 0181-750-050  
 This drawing is ARCOMAS property and shall not be copied or shown to third person without ARCOMAS permission.  
 Wire type:  
 If nothing else stated:  
 AWG 28-16 300V  
 AWG 14-1 600V

Product 0180	Approved by - date MAT 2019-03-18	Signature - date
Type of drawing Unit block diagram	Drawn by MAT	Checked by - date Signature - date
Description TS Brakes	Drawing nr UBD_0181-TS_4_Brakes	Sheet 1 / 1
		Revision 2.1





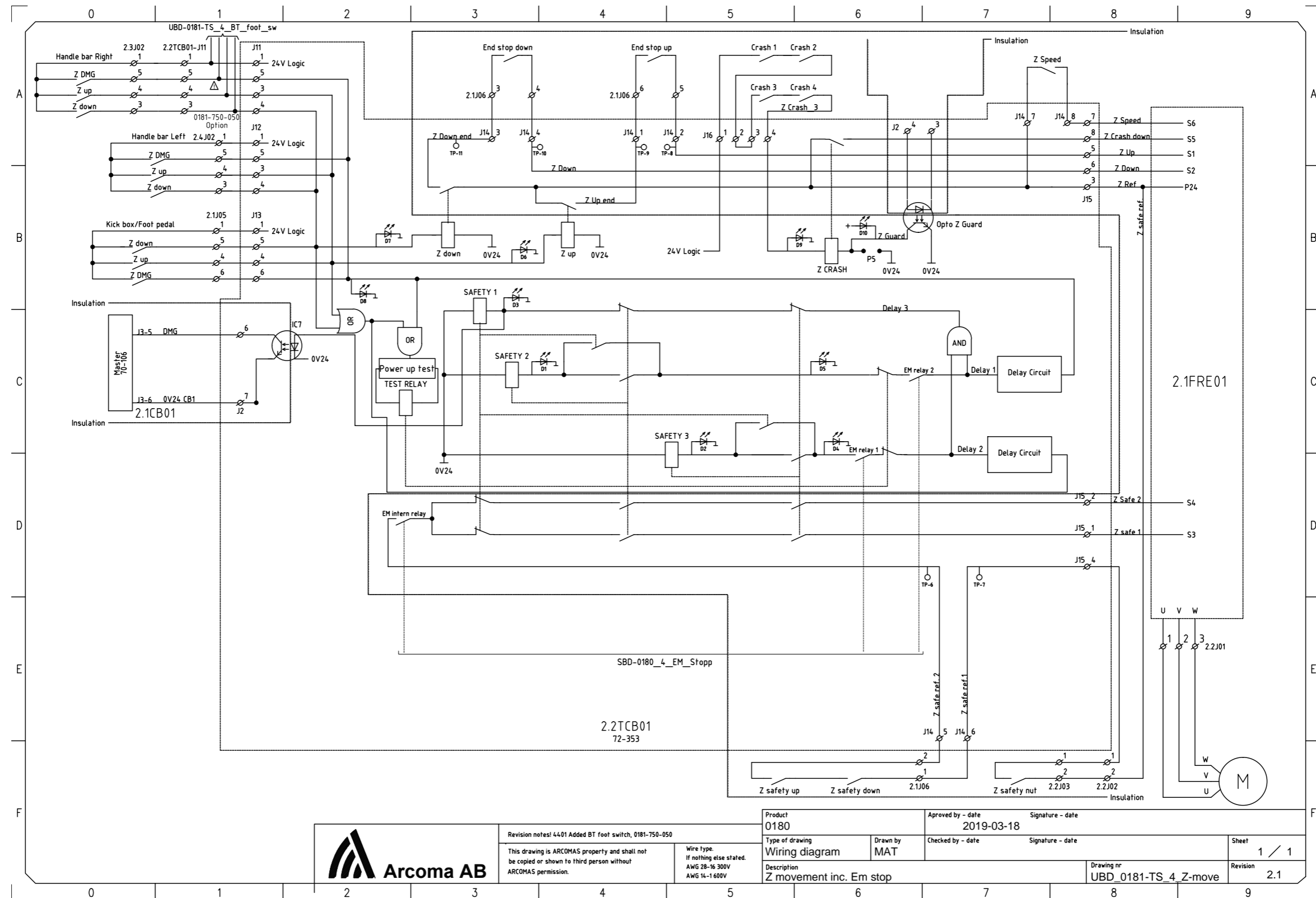

Revision notes! 4.01 Added BT foot switch, 0181-750-050  
 This drawing is ARCOMAS property and shall not be copied or shown to third person without ARCOMAS permission.  
 Wire type:  
 If nothing else stated:  
 AWG 28-16 300V  
 AWG 14-1 600V

Product <b>0180</b>		Approved by - date <b>2019-03-18</b>		Signature - date	
Type of drawing <b>Wiring diagram</b>	Drawn by <b>MAT</b>	Checked by - date	Signature - date		
Description <b>Z movement inc. Em stop</b>				Drawing nr <b>UBD_0181-TS_4_Z-move</b>	
				Sheet <b>1 / 1</b>	
				Revision <b>2.1</b>	



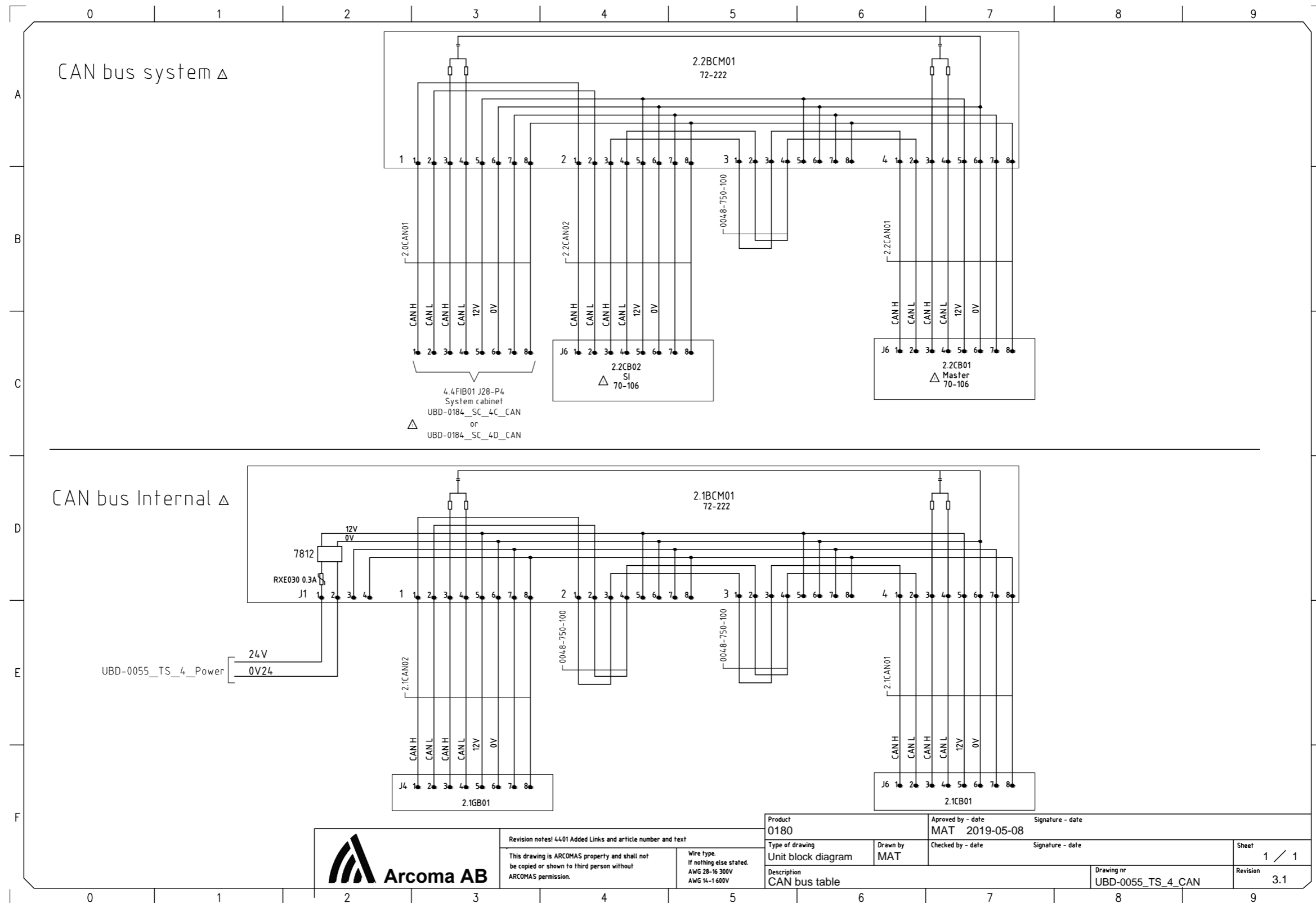

Revision notes! 4.01 Added Links and article number and text  
 This drawing is ARCOMAS property and shall not be copied or shown to third person without ARCOMAS permission.  
 Wire type. If nothing else stated. AWG 28-16 300V AWG 14-1 600V

Product 0180	Approved by - date MAT 2019-05-08	Signature - date
Type of drawing Unit block diagram	Drawn by MAT	Checked by - date
Description CAN bus table	Signature - date	Sheet 1 / 1
	Drawing nr UBD-0055_TS_4_CAN	Revision 3.1



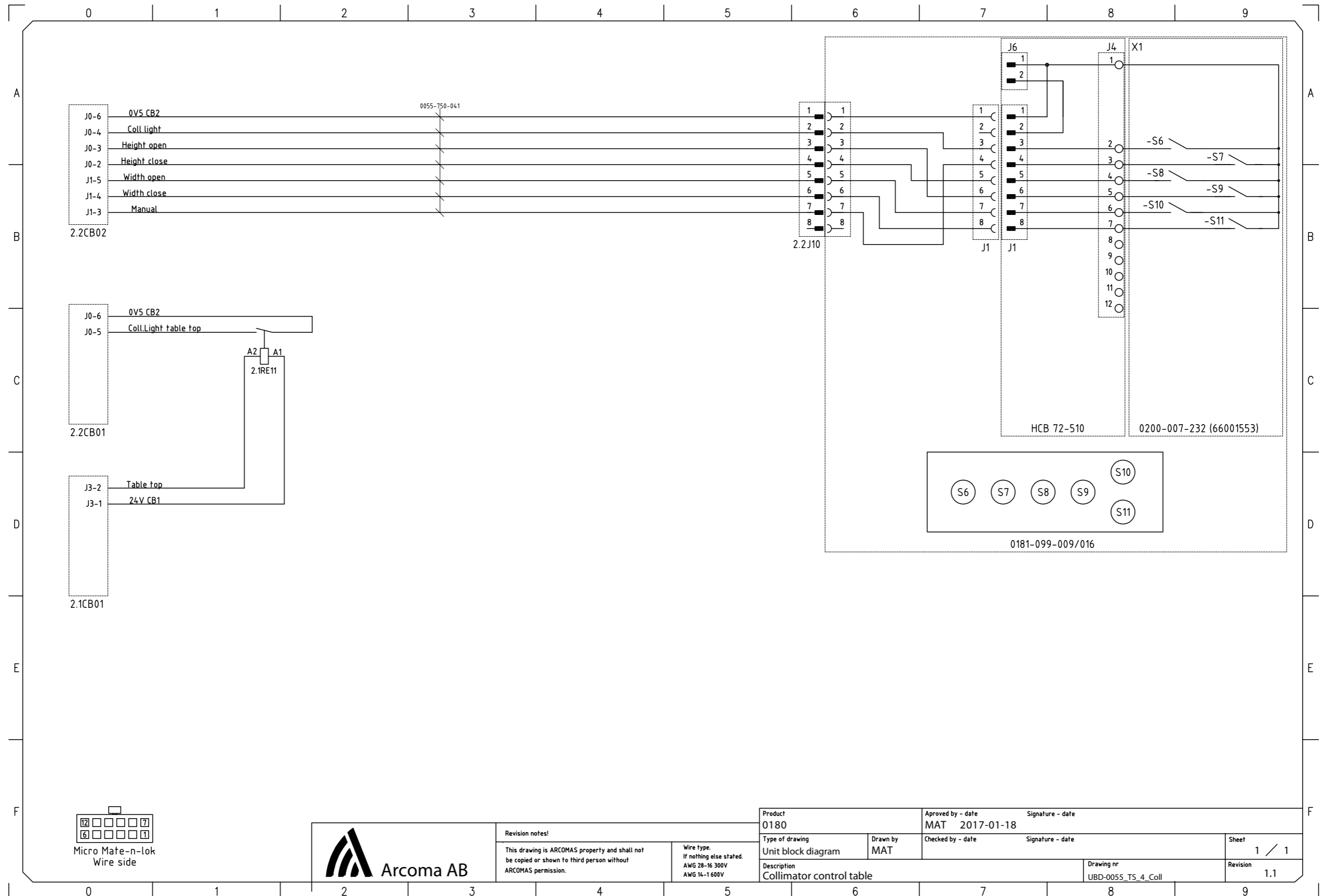

Micro Mate-n-lok  
Wire side



Revision notes!  
This drawing is ARCOMAS property and shall not be copied or shown to third person without ARCOMAS permission.

Wire type.  
If nothing else stated.  
AWG 28-16 300V  
AWG 14-1 600V

Product 0180		Approved by - date MAT 2017-01-18		Signature - date	
Type of drawing Unit block diagram	Drawn by MAT		Checked by - date		Signature - date
Description Collimator control table			Drawing nr UBD-0055_TS_4_Coll		Sheet 1 / 1
					Revision 1.1



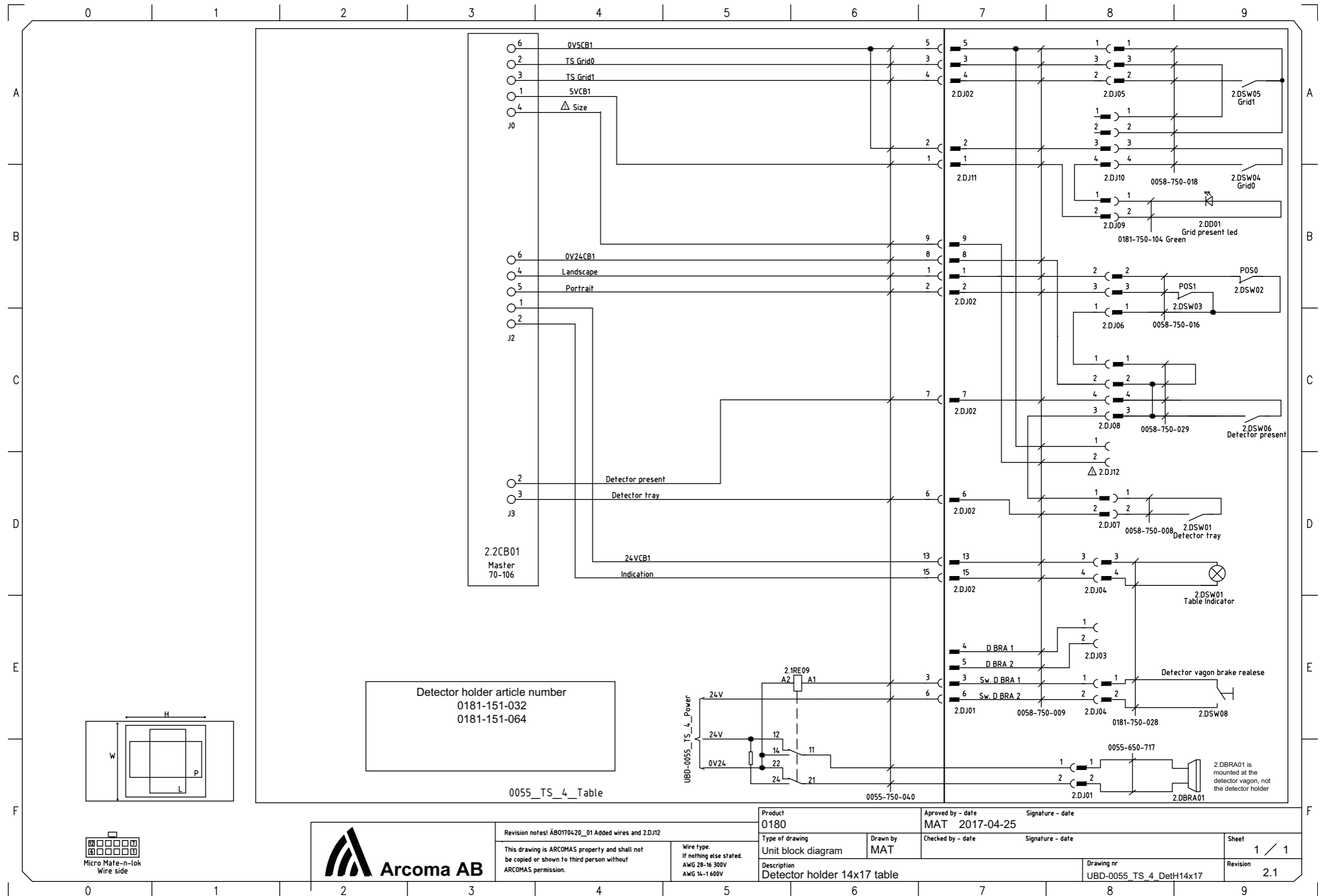





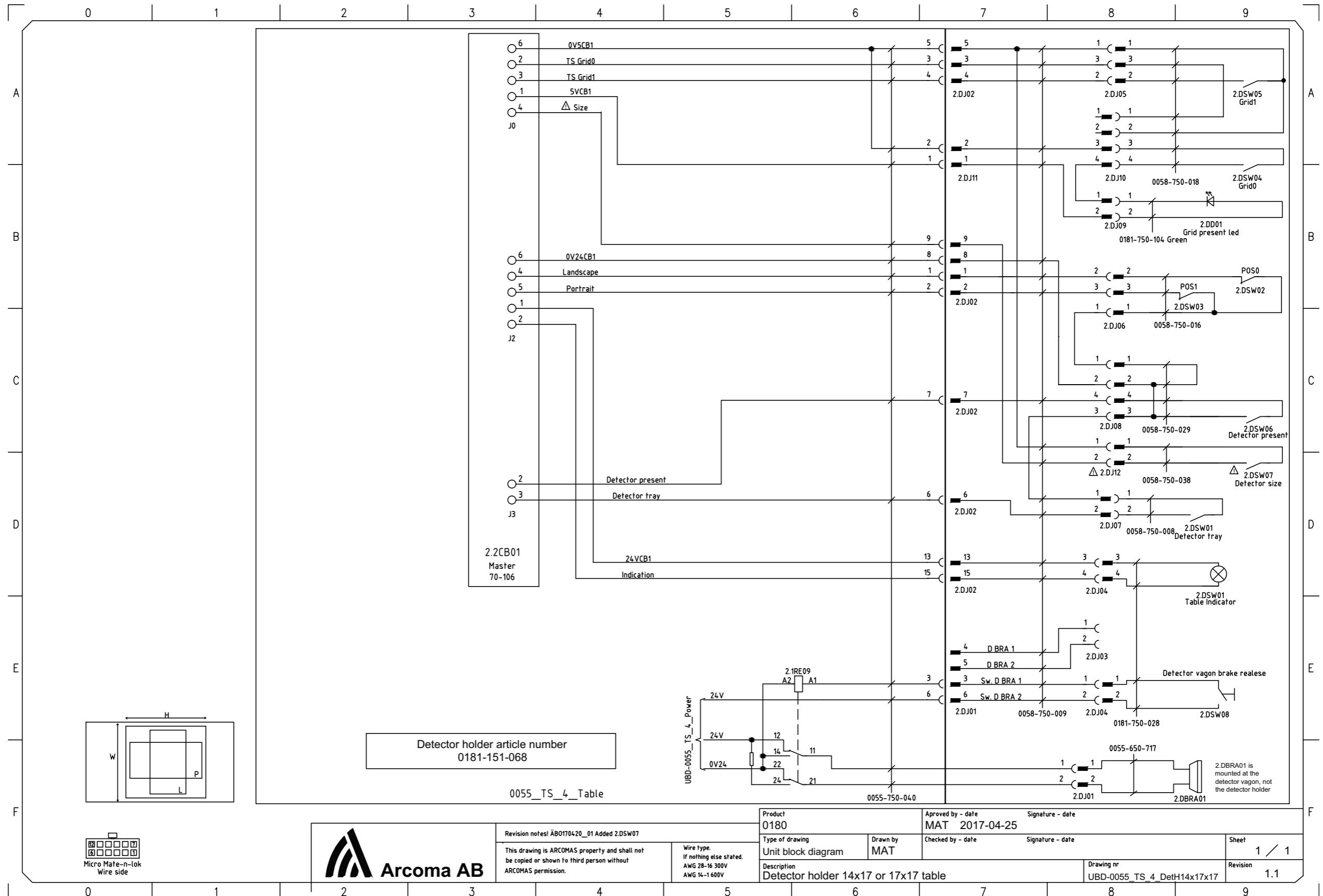



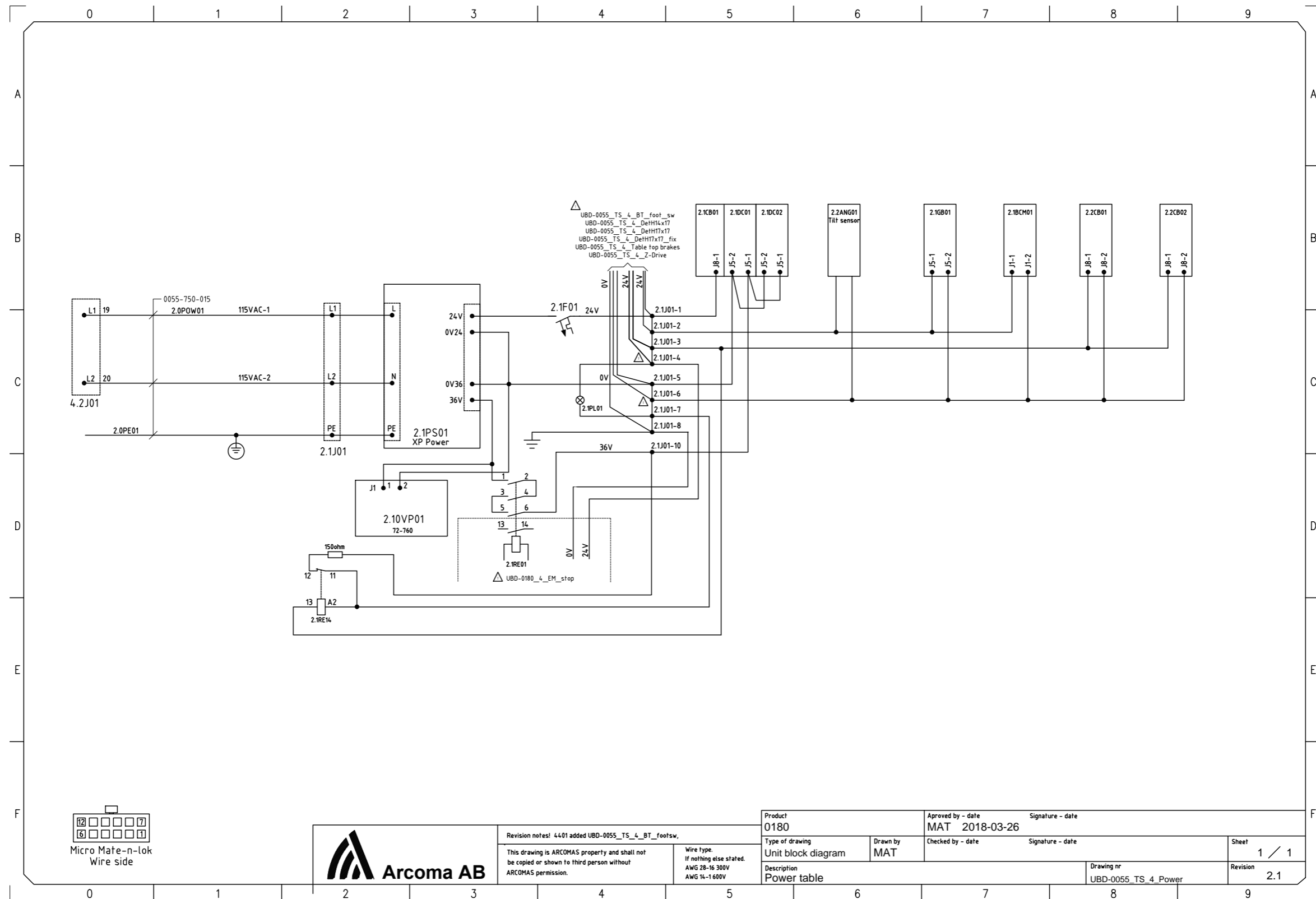



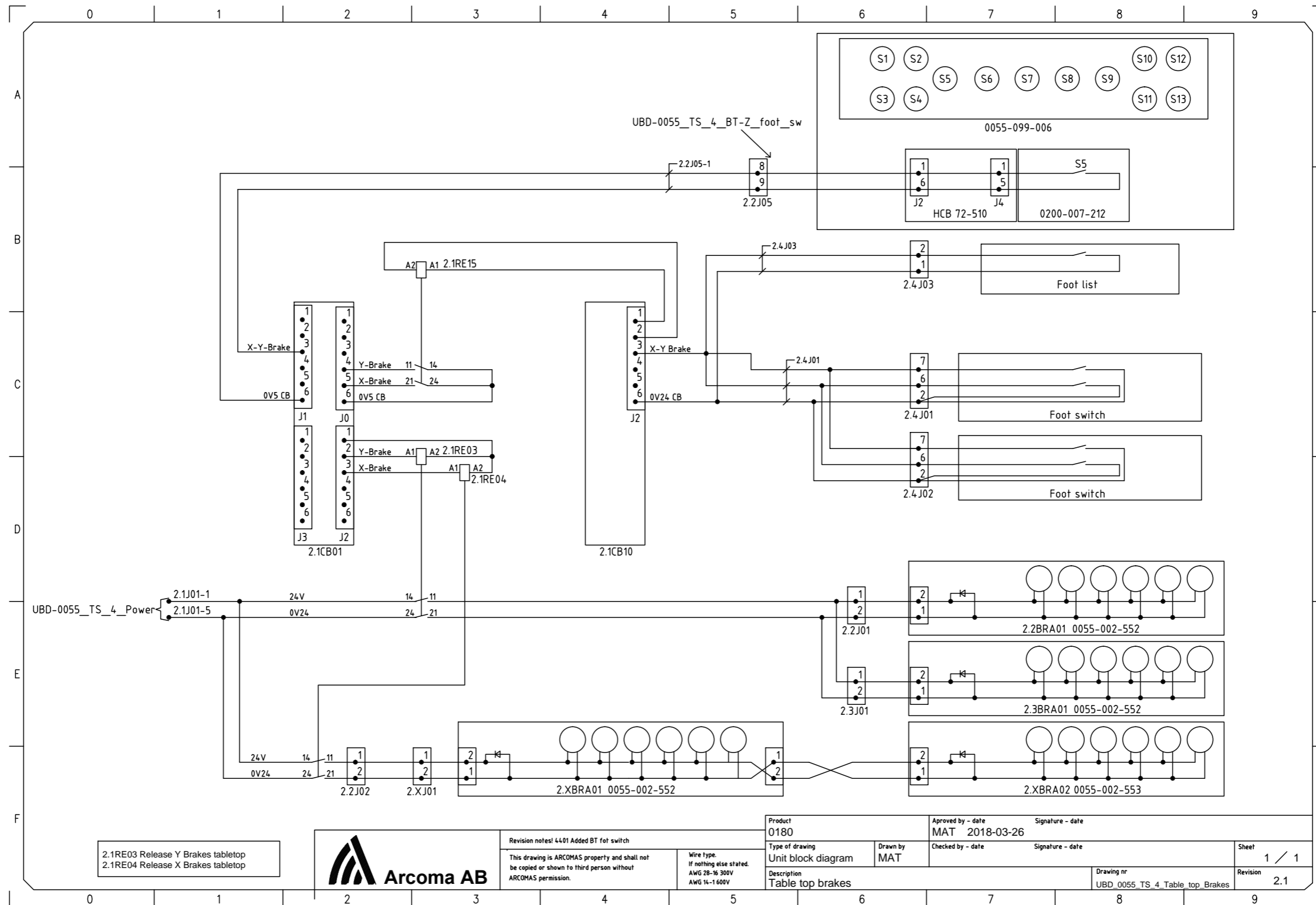



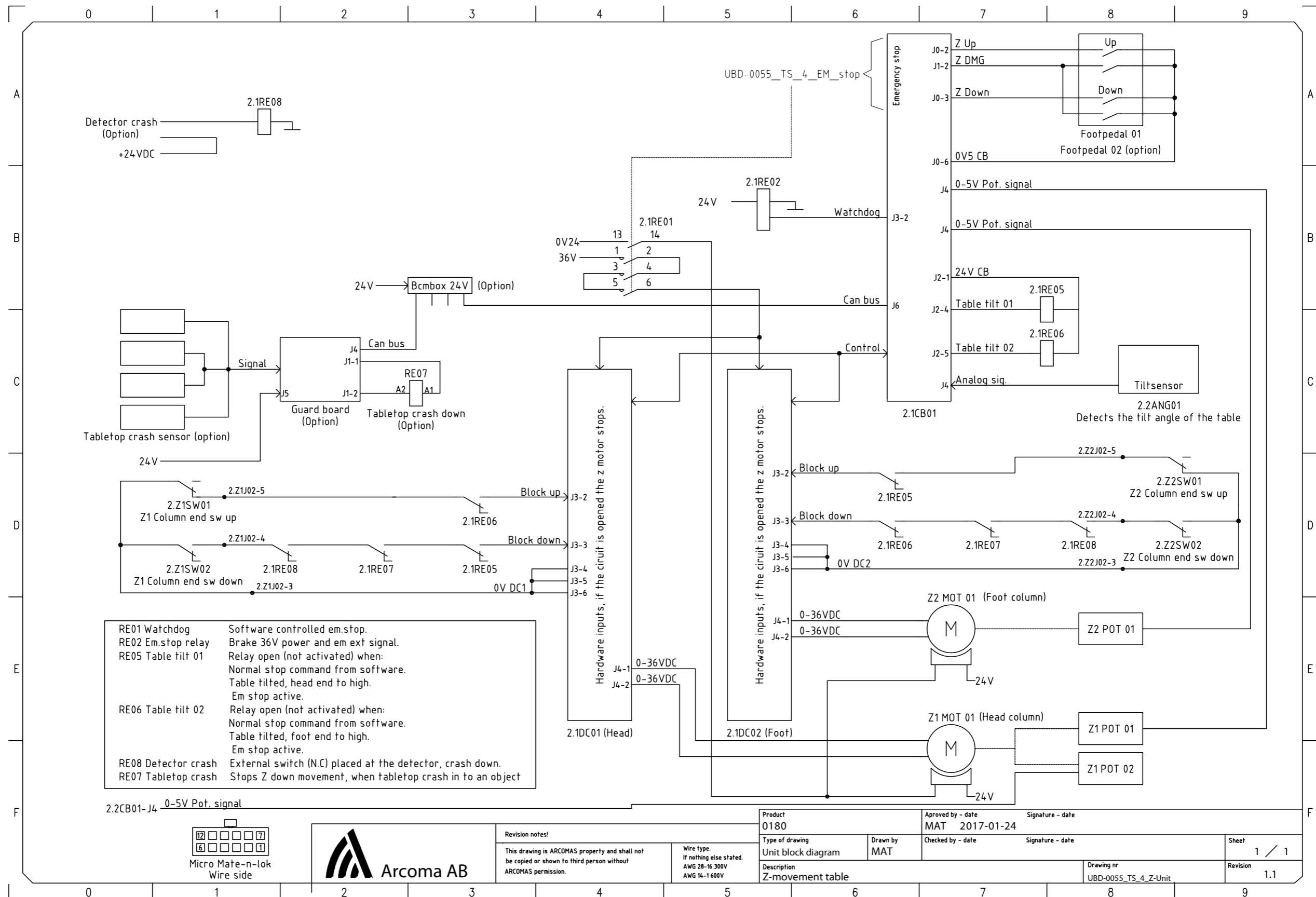





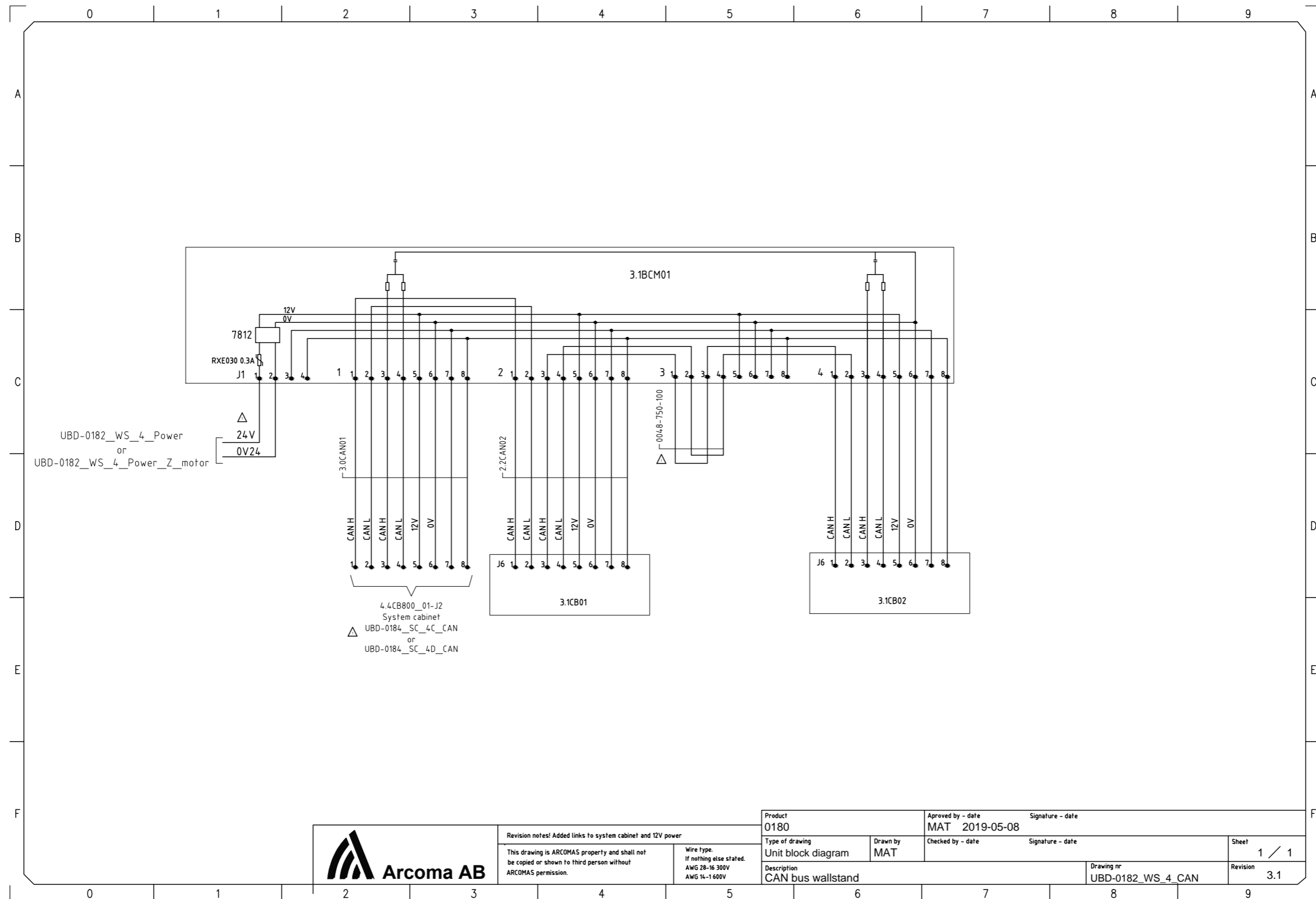

Revision notes! Added links to system cabinet and 12V power  
 This drawing is ARCOMAS property and shall not be copied or shown to third person without ARCOMAS permission.  
 Wire type:  
 If nothing else stated:  
 AWG 28-16 300V  
 AWG 14-1 600V

Product 0180	Approved by - date MAT 2019-05-08	Signature - date
Type of drawing Unit block diagram	Checked by - date	Signature - date
Drawn by MAT		
Description CAN bus wallstand	Drawing nr UBD-0182_WS_4_CAN	Sheet 1 / 1
		Revision 3.1



# Electrical drawings

## Unit block diagram (4C valid for Omnera 400T)

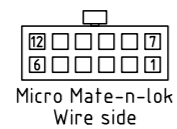
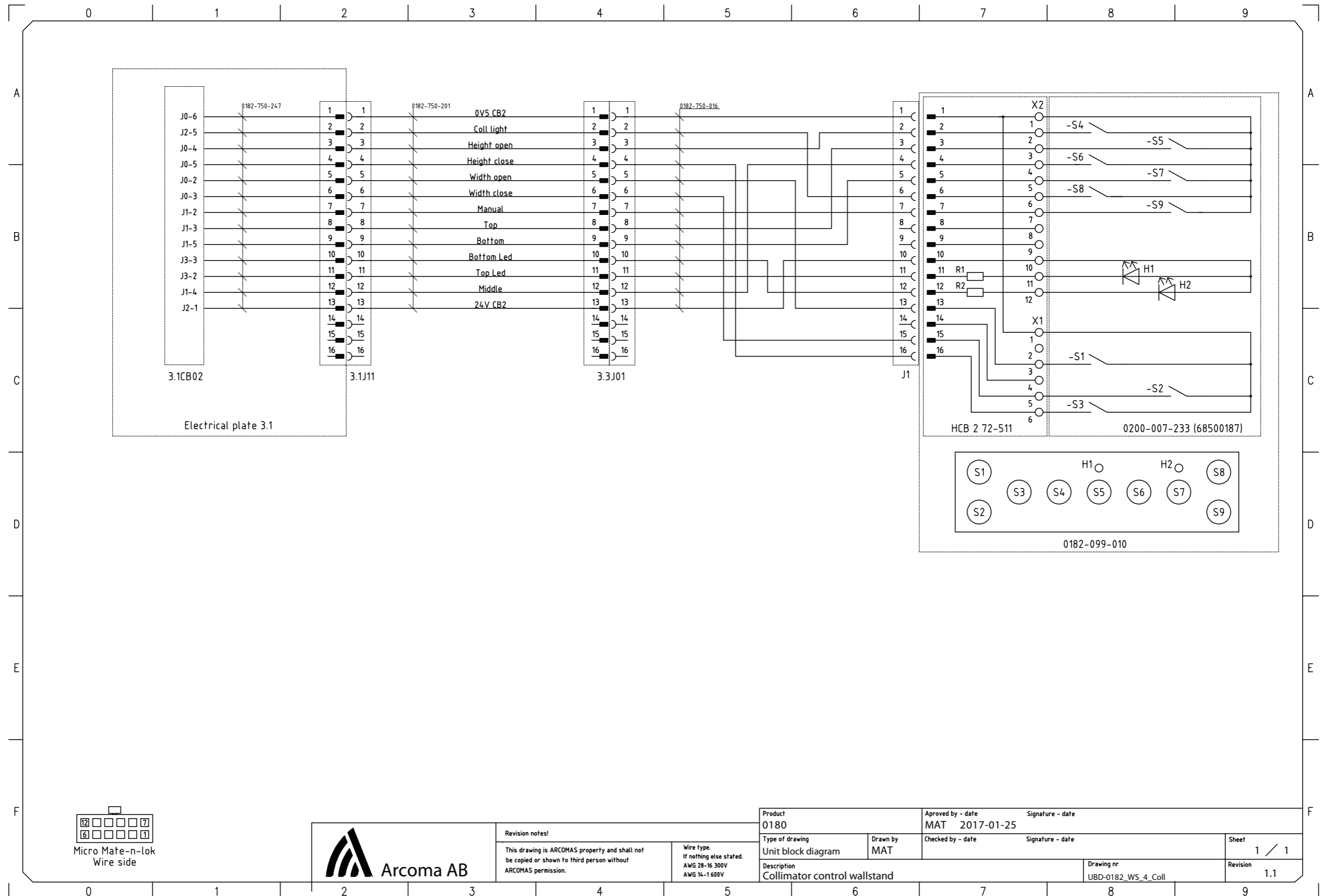

Revision notes!  
This drawing is ARCOMAS property and shall not be copied or shown to third person without ARCOMAS permission.

Wire type.  
If nothing else stated.  
AWG 28-16 300V  
AWG 14-1 600V

Product 0180		Approved by - date MAT 2017-01-25		Signature - date	
Type of drawing Unit block diagram	Drawn by MAT		Checked by - date		Signature - date
Description Collimator control wallstand			Drawing nr UBD-0182_WS_4_Coll		Sheet 1 / 1
					Revision 1.1



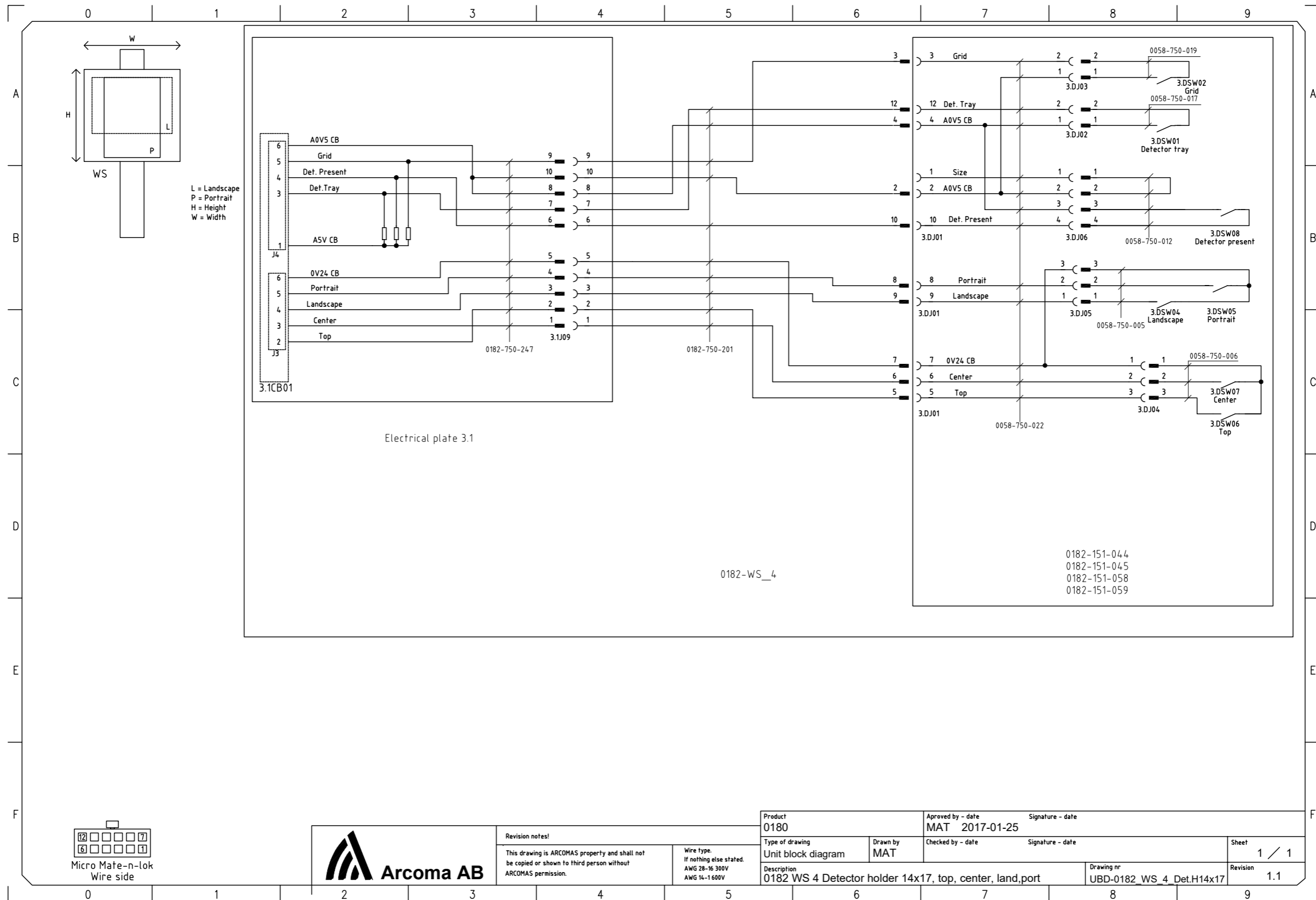



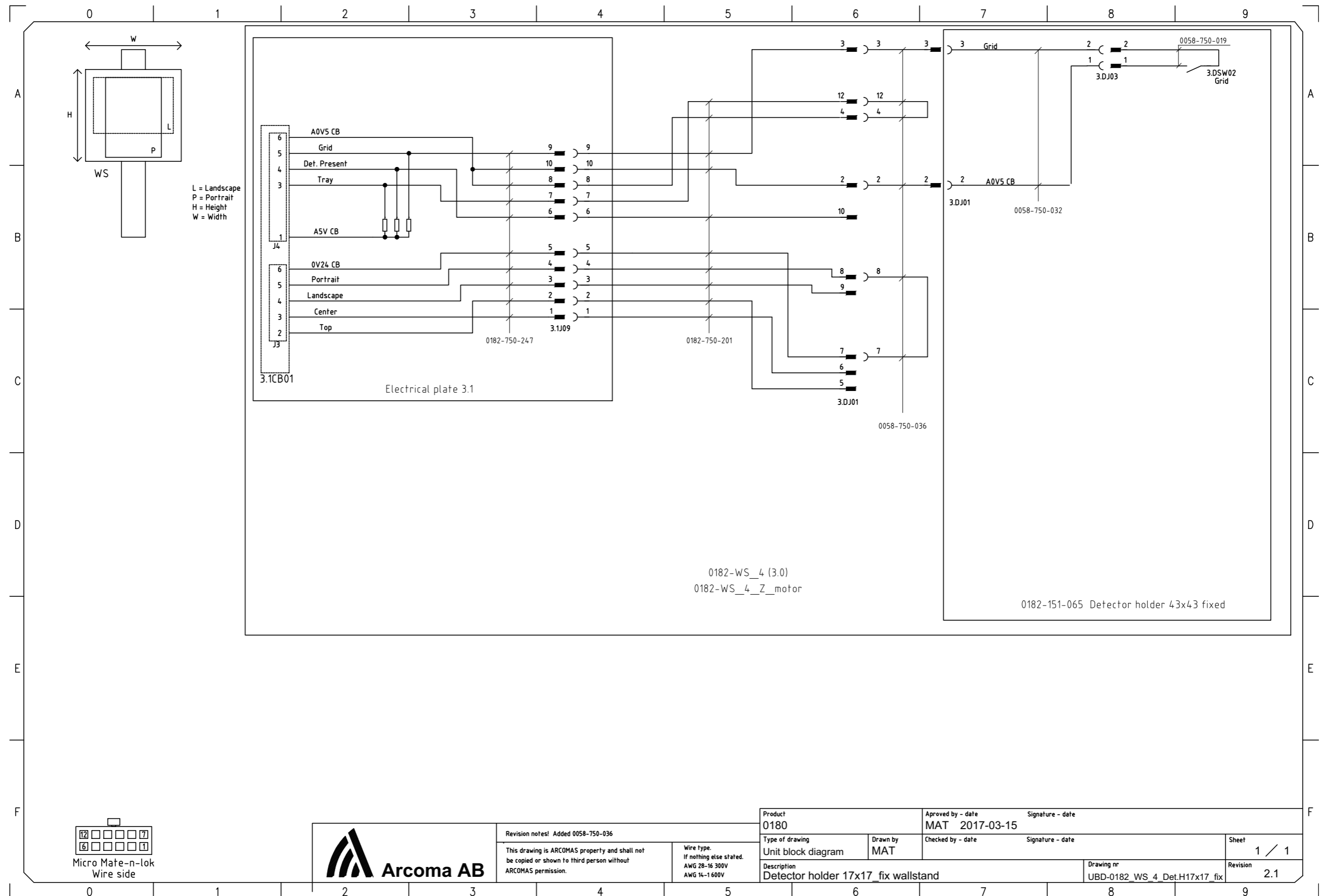





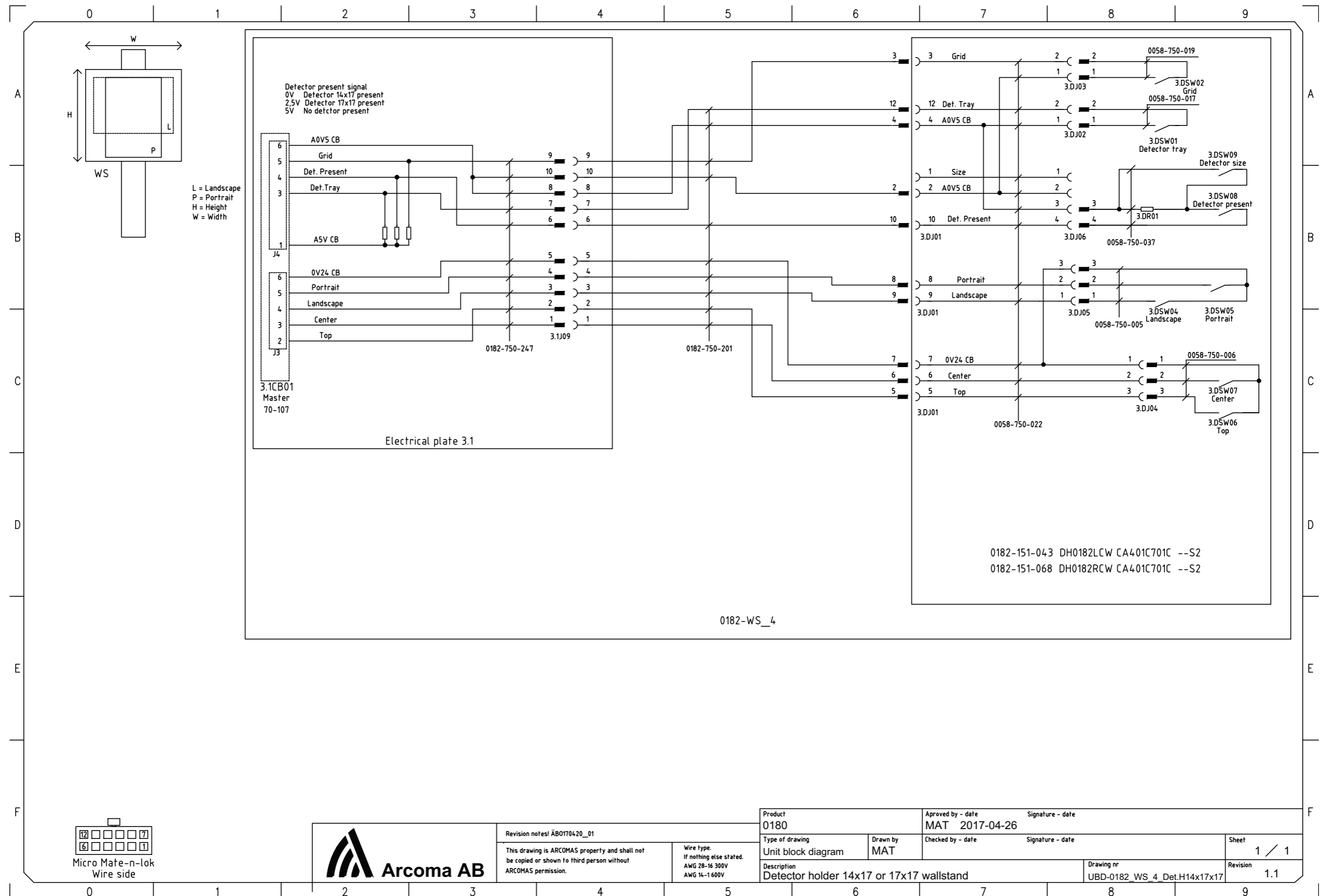



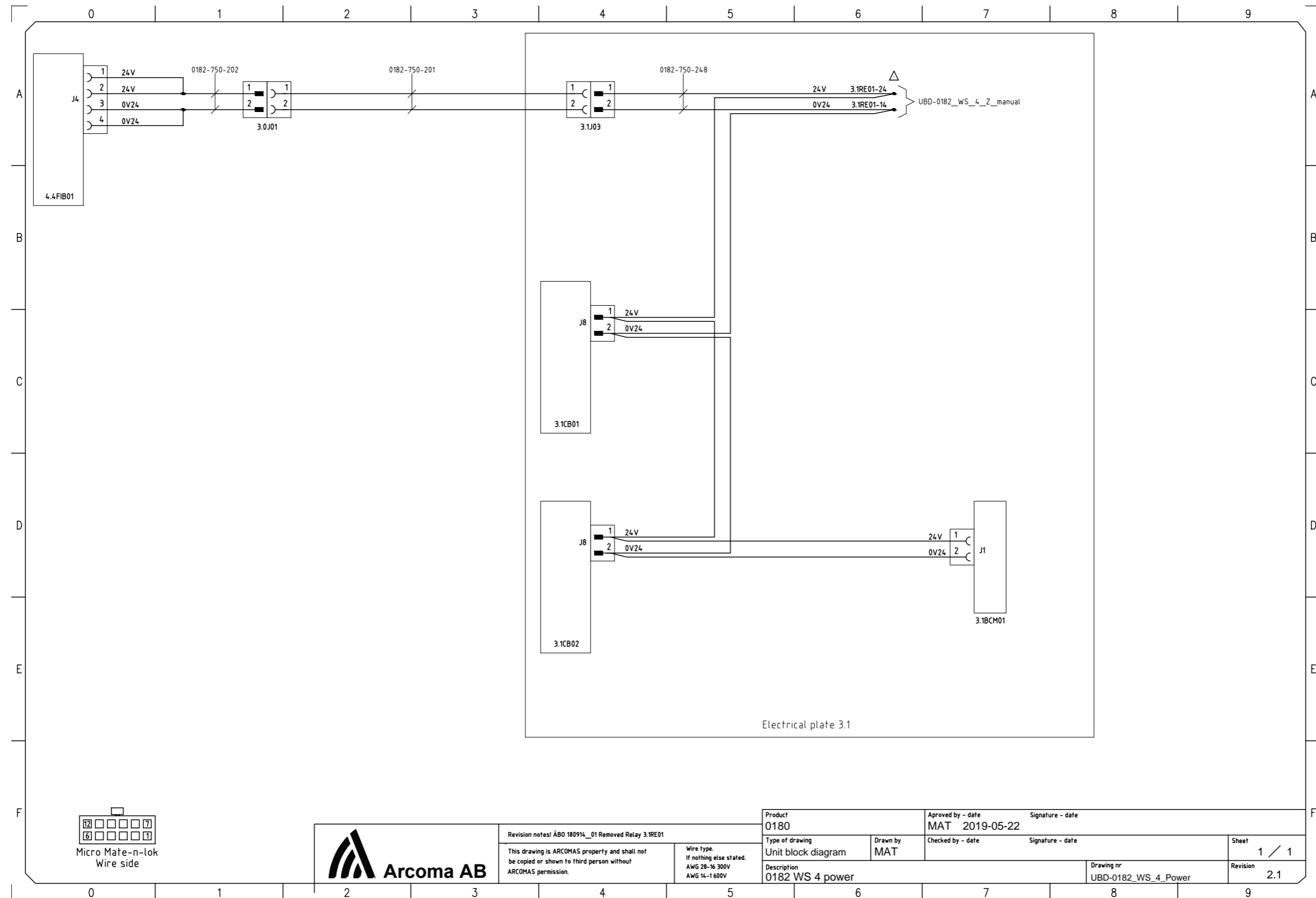

Micro Mate-n-lok  
Wire side



Revision notes! ÅBD 180914\_01 Removed Relay 3.1RE01  
This drawing is ARCOMAS property and shall not be copied or shown to third person without ARCOMAS permission.  
Wire type:  
If nothing else stated:  
AWG 28-16 300V  
AWG 14-1 600V

Product 0180	Approved by - date MAT 2019-05-22	Signature - date
Type of drawing Unit block diagram	Drawn by MAT	Checked by - date
Description 0182 WS 4 power		Drawing nr UBD-0182_WS_4_Power
		Sheet 1 / 1
		Revision 2.1



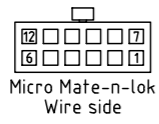
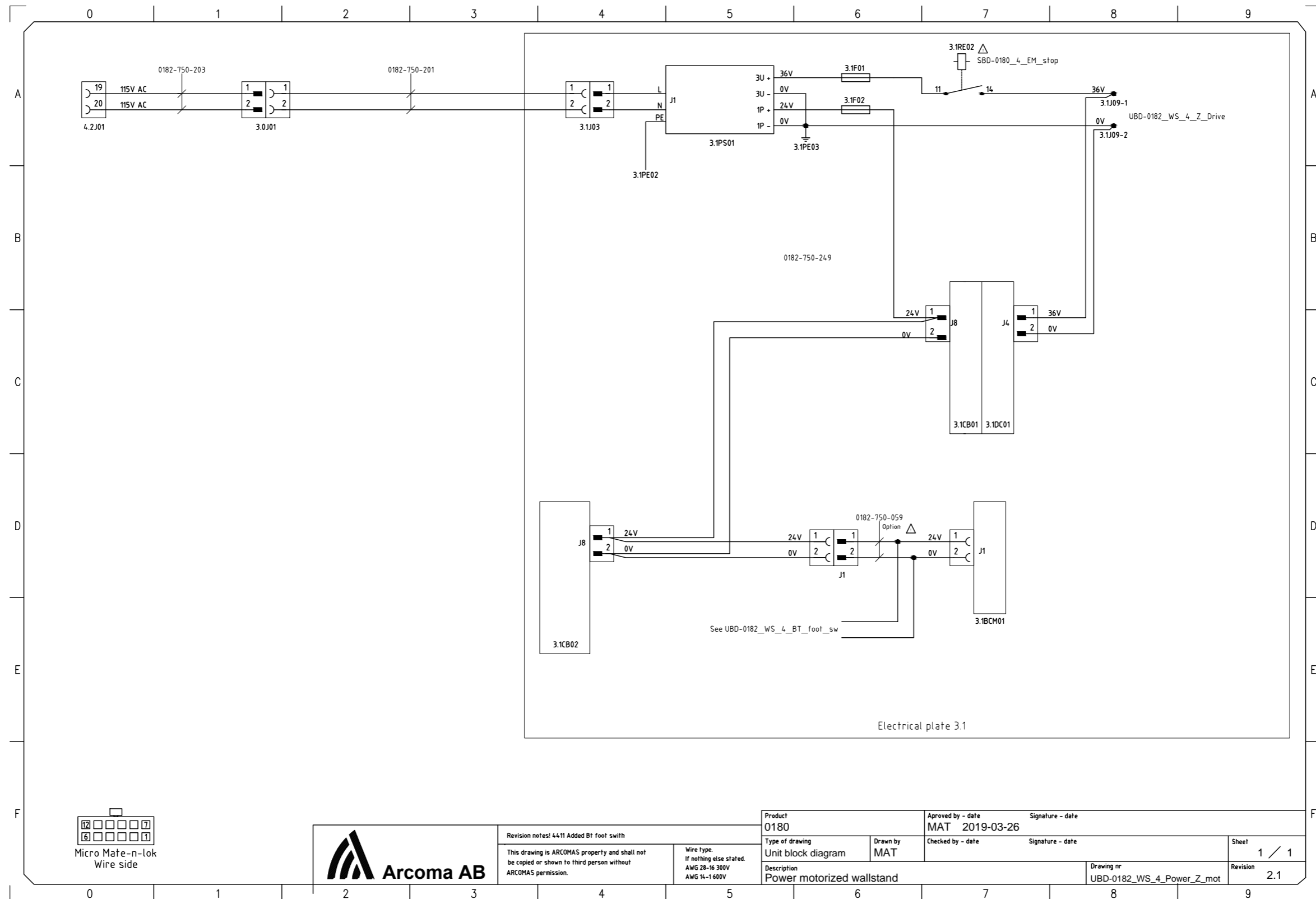

Revision notes! 4.11 Added BT foot swith  
 This drawing is ARCOMAS property and shall not be copied or shown to third person without ARCOMAS permission.  
 Wire type:  
 If nothing else stated:  
 AWG 28-16 300V  
 AWG 14-1 600V

Product 0180	Approved by - date MAT 2019-03-26	Signature - date
Type of drawing Unit block diagram	Drawn by MAT	Checked by - date
Description Power motorized wallstand		Signature - date
Drawing nr UBD-0182_WS_4_Power_Z_mot		Sheet 1 / 1
Revision 2.1		



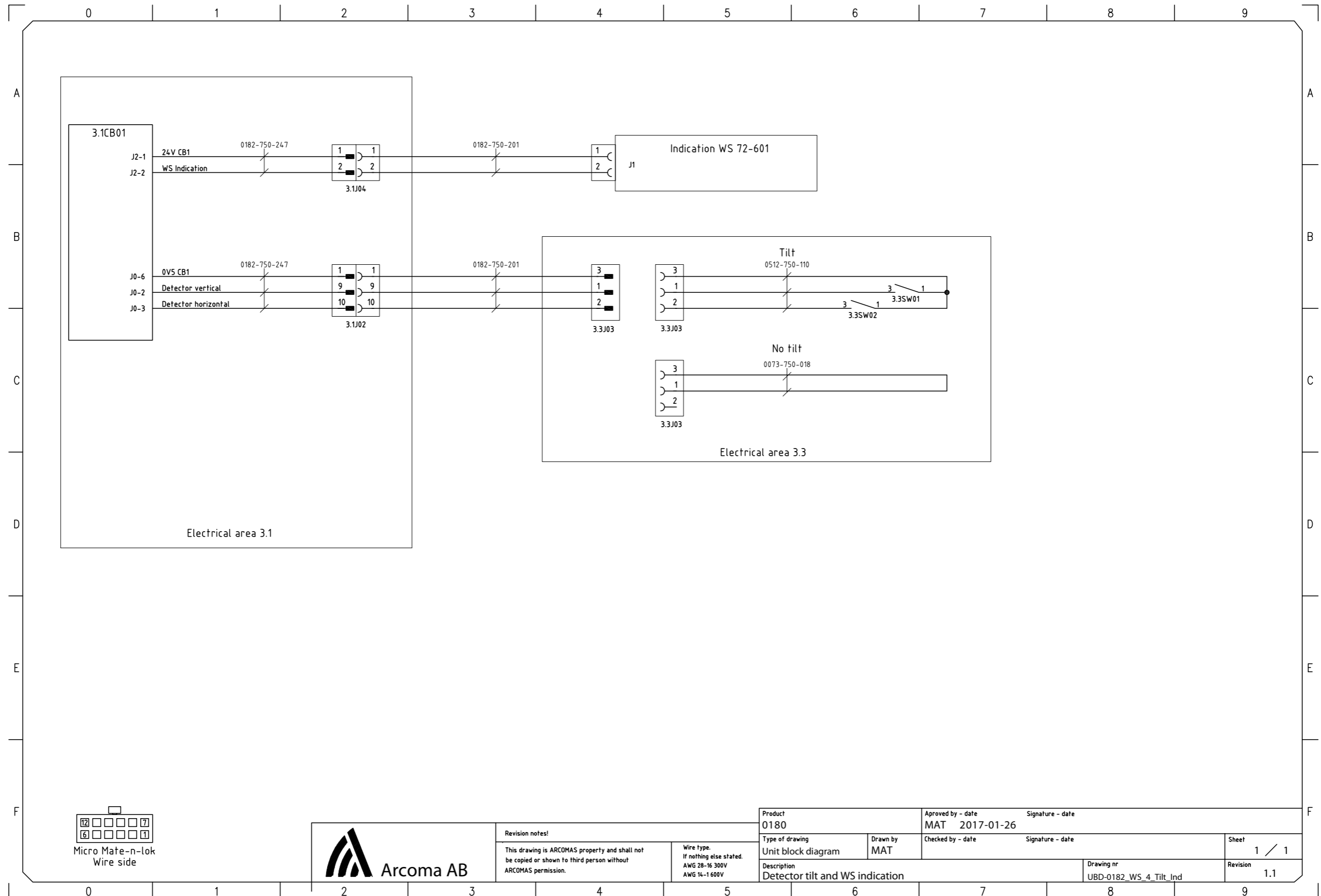





# Electrical drawings

## Unit block diagram (4C valid for Omnera 400T)

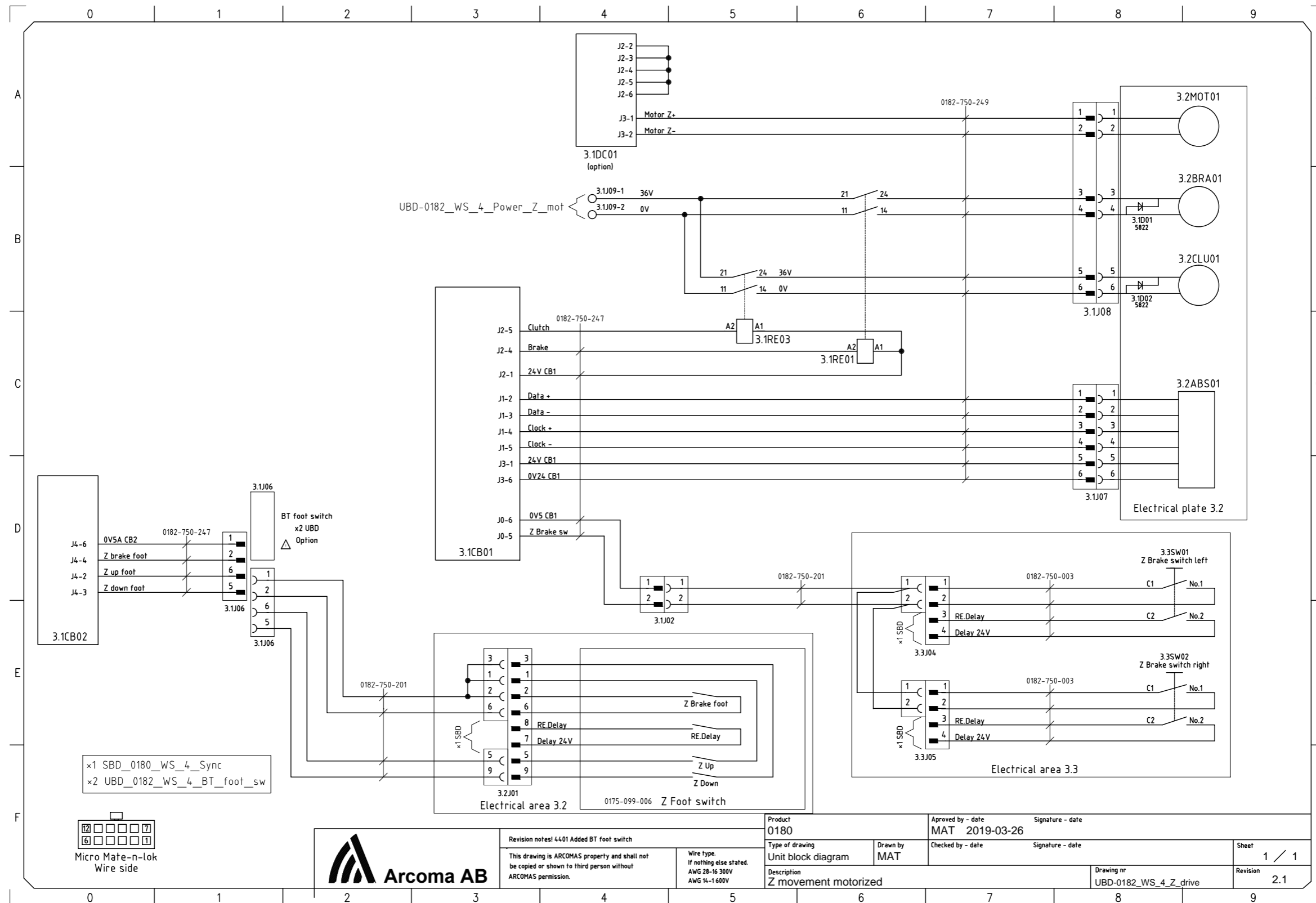

x1 SBD\_0180\_WS\_4\_Sync  
x2 UBD\_0182\_WS\_4\_BT\_foot\_sw

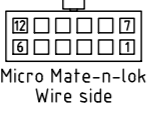

Revision notes! 4.01 Added BT foot switch  
This drawing is ARCOMAS property and shall not be copied or shown to third person without ARCOMAS permission.  
Wire type. If nothing else stated. AWG 28-16 300V AWG 14-1 600V

Product 0180	Approved by - date MAT 2019-03-26	Signature - date
Type of drawing Unit block diagram	Checked by - date	Signature - date
Drawn by MAT		
Description Z movement motorized	Drawing nr UBD-0182_WS_4_Z_drive	Sheet 1 / 1
		Revision 2.1



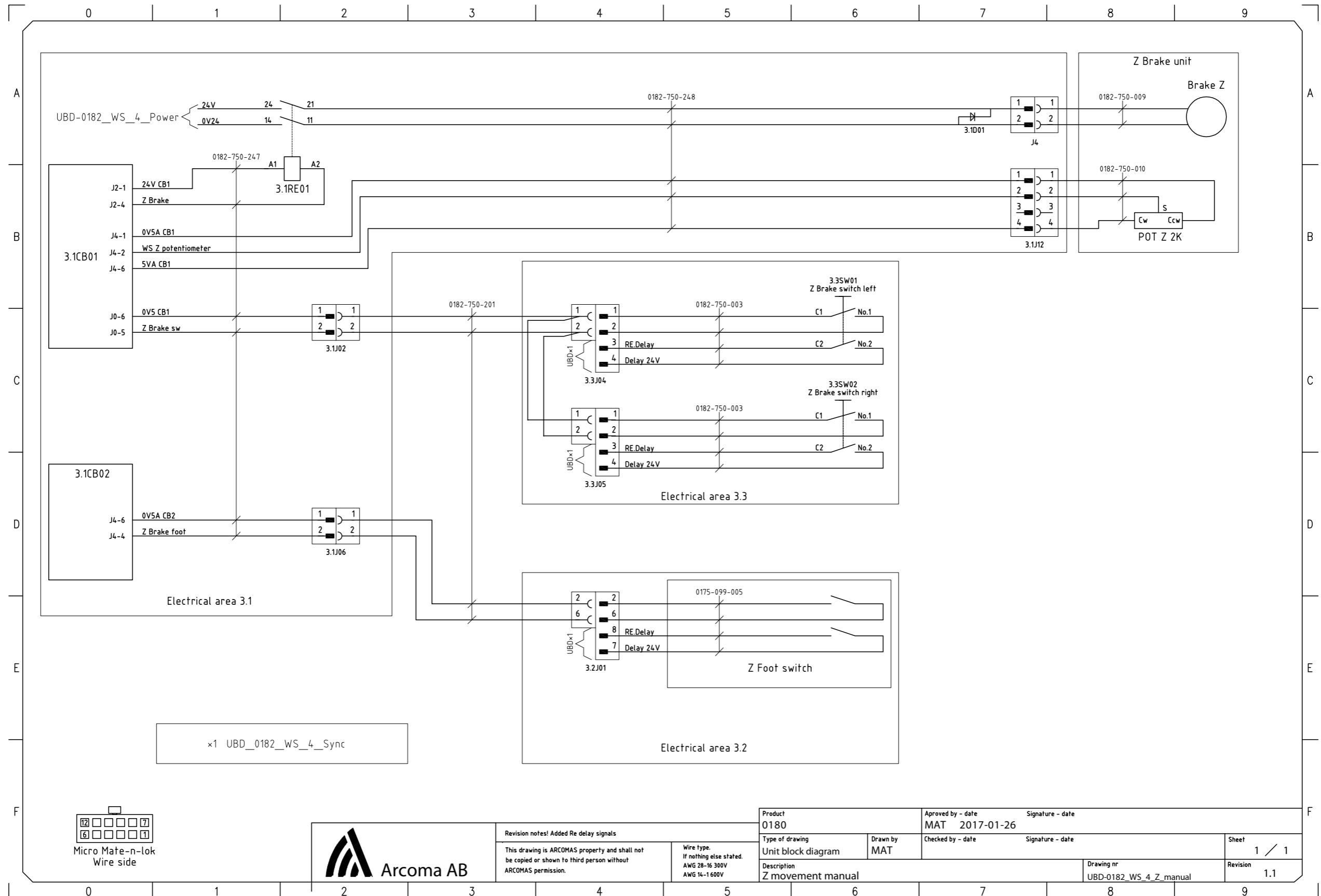



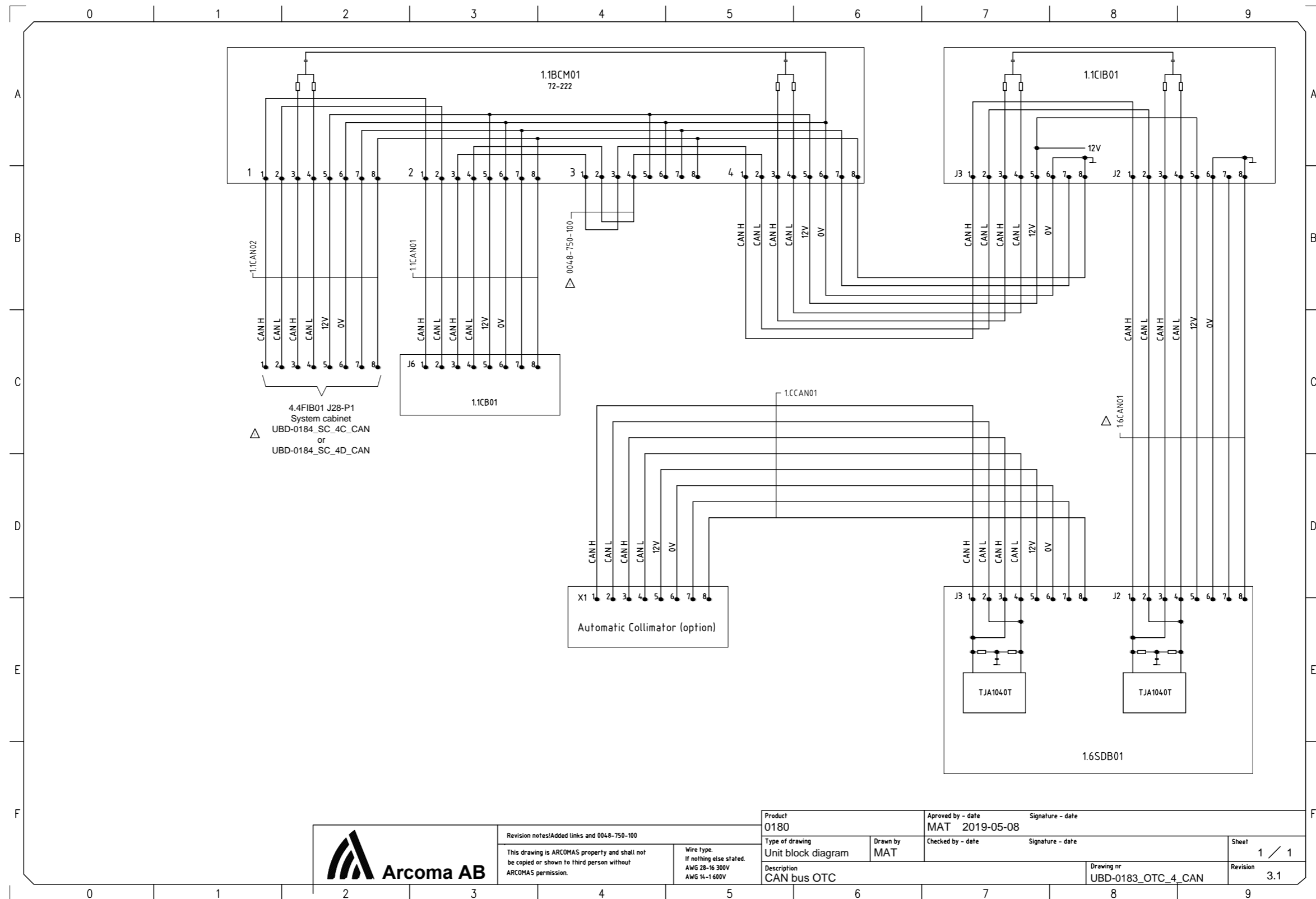

Revision notes: Added links and 004.8-750-100

This drawing is ARCOMAS property and shall not be copied or shown to third person without ARCOMAS permission.

Wire type:  
If nothing else stated:  
AWG 28-16 300V  
AWG 14-1 600V

Product <b>0180</b>	Approved by - date <b>MAT 2019-05-08</b>	Signature - date
Type of drawing Unit block diagram	Checked by - date	Signature - date
Drawn by <b>MAT</b>	Drawing nr <b>UBD-0183_OTC_4_CAN</b>	
Description <b>CAN bus OTC</b>	Sheet <b>1 / 1</b>	Revision <b>3.1</b>



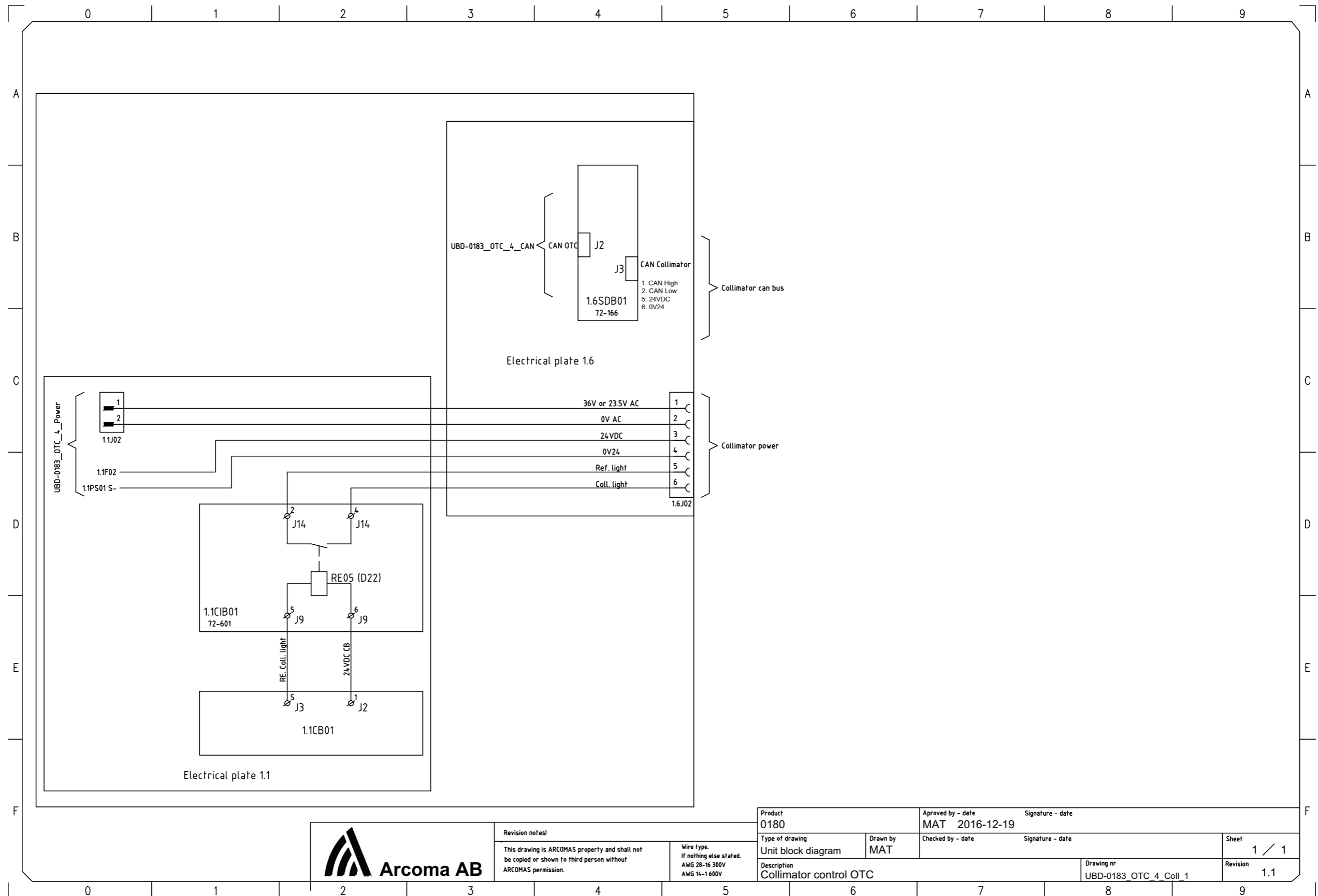

Revision notes:  
This drawing is ARCOMAS property and shall not be copied or shown to third person without ARCOMAS permission.

Wire type:  
If nothing else stated:  
AWG 28-16 300V  
AWG 14-1600V

Product 0180	Approved by - date MAT 2016-12-19	Signature - date
Type of drawing Unit block diagram	Drawn by MAT	Checked by - date Signature - date
Description Collimator control OTC	Drawing nr UBD-0183_OTC_4_Coll_1	Sheet 1 / 1
		Revision 1.1





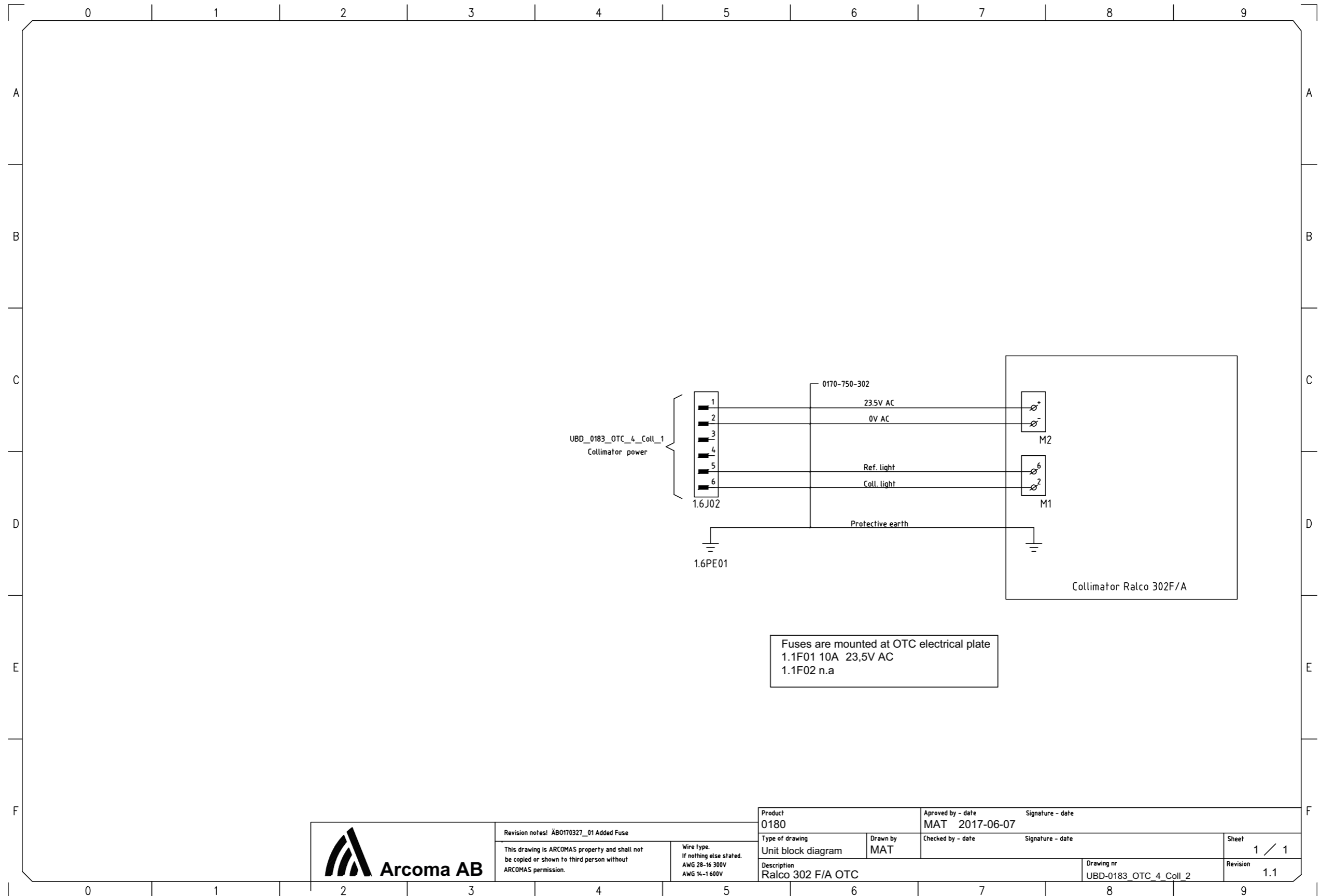

Revision notes! ÅB0170327\_01 Added Fuse  
This drawing is ARCOMAS property and shall not be copied or shown to third person without ARCOMAS permission.

Wire type.  
If nothing else stated.  
AWG 28-16 300V  
AWG 14-1600V

Product 0180		Approved by - date MAT 2017-06-07		Signature - date	
Type of drawing Unit block diagram	Drawn by MAT	Checked by - date		Signature - date	
Description Ralco 302 F/A OTC				Drawing nr UBD-0183_OTC_4_Coll_2	Sheet 1 / 1
				Revision 1.1	



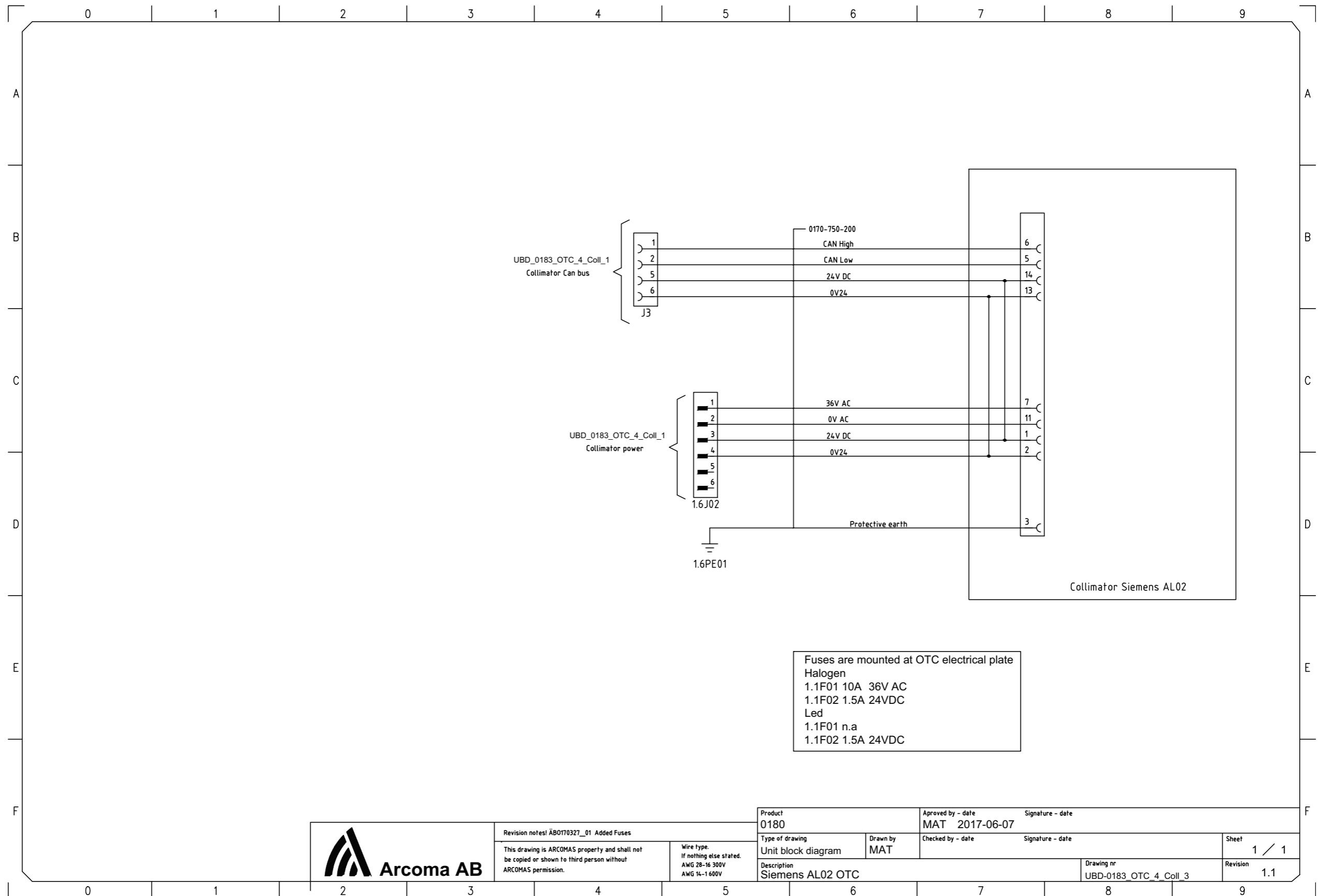



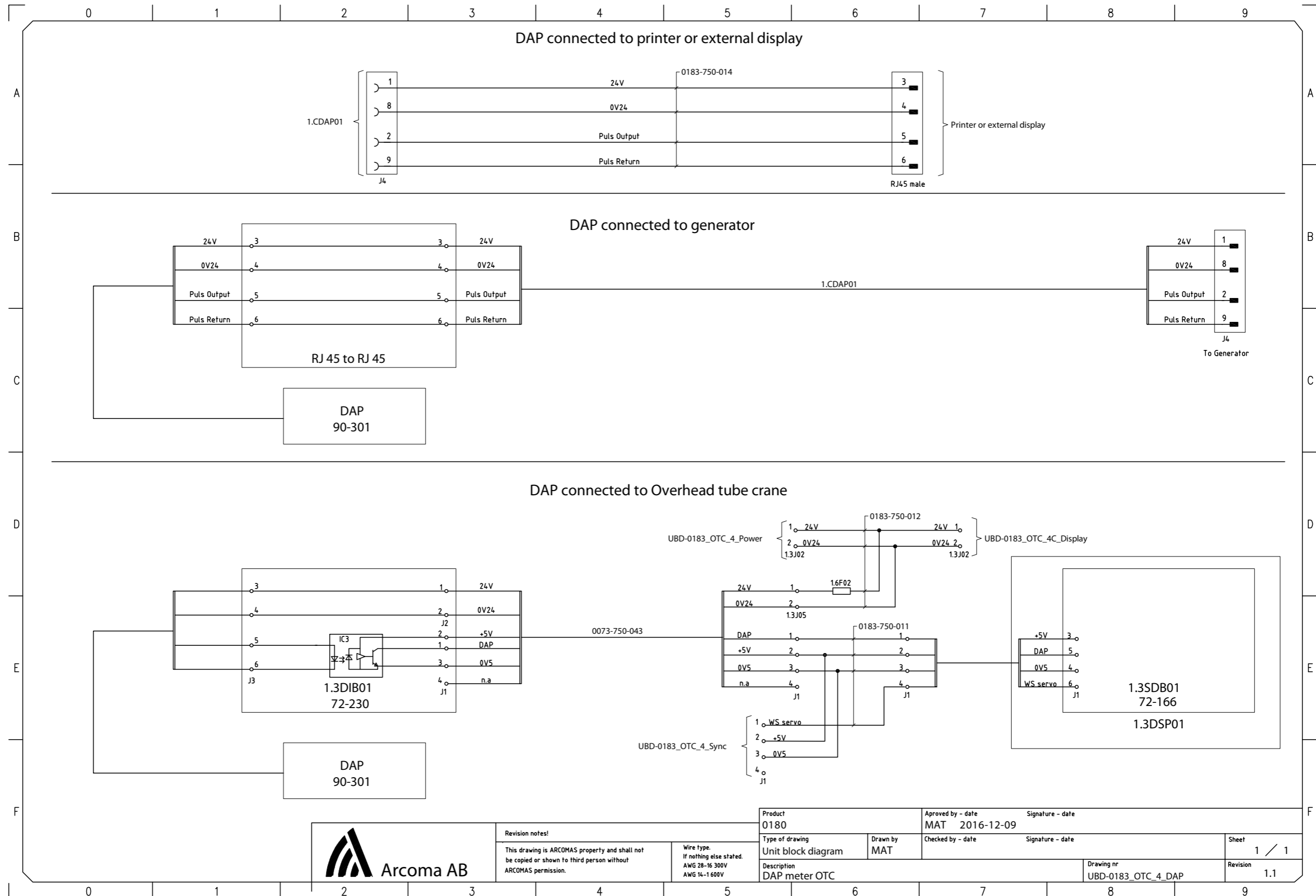

**Revision notes!**  
This drawing is ARCOMAS property and shall not be copied or shown to third person without ARCOMAS permission.

**Wire type.**  
If nothing else stated.  
AWG 28-16 300V  
AWG 14-1 600V

Product 0180	Approved by - date MAT 2016-12-09	Signature - date
Type of drawing Unit block diagram	Drawn by MAT	Checked by - date
Description DAP meter OTC	Drawing nr UBD-0183_OTC_4_DAP	Sheet 1 / 1
		Revision 1.1



# Electrical drawings

## Unit block diagram (4C valid for Omnera 400T)

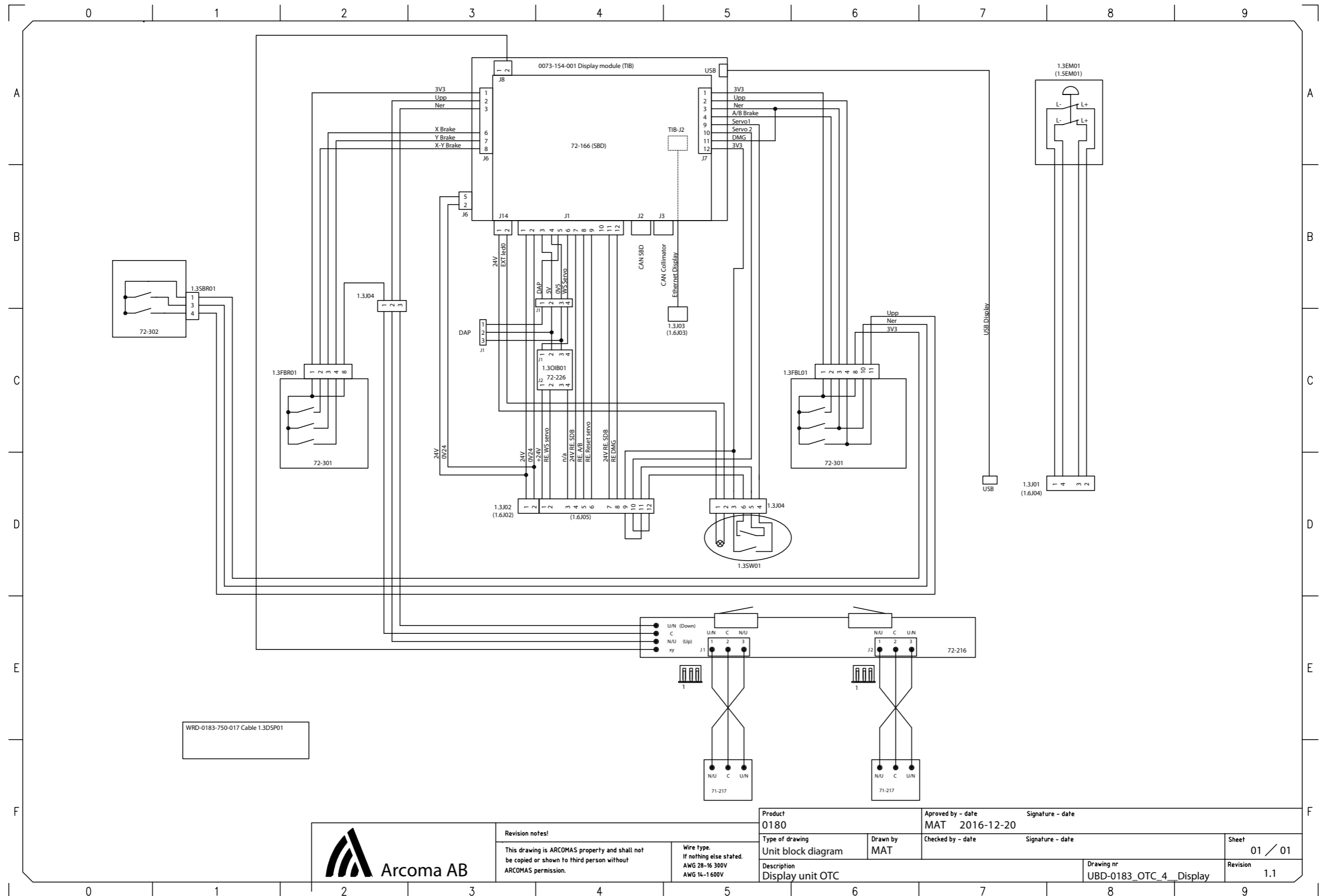

**Revision notes:**  
 This drawing is ARCOMAS property and shall not be copied or shown to third person without ARCOMAS permission.

**Wire type:**  
 If nothing else stated.  
 AWG 28-16 300V  
 AWG 14-1600V

Product <b>0180</b>		Approved by - date <b>MAT 2016-12-20</b>		Signature - date	
Type of drawing <b>Unit block diagram</b>		Drawn by <b>MAT</b>		Checked by - date	
Description <b>Display unit OTC</b>				Drawing nr <b>UBD-0183_OTC_4_Display</b>	
				Sheet <b>01 / 01</b>	
				Revision <b>1.1</b>	





# Electrical drawings

## Unit block diagram (4C valid for Omnera 400T)

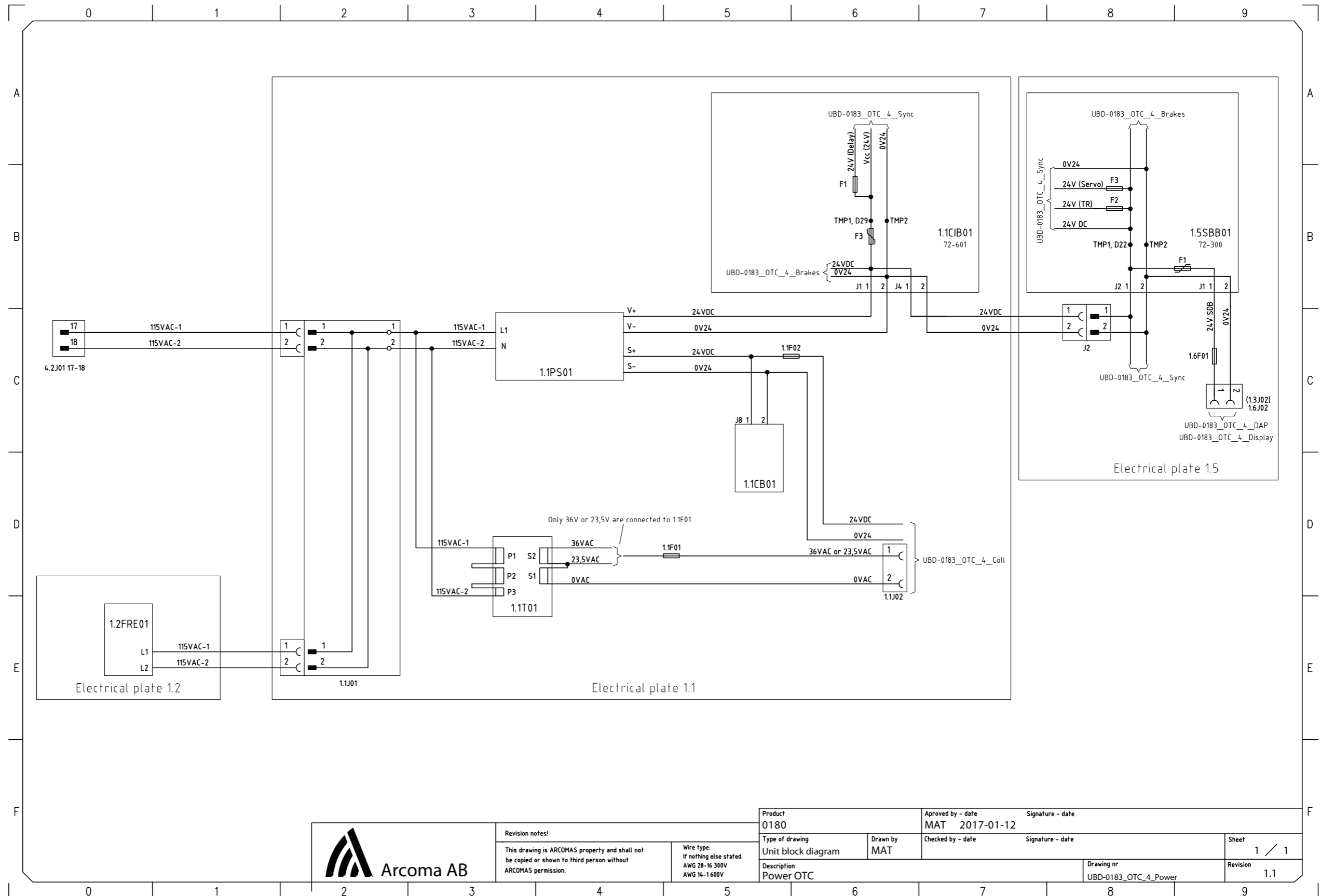

**Revision notes!**  
 This drawing is ARCOMAS property and shall not be copied or shown to third person without ARCOMAS permission.  
 Wire type:  
 If nothing else stated:  
 AWG 28-16 300V  
 AWG 14-1600V

Product 0180	Approved by - date MAT 2017-01-12	Signature - date
Type of drawing Unit block diagram	Drawn by MAT	Checked by - date
Description Power OTC	Drawing nr UBD-0183_OTC_4_Power	Sheet 1 / 1
		Revision 1.1



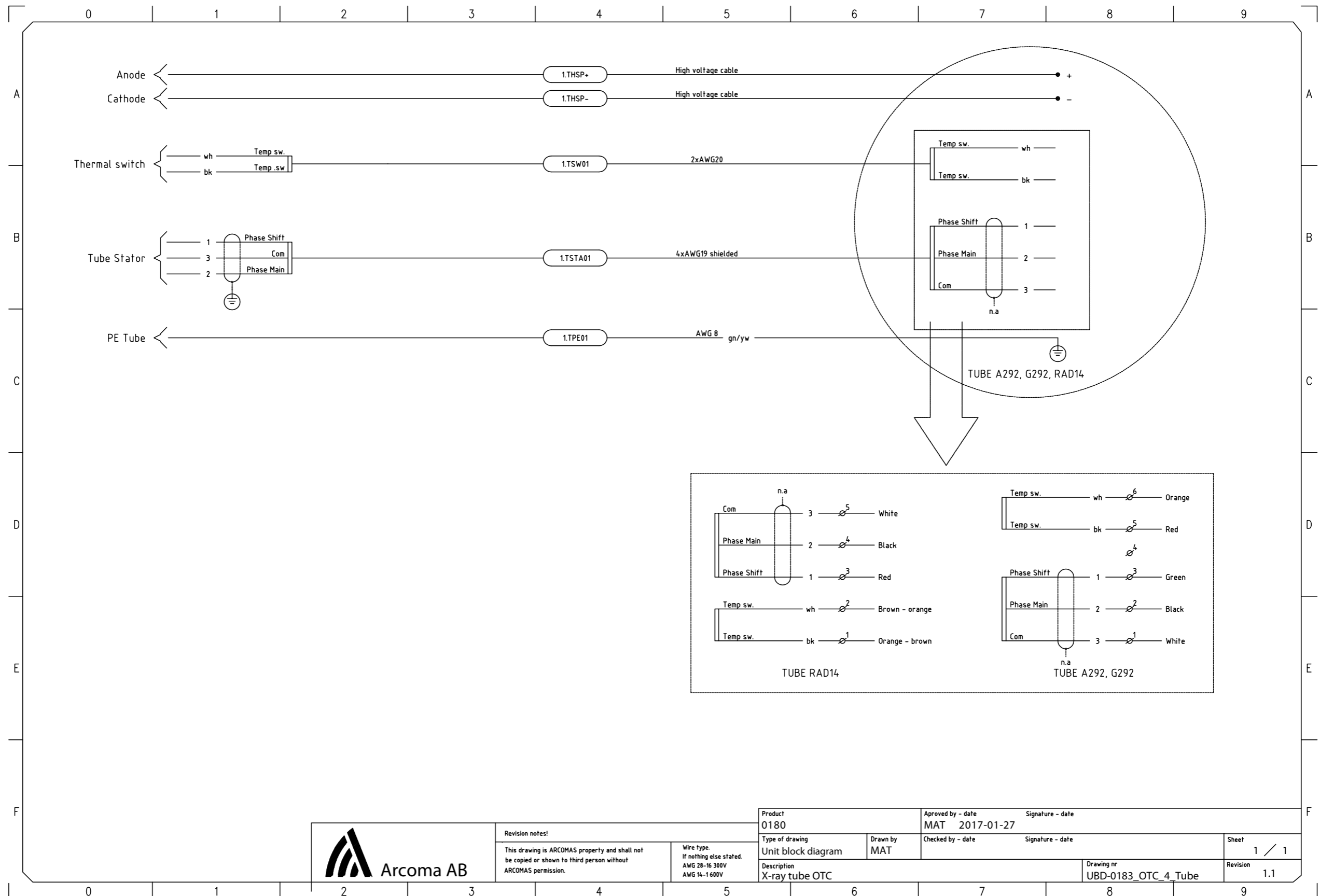

**Revision notes!**  
This drawing is ARCOMAS property and shall not be copied or shown to third person without ARCOMAS permission.

Wire type:  
If nothing else stated:  
AWG 28-16 300V  
AWG 14-1600V

Product 0180		Approved by - date MAT 2017-01-27		Signature - date	
Type of drawing Unit block diagram	Drawn by MAT	Checked by - date		Signature - date	
Description X-ray tube OTC				Drawing nr UBD-0183_OTC_4_Tube	Sheet 1 / 1
				Revision 1.1	



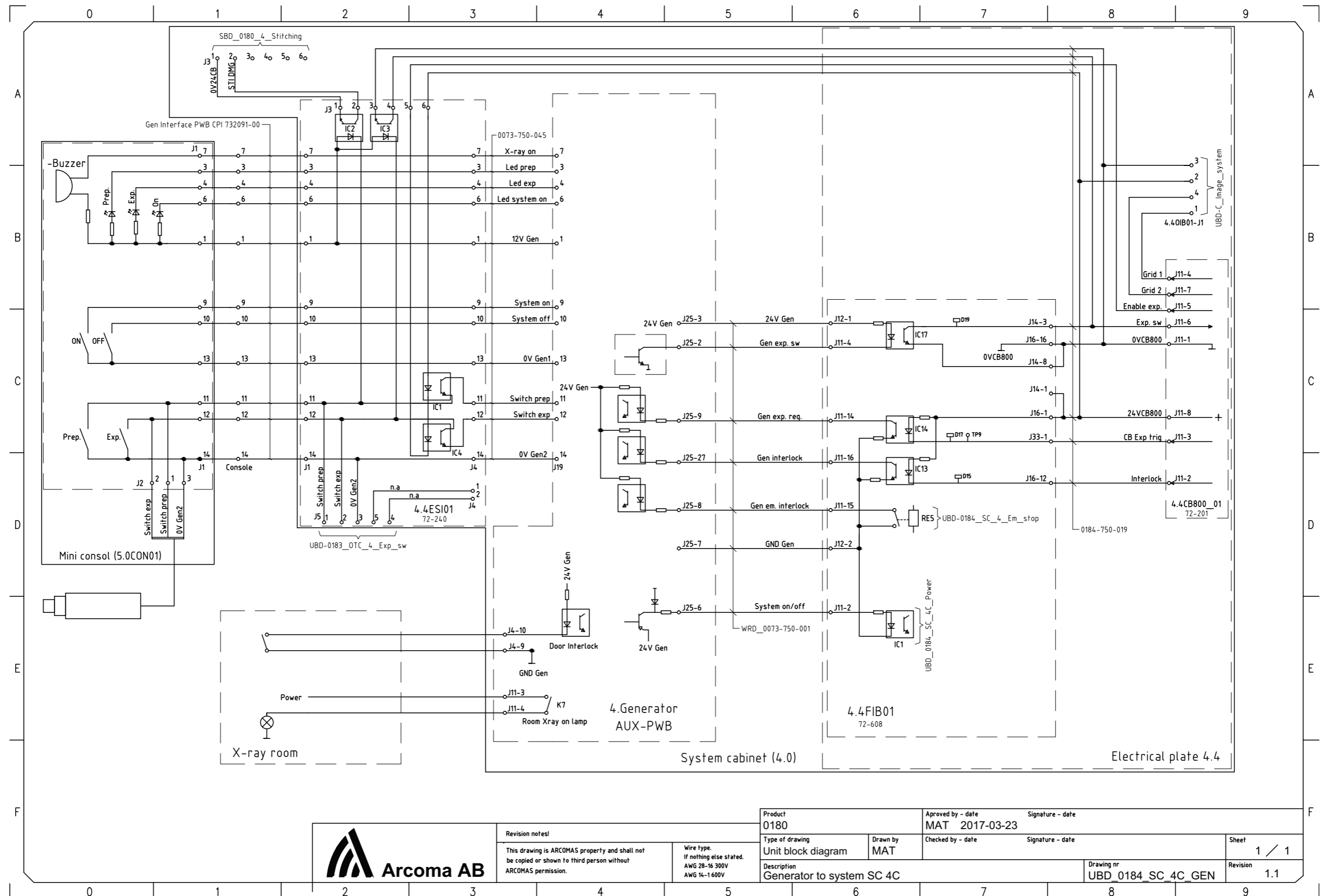

**Revision notes:**  
 This drawing is ARCOMAS property and shall not be copied or shown to third person without ARCOMAS permission.  
 Wire type:  
 If nothing else stated:  
 AWG 28-16 300V  
 AWG 14-1 600V

Product 0180	Approved by - date MAT 2017-03-23	Signature - date
Type of drawing Unit block diagram	Drawn by MAT	Checked by - date
Description Generator to system SC 4C		Drawing nr UBD_0184_SC_4C_GEN
		Sheet 1 / 1
		Revision 1.1



## 8 Fuses

The fuses part number, size, type, designation and function are listed in the table below. Turn off the power to the product when removing and replacing fuses. Replace only with the exactly same type of fuses.

### 8.1 OTC

Fuse chart electrical plate 1.1

Designation	Size	Type	Manufacturer	Function
1.1F01	10A	C60N 1P C10A	Schneider Electric/Merlin Gerin	Coll. Halogen lamp power
1.1F02	1.5A	326 series - SloBlo ceramic body 6.3x32 mm	Littlefuse	Coll. 24 VDC power

Fuse chart PCB 1.1CIB01

Designation	Size	Type	Manufacturer	Function
F1	100mA	217 series - Fast acting Glass body 5x20 mm	Littlefuse	Delay circuit table

Fuse chart PCB 1.5SBB01

Designation	Size	Type	Manufacturer	Function
F1	100mA	217 series - Fast acting Glass body 5x20 mm	Littlefuse	Delay circuit wall stand

Fuse chart 1.6

Designation	Size	Type	Manufacturer	Function
1.6F01	1.5AT	326 series - SloBlo ceramic body 6.3x32 mm	Littlefuse	Display 24 V power
1.6F02	0.5AT	313 series - SloBlo glass body 6.3x32 mm	Littlefuse	DAP 24V power

# Fuses

## System cabinet

---

### 8.2 System cabinet

Fuse chart electrical plate 4.2

Designation	Size	Type	Manufacturer	Function
4.2F01	C20A	C60N 3P C20A	Schneider Electric/Merlin Gerin	Mains power
4.2F02	C1A	C60N 1P C1A	Schneider Electric/Merlin Gerin	Internal 230 VAC
4.2F03	C6A	C60N 2P C6A	Schneider Electric/Merlin Gerin	Ceil 2x115 VAC
4.2F04	C6A	C60N 2P C6A	Schneider Electric/Merlin Gerin	Table 2x115 VAC
4.2F05	C6A	C60N 1P C6A	Schneider Electric/Merlin Gerin	Detectors 230 VAC



## 8.3 Two column table (option)

Fuse chart electrical plate 2.1

Designation	Size	Type	Manufacturer	Function
2.1F01	6A	C60N 1P C6A	Schneider Electric Merlin Gerin Eaton	24 VDC Logic

Fuse chart 2.1DC01 and 2.1DC02

Designation	Size	Type	Manufacturer	Function
2.1DC01-F1	15A	326 series - 3AG SloBlo glass body 6.3x32 mm	Littlefuse	36 VDC motor power
2.1DC02-F1	15A	326 series - 3AG SloBlo glass body 6.3x32 mm	Littlefuse	36 VDC motor power

# Fuses

## Wall stand Z manual

---

### 8.4 Wall stand Z manual

Fuse chart 4.4FIB01 placed in the system cabinet

Designation	Size	Type	Manufacturer	Function
4.4FIB01-F3	3AT	326 series - 3AB SloBlo ce- ramic body 6.3x32 mm	Littlefuse	WS 24 V Logic

### 8.5 Wall stand Z motorized

Fuse chart 4.4FIB01 placed in the system cabinet

Designation	Size	Type	Manufacturer	Function
3.1F01	10AT	326 series - 3AB SloBlo ce- ramic body 6.3x32 mm	Littlefuse	36 VDC Z- motor
3.1F02	3AT	326 series - 3AB SloBlo ce- ramic body 6.3x32 mm	Littlefuse	WS 24 V Logic

# Fuses

Wall stand Z motorized

---

## 9 Technical Specifications

### 9.1 400T System

#### 9.1.1 Electrical characteristics

Mains voltage for the system	400 V 3N, 50/60 Hz 400 V 3~ 480 V 3~ 150 A (Short term peak value), (required fuse 63 A thermal breaker, B-curve).
Heat dissipation	689 BTU/hr

For further information, see the Tube technical data sheet, at the accompanying documents.

#### 9.1.1.1 Classification

Classification according to IEC/EN 60601-1.

Class	Class I equipment. All dead metal parts of the equipment are electrical connected to protective earth.
Applied part	Type B
Protection against ingress of water	IPX0
Mode of operation	Intermittent operation: 20% 1 min ON / 4 min OFF
Use of anesthetic mixtures	The equipment is not suitable for use in the presence of flammable anesthetics mixtures with air, oxygen or nitrous oxide.

Classification according to IEC/EN 60601-1-2

Class	Class A
-------	---------

# Technical Specifications

## 400T System

### 9.1.1.2 Output parameters

OUTPUT PARAMETER	MODE	GENERATOR SERIES	LOADING FACTOR
Maximum X-ray tube voltage and highest X-ray tube current at that voltage.	Radiographic (Intermittent)	80 kW	150 kV, 500 mA
		65 kW	150 kV, 400 mA
		50 kW	150 kV, 320 mA
Maximum X-ray tube current and highest X-ray tube voltage at that current.	Radiographic (Intermittent)	80 kW	1000 mA, 80 kV
		65 kW	800 mA, 81 kV
		50 kW	630 mA, 80 kV
Combination of X-ray tube current and X-ray tube voltage resulting in highest output power.	Radiographic (Intermittent)	80 kW	800 mA, 100 kV
		65 kW	630 mA, 103 kV
		50 kW	500 mA, 100 kV
Highest constant output power at 100 kV, 0.1 sec.	Radiographic (Intermittent)	80 kW	80 kW (800 mA, 100 kV, 0.1 s)
		65 kW	63 kW (630 mA, 100 kV, 0.1 s)
		50 kW	50 kW (500 mA, 100 kV, 0.1 s)
Nominal shortest irradiation time (AEC exposure).	AEC	All models (AEC control is available over the full kV and mA range)	15 ms. AEC control is achieved by varying the ms of the exposure.  The AEC ms range is 15 ms to an installer-programmable maximum not to exceed 600 mAs.

### 9.1.2 Environmental requirements

Ambient transport and storage temperature	-40 °C - +70 °C
Ambient operating temperature	+10 °C - +40 °C
Transport and storage humidity (relative)	10-90%, non-condensing
Operating humidity (relative)	30-75%, non-condensing
Maximum transport and storage altitude	500-1060 hPa
Maximum operating altitude	700-1060 hPa

### 9.1.3 OTC

#### 9.1.3.1 General

Rotation range ceiling (beta)	- 193°(±5°) ~ +155°(±10°)
Rotation range tube arm (alpha)	+193°(±5°) ~ -155°(±10°)
Column (Z stroke)	1700 mm, 1450 mm

#### 9.1.3.2 Weight

OTC	127 kg
Tube and collimator	40 kg maximum allowed weight
Traverse rail X	60 kg
Ceiling rail Y (4 m standard)	16 kg

#### 9.1.3.3 Speed

	Low speed	Maximum speed
Z movement	40 mm/s	150 mm/s

# Technical Specifications

## 400T System

---

### 9.1.4 Cabinet

#### 9.1.4.1 General

Dimensions (L x W x H) mm	750 x 610 x 1130
---------------------------	------------------

### 9.1.5 Wall stand

Column, Z stroke	1470 +40/-10 mm (non-tilt)
------------------	----------------------------

Rotation range detector holder wagon (Only the tiltable detector holder wagon).	-20° - 90°
---	------------

#### 9.1.5.1 Attenuation Equivalent

Detector holder	$\leq 0.6$ mm
-----------------	---------------

#### 9.1.5.2 Weight

Wall stand	Maximum 180 kg (160 +20/ -20 kg)
Detector	Maximum 40 kg



### 9.1.6 Closed table 0181

#### 9.1.6.1 Maximum patient load

Maximum patient load	295 kg
----------------------	--------

#### 9.1.6.2 Weight of parts

Table (with table top and vertical lift)	241 kg
Table top	47 kg
Vertical lift	14 kg

#### 9.1.6.3 Vertical lift

Lowest table top position (from the floor to the table top surface)	540 +20/-10 mm
Z stroke	310 +40/-20 mm
Maximum travel speed	25 mm/s (MRS $\geq$ 30 mm/s)

#### 9.1.6.4 Table top

Dimensions	2400 mm X 800 mm
X-ray transparent area	2350 mm X 580 mm
Thickness	21 mm
Length of stroke X-direction from center position (Longitudinal)	$\pm$ 500 +20/-10 mm
Length of stroke Y-direction from center position (Lateral)	$\pm$ 150 +20/-10 mm
Aluminium equivalence	$\leq$ 0.9 mm
Aluminium equivalence cover detector holder	< 0.6 mm

#### 9.1.6.5 Detector holder

Weight	Maximum 40 kg
Size (maximum)	D600 mm x W620 mm x H95 mm

# Technical Specifications

## 400T System

---

### 9.1.7 Two column table 0055 (option)

#### 9.1.7.1 Column

Two column table, with motorized vertical movement

Lowest table top position (from the floor to the table top surface)	550 mm
Column (Z stroke)	380 mm

#### 9.1.7.2 Table top

Two column table with manual or motorized detector movement

Dimensions	2400 mm X 853 mm
X-ray transparent area	2400 mm X 601 mm
Thickness	21.5 mm
Length of stroke, X-direction	+/- 600 mm
Length of stroke Y-direction	+/- 150 mm
Movement range of the detector	up to 850 mm
Aluminum equivalence	0.9 mm
Aluminum equivalence cover detector holder	< 0.6 mm

#### 9.1.7.3 Weight

Two column table, compl.	Maximum 147 kg
Table top	Maximum 47 kg
Maximum patient load	300 kg

## 10 Options

### 10.1 General



#### **WARNING!**

---

*Risk of squeezing during motorized movements.*

*Only accessories approved by the manufacturer are allowed for the system.*

---

This chapter describes options that can be ordered for the system.

# Options

## Options for the system, with Canon image system

---

### 10.2 Options for the system, with Canon image system

#### 10.2.1 Ceiling Suspended X-ray Tube Support, Canon US

Part no.	Ceiling height	Vertical column stroke	Description
0170-925-029	2.5 to 2.7 m	1450 mm	3x5m, low ceiling version
0170-925-032	2.7 to 2.85 m	1450 mm	3x5m
0170-925-033			4x5m
0170-925-034			Special order: X(<4m)0 Y(<4m)=0
0170-925-040	Over 2.85 m	1700 mm	3x5m
0170-925-030			4x5m
0170-925-031			Special order: X(<4m)0 Y(<4m)=0
0170-925-003	>2.5 — 2.8 m	1450 mm	Installation cube low ceiling 3x4m
0170-925-016	>2.8 m	1700 mm	Installation cube low ceiling 3x4m
0170-925-039	16 m High voltage cables		
0170-925-005	24 m High voltage cables		
0170-925-006	Extra mechanical index in ceiling rails for positioning (2 pieces)		
0540-925-010	400 kHU X-ray tube, 40/100kW, 150 kV		
0540-925-011	600 kHU X-ray tube, 40/100kW, 150 kV		
0540-925-014	Automatic collimator and collimator handle for WS		
0540-925-022	Automatic collimator with LED and collimator handle for WS		

#### 10.2.2 Options for Table

##### 10.2.2.1 Closed Table 0181

Part no.	Description
0180-925-116	Mechanical index for manual detector movement

### 10.2.2.2 Optional Table

Part no.	Description
0180-925-117	Two column table Specification <ul style="list-style-type: none"> <li>• Motorized elevation (555 - 930 mm)</li> <li>• Patient load 250 kg</li> <li>• Floating table top</li> <li>• Manoeuvre handle (Up/Down, Table top release)</li> </ul>

### 10.2.2.3 Two column table

Part no.	Description
0170-925-101	Vertical collision protection, option
0170-925-103	Mechanical index for manual bucky movement

### 10.2.3 Options for Wall Stand

Code	Description
0180-925-201	No Wall stand tilt
0180-925-202	Wall stand tilt
0180-925-225	Manual movements of detector
0180-925-224	Motorized movement of detector
0072-925-006	WS: Foot control Release of brake for manual vertical movement

### 10.2.4 Detectors

The following detector options are available for the System

Prepared for:

- CXDI 401C compact
- CXDI-701C, 710C, 702C Wireless - detector rotation
- CXDI-401C, 410C, 402C Wireless
- CXDI-701C, 710C, 702C - Automatic battery charging when loading the detector.
- CXDI-401C, 410C, 402C - Automatic battery charging when loading the detector.

# Options

## Options for the system, with Canon image system

---

### 10.2.5 System cabinet

Code	Description
0072-925-302	50 kW, 100 kHz — 200 kHz High frequency generator
0072-925-300	65 kW, 100 kHz — 200 kHz High frequency generator
0072-925-301	80 kW, 100 kHz — 200 kHz High frequency generator

### 10.2.6 Other options

Code	Description
0170-925-014	Integrated DAP for automatic collimator
0170-925-041	DAP for manual collimator
0170-925-007	Electrical and mechanical index for positioning (2 pcs)
0170-925-307	External emergency stop

### 10.2.7 Canon integration

Code	Description
0072-925-149	<i>2 detectors:</i> Wall stand CXDI-701C Wireless Table CXDI-701C Wireless
0072-925-157	<i>2 detectors:</i> Wall stand CXDI-701C Wireless Table CXDI-401CW Wireless
0072-925-158	<i>2 detectors:</i> Wall stand CXDI-701C Wireless Table CXDI-401CW Wireless
0072-925-159	<i>2 detectors:</i> Wall stand CXDI-401CW Wireless Table CXDI-401CW Wireless
0072-925-160	<i>2 detectors:</i> Wall stand CXDI-401CW Wireless Table CXDI-701C Wireless

# Options

## Options for the system, with Canon image system

---

Code	Description
0072-925-161	2 detectors: Wall stand CXDI-401CW Wireless Table CXDI-401C Compact
0072-925-162	2 detectors: Wall stand CXDI-401C Compact Table CXDI-401C Compact
0072-925-163	2 detectors: Wall stand CXDI-401C Compact Table CXDI-701C Wireless
0072-925-164	2 detectors: Wall stand CXDI-401C Compact Table CXDI-401CW Wireless
0072-925-007	2 detectors: Wall stand CXDI-710C Wireless Table CXDI-410C Wireless
0072-925-008	2 detectors: Wall stand CXDI-710C Wireless Table CXDI-410CW Wireless
0072-925-009	2 detectors: Wall stand CXDI-710C Wireless Table CXDI-401C Compact
0072-925-016	2 detectors: Wall stand CXDI-410CW Wireless Table CXDI-410CW Wireless
0072-925-017	2 detectors: Wall stand CXDI-410CW Wireless Table CXDI-710C Wireless
0072-925-018	2 detectors: Wall stand CXDI-410CW Wireless Table CXDI-401C Compact
0072-925-019	2 detectors: Wall stand CXDI-401C Compact Table CXDI-710C Wireless

# Options

## Options for the system, with Canon image system

---

<b>Code</b>	<b>Description</b>
0072-925-020	<i>2 detectors:</i> Wall stand CXDI-401C Compact Table CXDI-410CW Wireless
Charging in detector holder	
0072-925-170	Charging in detector holder in wall stand (CXDI 401CW/410CW wireless or CXDI 701C/ 710C wireless must be selected for wall stand)
0072-925-171	Charging in detector holder in table (CXDI 401CW/410CW wireless or CXDI 701C/ 710C wireless must be selected for table)
<b>Wall stand loading</b>	
0180-925-203	Left-hand loading
0180-925-204	Right-hand loading



### 10.3 Cube Installation

Install the brackets (1) into the four traverse beams (2).

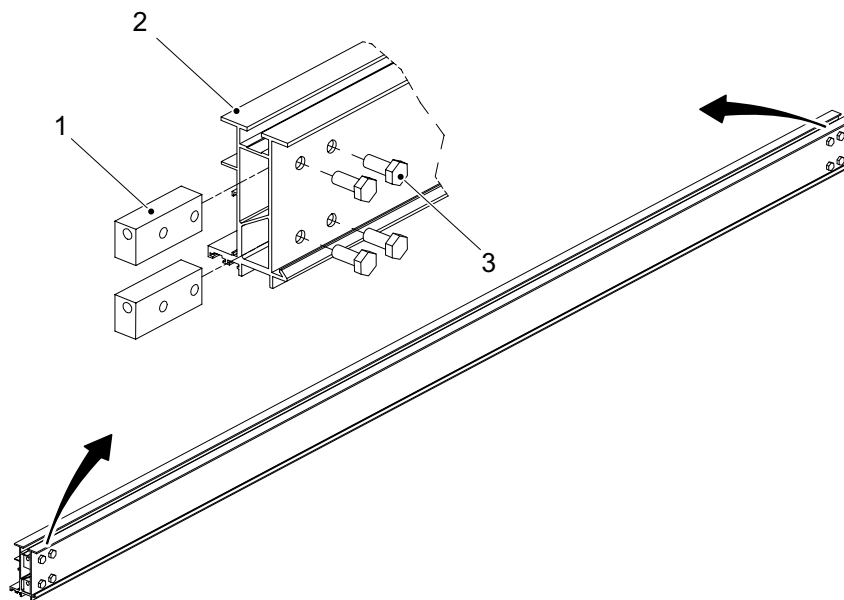

*Fig. 10-1 Installing brackets*

1. Bracket
2. Traverse beam
3. Screw M10x25

**Note!**

- Rotate the brackets 180 degrees, and mount them so that the holes on the left side are facing down.
-

# Options

## Cube Installation

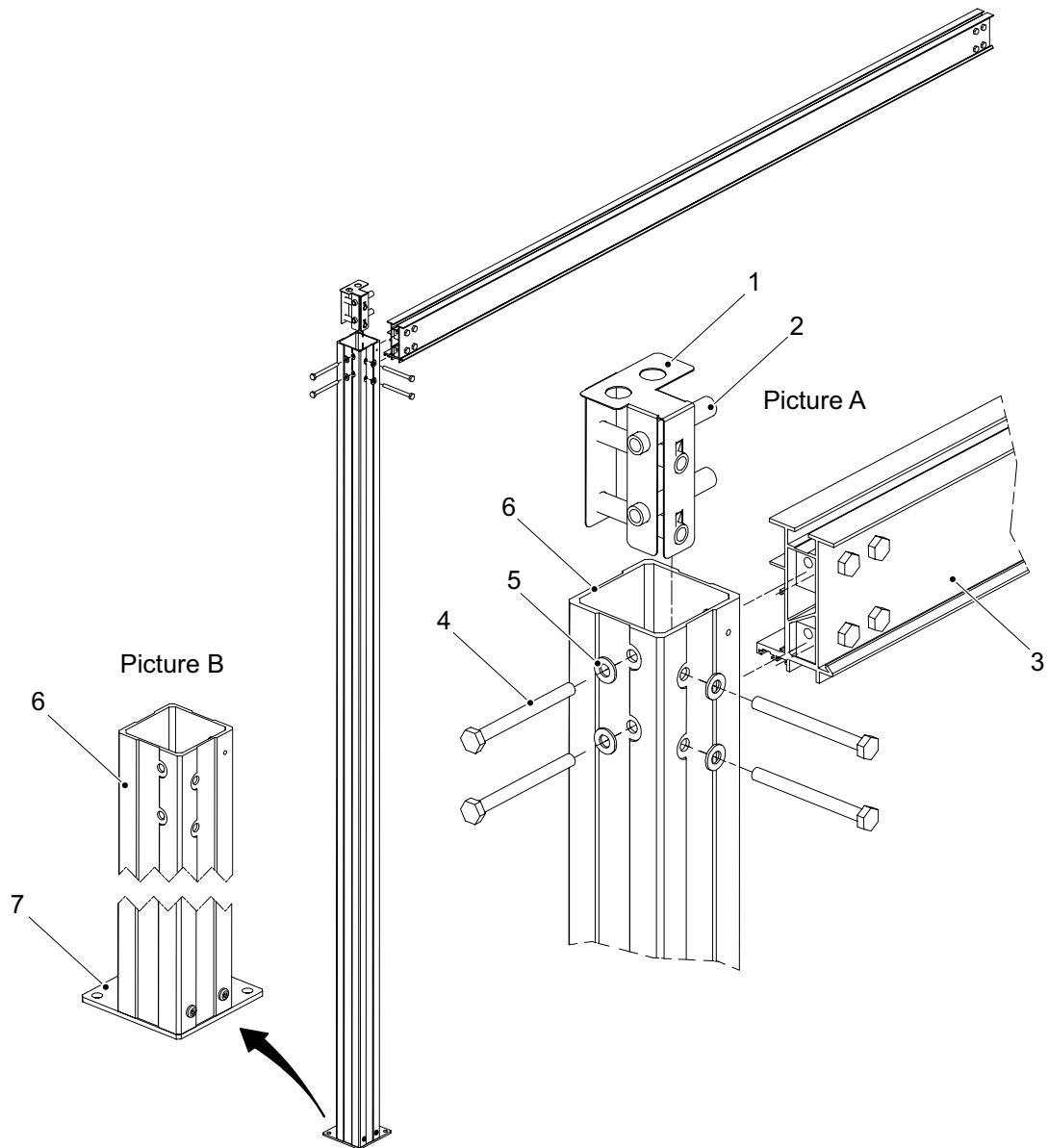

Fig. 10-2 Installing columns

1. Angle
2. Housing
3. Traverse beam
4. Screw
5. Washer
6. Column
7. Base

Install the housing (2) into the angle (1) and place the angle into the column (6), see picture A in Fig. 10-3 *Installation cube*.

Repeat this part on all four columns.

Install the two short traverse beams (3) on two columns each, be aware of the direction on the base (7) of the columns, according to picture B in Fig. 10-3 *Installation cube*.

Install the two long traverse beams in the same way as the short traverse beam, see Fig. 10-3 *Installation cube* and Fig. 10-4 *Installing wall attachment*.

The corners of the installation cube must be in angle of 90°. To achieve angle of 90° measure in a cross from corner to corner, the measurement may differ  $\pm 5$  mm.

**Note!**

*The installation cube shall also be parallel  $\pm 1$  mm.*

---

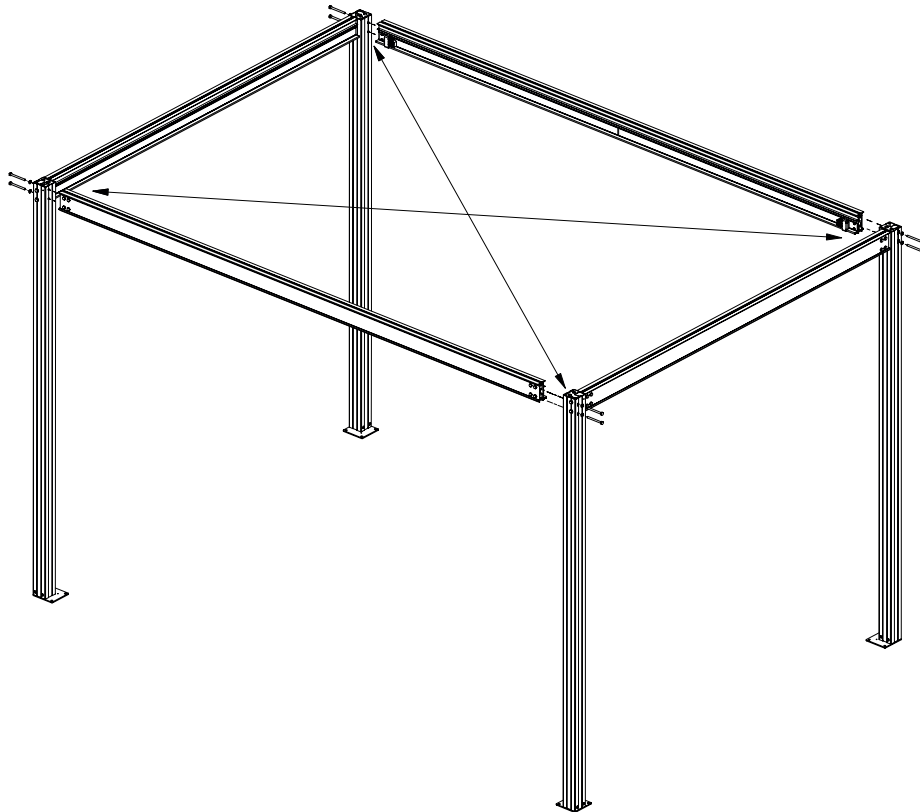

*Fig. 10-3 Installation cube*

Install the wall attachment on the installation cube, see Fig. 10-4 *Installing wall attachment*. The wall attachment allows a placement of the installation cube 0-1000 mm from the wall.

# Options

## Cube Installation

---

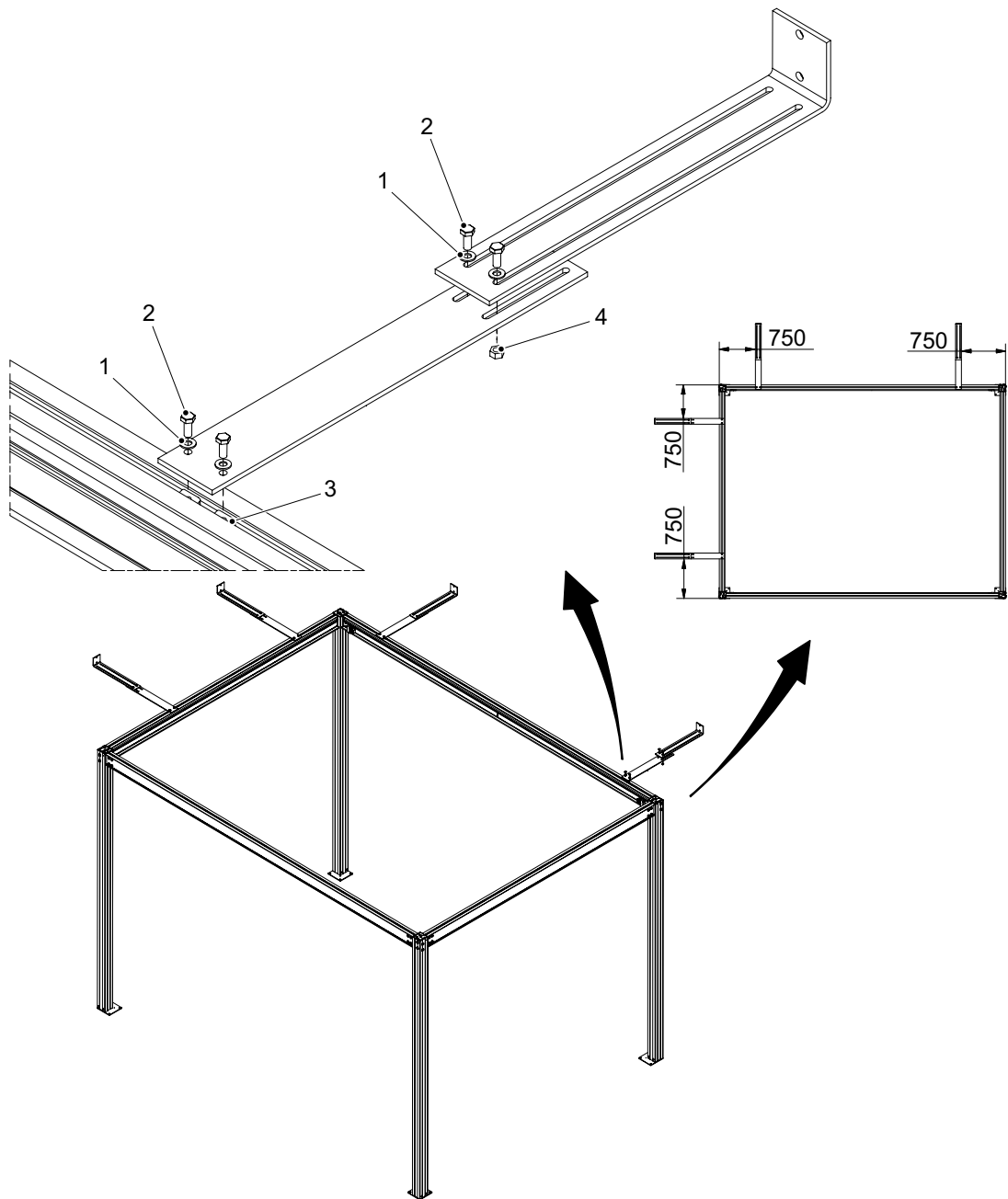

Fig. 10-4 Installing wall attachment

1. Washer
2. Screw
3. Rhomb nut
4. Nut

Place the installation cube over the center-drilled holes and install the insulation plates and cases on the base of the column according to Fig. 10-5 *Column base*.

Place a spirit level on the vertical and horizontal beams of the installation cube and check that the beams are vertical and horizontal  $\pm 1^\circ$ . Shim if necessary.

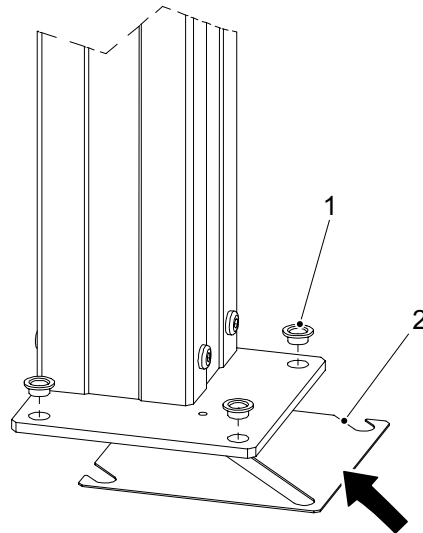

Fig. 10-5 *Column base*

1. Insulation case
2. Insulation plate

Install the wall attachment, insulation plates and the installation cases into the wall.

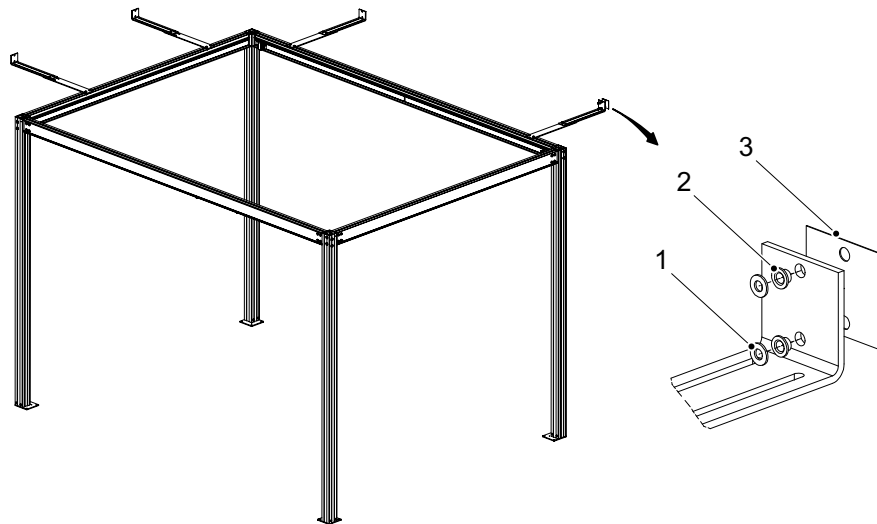

Fig. 10-6 *Installing into the wall*

1. Insulation case
2. Washer
3. Insulation plate

# Options

## Cube Installation

---

## 11 Accessories



### **WARNING!**

***Risk of squeezing during motorized movements.***

***Only accessories approved by the manufacturer are allowed for the system.***

This chapter describes accessories that can be ordered for the system.

### 11.1 Accessories

Code	Description
<b>General</b>	
0512-099-001	Unistruts Rails 4x4
0512-099-002	Unistruts Rails 4x5
0512-099-003	Mounting Kit Unistruts Rails 4x4
0512-099-004	Mounting Kit Unistruts Rails 4x5
0072-099-309	Mobile Stitching Screen
0170-099-002	Cable Outlet for 0170-CS
<b>Wall stand</b>	
0072-099-306	Patient lateral armrest
0540-151-010	Foot pedal, Z-movement (maximum 2 pieces)
0180-099-050	Grid 40 lp/cm, R10:1, F115
0180-099-051	Grid 40 lp/cm, R10:1, F150
0180-099-052	Grid 40lp/cm, 10:1 Ratio, SID 180, Alu type
0180-099-076	Grid 52 lp/cm, R10:1, F140, Alu type
0180-099-061	Grid 51 lp/cm, R10:1, F180, Alu type
0182-099-320	Wall bracket
0175-099-002	Cable Outlet for WS
<b>Table</b>	
0055-099-170	Patient Kit: Compression belt Cost effective, Patient handgrip (2 pieces) and Mattress
0055-099-014	Patient Handgrip (1 piece)
0055-099-028	Compression belt Cost effective

# Accessories

## Accessories

---

0055-099-029	Compression Belt High-end
0080-099-051	Form pad Small — Rectangle
0080-099-050	Form pad Medium — Wedge
0080-099-052	Form pad Large — Head
0055-099-011	Lateral Cassette/Detector holder
0180-099-051	Grid 40 lp/cm, 10:1 Ratio, SID 150 Alu type
0180-099-060	Grid 52lp/cm, 10:1 Ratio, SID 110 Alu type
0180-099-076	Grid 52lp/cm, 10:1 Ratio, SID 140 Alu type
0181-099-008	X/Y/Z manoeuvre handle
0181-099-009	Hand control for Automatic Collimator (1 piece)
0181-099-005	Additional Foot pedal
0055-099-007	Mattress 2200 mm
	Two column table
0072-099-004	Foot control (Up/Down, Table top release)
0055-099-025	Foot control strip type (Table top release)
0055-099-009	Hand control for automatic collimator (1 pc)
<b>Components</b>	
0180-099-301	Complete System Cabinet with 65kW Generator
0180-099-302	Complete System Cabinet with 80kW Generator
0180-099-310	Complete Transverse with Bridge and Y-rails 4x5 m.



## 12 Spare Parts

To find and identify spare parts, see 2000-095-072 X.X SPL Catalogue.

# Spare Parts

---

## 13 Waste disposal

The manufacturing company is responsible for disposal of the product. To avoid environment pollution and human injury, we therefore request that you contact the Manufacturer or your dealer if you wish to cease operation of your product with the intention of disposal.

For disposal of other components, refer to corresponding documentation.

Please follow the rules and regulations of your relevant authorities in the disposal of this product, accessories, options, consumables, media and their packing materials.

# Waste disposal

---

## 14 Appendix A

### 14.1 Glossary

#### A

Accessories	Extra facilities to the product which easily can be mounted by the user.
AEC	Automatic Exposure Control
Alpha	A direction for a rotation movement.

#### B

Beta	A direction for a rotation movement. The tube turns around the Z-axis.
Btu/hr	British thermal unit/hour
BU/Back-up	A precautionary measure that shuts off the exposure, if the AEC chamber does not.
Bucky	See Detector holder.

#### C

CE	A CE-marked product verifies that the Manufacturer guarantees that the product fulfils the EU fundamental health, environment and security requirements.
Centering	The field of image is centered over the detector.
Collision	Either a physical collision with an obstacle or the node cannot reach its end position.
CR	Image plates.

#### D

DAP meter	Dose Area Product meter. The DAP-meter is placed next to the collimator and measures the amount of X-ray radiation that leaves the collimator.
Diode	Electrical component that leads voltage and current in one direction.
Dealer	See "Supplier".
Detector	Image receptor for X-ray that does not require a cassette. The reception and transfer of an image is digital.

#### E

# Appendix A

## Glossary

---

EMC	Electromagnetic Compatibility.
End stop	See mechanical end stop and software end stop.
Exposure	An image is taken against an image receptor.
<b>F</b>	
<b>G</b>	
Guard function	Collision detection of the Z-movement (option).
Guard sensor	A sensor in the top of the Z-column that registers variations of force.
<b>H</b>	
<b>I</b>	
IEC	International Electrotechnical Commission.
Image receptor	Receptor for images; Film, CR, DR or Cassette.
Image receptor holder	Holder for the image receptor (Film, CR, DR or Cassette).
Index	Mechanical position markings, for instance alpha 0°, +90° and -90°.
Intermittence	The number of repetitions / unit of time. Recurrent cycles.
ISO	International Organization for Standardization.
<b>J</b>	
<b>K</b>	
<b>L</b>	
<b>M</b>	
Mechanical end stop	A physical device that stops an automatic or manual movement if the software end stop is out of order.
Motorized movement	A motor assisted movement.
<b>N</b>	
Node	A control and supervision unit, consists of printed circuit board and node specific software.
<b>O</b>	

O.D.	Optic Density.
Options	Extra facilities that demand updating of the System software and hardware before use. Options demand installation of an authorized service technician.

### P

Position	A location in the room (X, Y and Z ).
----------	---------------------------------------

### Q

### R

### S

SID	Source to image distance. The distance between the focus spot in the X-ray tube and the active image receptor surface. FFD is also used.
Software end stop	A non-physical device that stops an automatic or manual movement. The software end stop is placed before the mechanical end stop.
SSW	Service software.
Supplier	The company that sells the System to the user (hospital).

### T

Table frame	The metallic frame that carries the Table top. The frame is attached to the bottom of the Table top.
-------------	--

### U

### V

### W

Working area	The size of the Table top including X- and Y-stroke.
--------------	--

### X

X-movement	The System moves in the X-direction.
------------	--------------------------------------

### Y

Y-movement	The System moves in the Y-direction.
------------	--------------------------------------

### Z

# Appendix A

## Glossary

---

Z-node	The Z-node controls the Z-movement.
Z-movement	The System moves in the Z-direction.



## **15 Appendix B**

### **15.1 Checklists**

Make a copy of this form before filling in.

If there is any discrepancies, use the Remark table to make a note.

Hospital:.....

ID No:.....

Sign:.....

# Appendix B

## Checklists

---

### 15.1.1 Annual Checklist

Make a copy of this form before filling in.

If there is any discrepancy please use the remark table to note them.

Hospital:.....

ID No:.....

Sign:.....

#### 15.1.1.1 OTC

- 1. Clean all tracks for wheels and bearings.
- 2. Check that the installation bolts for the ceiling rails Y are tightened properly with 15 Nm. If any bolts are loose, use Loctite 243 and tighten with 24 Nm.
- 3. Check that the installation bolts (12 pcs) for the distance plates, at the ceiling rails Y, are tightened properly with 10 Nm. If any bolts are loose, use Loctite 243 and tighten with 24 Nm.  
Check that there is no play between the traverse rails X, distance plates and the wheel holders, see picture A and B.
- 4. Check that the installation screws (2) for the turning plate are tightened properly with 10 Nm. If any screw is loose, use Loctite 243 and tighten with 24 Nm. To reach the screws, remove the cover (1) under the column and push the cover upward and check the screws (2).  
Check that there is no play between detail 3 and 4 according to picture A and B.
- 5. Remove the tube cover and check that the installation screws are tightened properly with 10 Nm. If any screw is loose, use Loctite 243 and tighten with 24 Nm.  
Check also the screws for the collimator installation. How this is done depends on collimator type.
- 6. Take hold of the collimator and move the collimator gently to feel if it is loose.  
Also check that there is no play between the collimator and the X-ray tube. If the collimator is the slightest loose or if there is a play between them, tighten the 3 screws.

- 7. Check the lifting cord for damage and make sure that it runs smoothly. It might be a subject for exchange when the tension gets too low. Also check the attachment point of the lifting cord.
  
- 8. Check the functions of the safety switches according to electrical drawing UBD\_0170\_Sync\_DMG\_01.
  
- 9. Check the safety switches in the column by using the following procedure: Press the downward button and stop the movement by applying force.  
 Note that force applied needs to exceed the weight of the tube assembly approx. 35 kg). The movement shall stop when force is applied.  
 To move the System upward, the switches has to be activated, the column chains must be straightened.
  
- 10. a) Press the synchronization control (1) on the Wallstand. The diode D17 (C) on 1.5SBB01 will light up, see picture B. The diode will not light up when the synchronization control is not activated.  
 b) If there is a foot pedal present;  
 Press the foot pedal the diode D17 (C) on 1.5SBB01 will light up, see picture B. The diode will not light up when the foot pedal is not activated.
  
- 11. Check the safety switch alpha by tracking the Wallstand. The OTC shall follow the Wallstand the whole stroke.  
 If the OTC stops at the safety height check the safety switch alpha.
  
- 12. When the column drives upward the contactor shall be activated and when the movement is stopped the contactor shall release.
  
- 13. Check all outer cabling for damage.
  
- 14. Check protective earth.  
 Enter the measured values in the Safety checklist, Appendix B.
 

Measured value:
..... Ω
..... Ω
..... Ω
  
- 15. Check the emergency stop, by activating the emergency stop during motorized movement. The display of both the OTC and the image display shall show a message when the emergency stop is activated and all motorized movements are inhibited.
  
- 16. Check the column segments of the OTC (full stroke). It should run smooth and without dissonance.  
 Lubricate the columns with BP Energol GR-XP 220, if necessary.

# Appendix B

## Checklists

---

- 17. Check the brake for the column motor by running the column in Z direction. The brake shall activate when the movement stops.
- 18. Move the OTC manually to all positions in X, Y and Z directions and make sure it runs smoothly and sounds OK.
- 19. Turn on the collimator light and position the center of the collimator light field against a horizontal detector.  
Drive the column upward/downward. The center of the collimator light field must stay on the same spot.  
Check that the readouts for the tube angulation is 0°.
- 20. Perform the Alignment of OTC. Check that the readouts for the tube angulation is 90°.
- 21. Check the alignment of the light field and X-ray light field according to "Collimator light Alignment", in Chapter 4.
- 22. Check the function of the buttons on the maneuver handle.
- 23. If the System is cassette based and the detector is not present; check that you will get information on the generator console. See "Collimator light alignment" in Chapter 4.
- 24. Correspondence between x-ray field and image reception area.  
See *Correspondence Between X-ray Field and Image Reception Area* chapter 4.
- 25. Choose Table position and make sure tracking is activated.  
Measure between the X-ray tube focal spot and the active image receptor surface of the detector. The measured SID shall correspond with the displayed SID. The SID is allowed to differ  $\pm 1\%$ .
- 26. Verify the receptor indication light function on both Wallstand and Table according to Chapter 3 3.3.1.3 *Exposure Control*, Page 47.
- Check the function of the DAP meter.
- 27. Verify that the measured DAP value (Area dose:dGycm<sup>2</sup>) is shown in the Image system. "DAP value (Area dose:dGycm<sup>2</sup>)" is displayed in "Exp.Info: Irradiation results" of "Exposure screen control panels". Refer to Operator's Manual.
- 28. Verify the alpha angle.

### 15.1.1.2 Table 0181

- 1. Attach the safety clamp in maintenance position C. Be sure that the attachment is well secured in the bottom plate.
- 2. Check for abnormal sound.
- 3. Check for oil leaks.
- 4. Check for fallen foreign matter.
- 5. Check that the bolts fixing the Table to the floor are properly tightened.  
If there are evidence that the attachment in the floor has been damaged. Order new bolts from the Manufacturer and exchange the floor attachment.
- 6. Move the Table in X, Y and Z directions and make sure it runs smoothly and sounds OK.
- 7. Check the table top brakes:
  - Move the brakes in X or Y direction. The table top should run smoothly in X or Y direction whenever the brakes are released.
  - Lock the brakes and place a dynamometer against the table top and push slowly, it should be impossible to move the table top with a force less than:
    - Y-direction < 300 N
    - X-direction < 250 N
  - When there is no power to the table top, all brakes shall be applied.
  - Check the cables to the table top brakes.
- 8. Clean the profiles at the sides of the table top.
- 9. Clean the profiles for the image receptor tray movement.
- 10. Check the installation of internal cabling underneath the covers.  
Check the cable ties and that the cables are in right position.  
The harness should go under the metal part.
- 11. Check all internal and external cabling for damage. Squeezing and wear damages.
- 12. Lubricate the screw of the lifting unit with grease. Use grease *Klüber Duotempi PMY45*.  
Always order the grease from the manufacturer.  
To best get to the screw drive the Table to the highest position.  
Use a brush to apply the grease.

# Appendix B

## Checklists

---

- 13. Check protective earth according to 4.23.2 *Measure Protective Earth*, Page 198.  
Enter the measured values in the Safety checklist, Appendix B.  
Measured value:  
..... Ω  
..... Ω  
..... Ω  
..... Ω
- 14. Check status of critical circlips.
- 15. Check the screws of both mechanical end stops on the table top.  
If any screws are loose, tighten them.
- 16. Check both mechanical stops of the lifting unit.  
Check if the clamp is loose, tighten if necessary.
- 17. Check both Emergency stop buttons on the Table. By activating the emergency stop all motorized movements are locked.
- 18. Check the vertical travel safety of the table top.  
Hold and restrain at the same time as moving the table top up or down. The travel safety will then stop the movement of the table top in the on going direction.
- 19. Check the function of the movements in X/Y/Z by pressing the buttons on all the controls. The buttons shall not be damaged or get stuck when they are pressed.
- 20. Check the indication light, by choosing the Table mode.  
Make sure the table indication light is lit.
- 21. Check the function of the AEC chamber, and calibrate if necessary.

### 15.1.1.3 Two column table (option)

- 1. Check the tightening of bolts fixing the table to the floor. \_\_\_\_\_ (Nm)
- 2. Check the function and clean the table top ball bearings.
- 3. Clean the table top profiles.
- 4. Clean the profiles for the image receptor tray and detector wagon wheels.
- 5. Check the cabling to the table top brakes.
- 6. Check the condition of the table top brake pads.
- 7. Check the X-Y function of the table top brakes. X: \_\_\_\_\_ (Nm)  
Y: \_\_\_\_\_ (Nm)
  
- 8. Check the column segments on the table (full stroke).
- 9. Check the buttons on the foot control X/Y/Z.
- 10. Batteries in the wireless foot control (option).
- 11. Check the table guard function (option). \_\_\_\_\_ (Nm)

# Appendix B

## Checklists

---

### 15.1.1.4 Wallstand

- 1. Check for abnormal sound.
- 2. Check for fallen foreign matter.
- 3. Check that the bolts that fix the Wallstand to the floor are tightened properly, if not, tighten them.
- 4. Check the function of the AEC chamber, and calibrate if necessary.
- 5. Check the indication light, by choosing Wallstand mode on the image display.  
Make sure the Wallstand indication light is lit.
- 6. Check all cables for damage.
- 7. Clean all outer surfaces.
- 8. Make sure that the Operating instructions are available.
- 9. **Check lifting mechanism of Wallstand.**  
Remove the back cover, see 4.18.4 *Remove Back Cover*, Page 157.

**CAUTION!** \_\_\_\_\_  
**Secure the Wallstand with a locking device.**

---

There is no need to dismount the front cover.

- 10. The lift mechanism should be balanced and run smooth, without any sound.
- 11. Check the condition of the two lifting chains, the six chain locks and the attachment points of the chain, see Fig. 5-7 *Check points A and B*.  
Adjust if necessary.
- 12. Check the attachment points of the counterweights, see Fig. 4-67 *Loosen screws*.
- 13. Check the circlips (two) that secure the yoke to the axis. They should be in position, see Fig. 5-7 *Check points C*.
- 14. Check the mechanical end stops for the Z-movement. Check that they are intact and in position. There are four stops, two at the top and two at the bottom of the column.
- 15. Check the function of the brake. When the brake is released move the Wallstand up and down and the movement should stop.
- 16. Check protective earth according to 4.23.2 *Measure Protective Earth*, Page 198.  
Enter the measured values in the Safety checklist Appendix B.  
Measured value:  
..... Ω  
..... Ω
- 17. Check the Emergency stop buttons on the Wallstand.  
By activating the emergency stop all motorized movements shall be inhibited.  
The image display will display a message when the emergency stop is activated.



### Wallstand, Tilttable wagon

- 18. Check the function of the gas springs for the tilt. The maximum force should be 50 Nm.
- 19. Check that the two mechanical end stops are intact. There are two stops located on the wagon.

# Appendix B

## Checklists

---

### 15.1.1.5 Remark

	Remark	Action	Int note
No.			
1.	<hr/>	<hr/>	<hr/>
2.	<hr/>	<hr/>	<hr/>
3.	<hr/>	<hr/>	<hr/>
4.	<hr/>	<hr/>	<hr/>
5.	<hr/>	<hr/>	<hr/>
6.	<hr/>	<hr/>	<hr/>
7.	<hr/>	<hr/>	<hr/>
8.	<hr/>	<hr/>	<hr/>
9.	<hr/>	<hr/>	<hr/>
10.	<hr/>	<hr/>	<hr/>

## 16 Appendix C

### 16.1 Installation Checklist

Hospital:.....

ID No:.....

Sign:.....

#### 16.1.1 Shipping / Receiving

Check with heading chapter Installation.

- 1. Verify that the site is ready for installation.
- 2. Remove the crate's top and sides. Inspect for any shipping damage.
- 3. Inventory the shipment against the packing list, note any differences.

#### 16.1.2 Mechanical Installation

##### 16.1.2.1 Mechanical Installation of OTC

- 1. Ceiling rails Y.
- 2. Traverse rail X.
- 3. Y Brake.
- 4. Ceiling wagon.
- 5. Install safety clamp ring.
- 6. X Brakes.
- 7. Cable channel (Option).
- 8. Connection brake Y.
- 9. Wall attachment.

##### 16.1.2.2 Mechanical Installation of Cabinet

- 1. Cover for cable outlet.
- 2. Remove covers.

# Appendix C

## Installation Checklist

---

### 16.1.2.3 Mechanical Installation of Table 0181

- 1. Unload the Table.
- 2. Remove covers.
- 3. Safety clamp.
- 4. Orientation of the Table.
- 5. Insulation.
- 6. Adjust alignment.
- 7. Attachment to the floor.
- 8. Transport protection of the image receptor holder.
- 9. Adjust image receptor holder.

### 16.1.3 Electrical Installation

#### 16.1.3.1 Electrical Installation of Table 0181

- 1. Interfacing.
- 2. Connect the Table.
- 3. Mains power line connection.
- 4. Connect the mains power line.
- 5. Measure protective earth.

Measured value:

..... Ω  
..... Ω  
..... Ω  
..... Ω

#### 16.1.3.2 End Installation of Table 0181

- 6. Mount the table top.
- 7. Safety clamp.
- 8. Attach the covers.
- 9. Start up procedure  
*Check voltage of the Table.*

#### 16.1.3.3 Installation, Wallstand

- 1. Unload the Wallstand.
  - Orientation of the Wallstand.
  - Unload.
- 2. Mechanical installation of the Wallstand.
  - Fixation of the anchor.
  - Remove the back cover.
  - Mount the counterweights.

- 3. Mounting of parts.
  - Mount the image receptor.
  - Mount the patient support grip.
  - Install the foot control.
- 4. Electrical installation of the Wallstand.
  - Mains power line connection.
  - Connect Wallstand.
- 5. Measure protective earth.

Measured  
value:

..... Ω

..... Ω

### 16.1.3.4 Electrical Installation of Parts

- 1. Connect OTC.
- 2. Connect the Table.
- 3. Connect the Wallstand.
- 4. Connect the Image system.

### 16.1.3.5 Electrical Installation of X-ray light

- 1. Connect X-ray light.
- 2. Connect door switch.
- 3. Connect external emergency stop.

### 16.1.3.6 Electrical Installation of Operating Room

- 1. Operating room.
- 2. DAP display / printer.
- 3. Generator (option).

### 16.1.3.7 Voltage Selection

- 1. Power ratings and Line requirements.
- 2. Manual voltage selection.
- 3. Check protective earth.
- 4. Measure protective earth on cabinet.
- 5. Protective earth OTC.
- 6. Mains.
- 7. Start-up procedure.

### 16.1.4 Check Alignment of System

- 1. Alignment of the OTC.
- 2. Alignment of the OTC X- and Y-direction.

# Appendix C

## Installation Checklist

---

- 3. Alignment of the Wallstand.
- 4. Alignment of the Table.
- 5. Install the positioning index.

### 16.1.5 Calibration and Adjustments of Generator

- 1. Calibration process generator.
- 2. Communication setup.
- 3. Tube calibration  
Temperature of the X-ray tube  
Verify the function of the x-ray tube temperature (Sw) by loosen the cable (A), and check that the generator console displays the following message: "E020".  
Check the status of the tube, visual inspection. Ref. to the tube manual for further instruction.
- 4. Image receptor calibration.
- 5. Collimator light- and X-ray field alignment.  
If the System is cassette based and the detector is not present, check that you will get information on the image display.
- 6. Correspondence between x-ray field and image reception area.
- 7. APR-setup.
- 8. OTC calibration.
- 9. Ready exposure control signal.
- 10. Check that all exposure is inhibited when the detector is disconnected. See section; *Exposure Control*.
- 11. AEC calibration.
- 12. Generator backup.

### 16.1.6 Acceptance Tests

- 1. Peak tube potential.
- 2. Tube current.
- 3. Exposure time.
- 4. Linearity.
- 5. Beam quality.
- 6. Reproducibility.
- 7. DAP meter.
- 8. AEC (Automatic Exposure Control).
- 9. Emergency stops.
- 10. Check the SID calculation.

## Appendix C

### Installation Checklist

---

- 11. Verify the receptor indication light function on both Wallstand and Table according to Chapter 3 3.3.1.3 *Exposure Control*, Page 47.
- 12. Check the applicable exposure controls. See 3.3.1.3 *Exposure Control*, Page 47.
- 13. If applicable, check the detector ready signal.

# Appendix C

## Installation Checklist

---

### 16.1.7 Remark

No.	Remark	Action	Int note
1.	_____	_____	_____
2.	_____	_____	_____
3.	_____	_____	_____
4.	_____	_____	_____
5.	_____	_____	_____
6.	_____	_____	_____
7.	_____	_____	_____
8.	_____	_____	_____
9.	_____	_____	_____
10.	_____	_____	_____



## 17 Installation Report

### 17.1 Attention

The installation report is an important form for to receive feed-back from our dealers, in order to keep track of delivered systems and their current status. The report is required from all performed installations in order to comply with CFR 21 §1020.30.

The CE-mark to MDD Class II products is fulfilled through MDD ANNEX II 93/42/EEC where our Quality system is an essential part.

We kindly ask you to take the time needed to fulfil the report. The installation report form are delivered with each system (included in the Service and Installation Manual). There is also a digital form (this document) available which can be used.

Please send the fulfilled and signed report to [service@arcoma.se](mailto:service@arcoma.se). Sending the report confirms that you have installed the unit and that it is working properly on site.

If you encounter product related issues during the installation, it is important that we receive this information as input to our CAPA-process (Corrective and Preventive Action). For such reports please contact [service@arcoma.se](mailto:service@arcoma.se) (+46 470 70 69 70).

Best regards,

#### INFORMATION FROM THE DEALER

##### Product Identification

Equipment type: \_\_\_\_\_

System Serial number: \_\_\_\_\_

Date: \_\_\_\_\_

Dealer: \_\_\_\_\_

Installer: \_\_\_\_\_

##### Site Identification

Hospital/address: \_\_\_\_\_

Department: \_\_\_\_\_

Lab/room: \_\_\_\_\_

I hereby confirm that this installation is performed in accordance with the Installation chapter of Installation and Service Manual.

*Signature of Installer*

Date

Signature

\_\_\_\_\_

\_\_\_\_\_

**Canon**

CANON MEDICAL SYSTEMS USA, INC.